

Performance of A Standalone Solar Photovoltaic System

by Agus Jamal

Submission date: 30-Jul-2020 11:09AM (UTC+0700)

Submission ID: 1363878051

File name: Performance_of_A_Standalone_Solar_Photovoltaic_System.pdf (478.01K)

Word count: 3942

Character count: 22424

Performance of A Standalone Solar Photovoltaic System

1
Ramadoni Syahputra, Suko Ferbriyanto, Faaris Mujaahid, Agus Jamal, Sudarisman

Abstract: This paper presents a performance study on a standalone solar photovoltaic system. The application of photovoltaic solar cells is increasingly prevalent in Indonesia. Indonesia is a tropical country, where throughout the year, get sun exposure. This condition strongly supports the use of photovoltaic solar cells as a source of electrical energy. Many small to large-scale solar power generation systems have been built in Indonesia. On a small scale in the form of a standalone system, solar power plants are usually used as secondary power plants, where primary power plants still come from state electricity companies. In this research, the analysis of the performance of solar power plants for standalone systems with a capacity of 400 Wp. Efforts to improve the performance of solar cells are made by using a mirror reflector. The results showed that the mirror reflector could increase the output power of photovoltaic solar cells.

Index Terms: Renewable energy, solar photovoltaic, standalone system.

I. INTRODUCTION

Indonesia is located in a tropical region that is crossed by the equator [1]-[2]. This geographical position is very beneficial for Indonesia in terms of potential solar energy sources. All regions of Indonesia get sun exposure throughout the year, for 12 hours a day. Thus, solar energy is one of the sources of electrical energy, which is a priority in the development of renewable energy sources [3]-[7].

Solar power generation is one type of electrical energy generation that utilizes the emission from sunlight received by solar cells, which then form the sun's photon radiation is converted into electrical energy [8]. The performance of this solar power plant is strongly influenced by several factors, namely the PV module temperature factor, environmental weather conditions, environmental factors, and the intensity factor of sunlight [9]-[12]. These factors will significantly affect the electrical energy produced by the solar power plant. Solar cells that are used to capture the sun's rays will be

susceptible to the above factors so that the installation of solar cells is essential to see these factors. One square meter solar cell can produce 900 to 1000 watts of electricity by installing solar panels perpendicular to the sun, with the fact that solar cells are one of the most promising sources of energy [10]-[15].

II. LITERATURE REVIEW

Solar Photovoltaic System 5

Solar cells or photovoltaic cells are thin layers of pure silicon (Si) semiconductors and other semiconductor materials. This photovoltaic system converts electromagnetic energy from the sun into electrical energy [16]. Photovoltaics come from two words from the English language, "photo," and "volt," "Photo" means light and "Volt" is a unit of measurement of voltage in electricity. Solar cells are semiconductor devices with large surfaces consisting of "p" and "n" type diode circuits, with the ability to convert solar energy into electrical energy. The work of these solar cells is highly dependent on the photovoltaic effect to absorb solar energy and charge current to flow between two opposing layers [17]-[19].

Solar cells produce DC electrical energy, which will then be converted into AC electrical energy using an inverter if needed. Solar cells will always produce electricity as long as there is still sunlight even in cloudy conditions. The electrical energy that can be generated by a single solar cell is so small that it requires the combination of several solar panels into a component called a solar panel or solar module [20]. Therefore, by combining several solar cells into a component called a solar array, the benefit of this solar array is to increase the electrical energy of the solar panels [21].

Until now, many types of solar cells have been successfully developed by researchers. Generally, these types of solar cells are divided into three types, namely first-generation solar cells, second-generation solar cells, and third-generation solar cells, and the following is an explanation of the three types of solar cells [22]-[23].

a. First Generation

It is the earliest solar cell in production and until now. This first generation of production and installation still dominates with a 90% market share. First-generation solar cell material consists of silicon material, which is disproven into crystals with a high degree of purity, which is then called crystalline silicon. Crystalline silicon is divided into two types, monocrystalline and polycrystalline [24].

Solar cells with monocrystalline type can be seen from their physical appearance with a dull bluish color and without a pattern. This type has a high-efficiency value ranging from 16-17% even there are solar cells of this type, which have an efficiency of 20%. Based on physical form, this type has

1
Revised Manuscript Received on November 19, 2019.

Ramadoni Syahputra, Department of Electrical Engineering, Universitas Muhammadiyah Yogyakarta, Yogyakarta, Indonesia. E-mail: ramadoni@umy.ac.id.

Suko Ferbriyanto, Department of Electrical Engineering, Universitas Muhammadiyah Yogyakarta, Yogyakarta, Indonesia.

Faaris Mujaahid, Department of Electrical Engineering, Universitas Muhammadiyah Yogyakarta, Yogyakarta, Indonesia. E-mail: f.mujaahid@umy.ac.id.

Agus Jamal, Department of Electrical Engineering, Universitas Muhammadiyah Yogyakarta, Yogyakarta, Indonesia. E-mail: ajamal_me@gmail.com.

Sudarisman, Department of Mechanical Engineering, Universitas Muhammadiyah Yogyakarta, Yogyakarta, Indonesia. E-mail: sudarisman@umy.ac.id.

1
Retrieval Number: D9730118419/2019@BEIESP
DOI:10.35940/ijrte.D9730.118419

Performance of A Standalone Solar Photovoltaic System

smaller dimensions. However, of all these advantages, this type of solar cell has the disadvantage of being more expensive, given the complicated manufacturing process [25]-[26]. Also, this type of solar cell is not functioning correctly when it is cloudy weather, resulting in drastically reduced efficiency. Figure 1 shows the monocrystalline type solar panel while Figure 2 shows the polycrystalline type solar panel [27].



Figure 1. Monocrystalline type solar panel

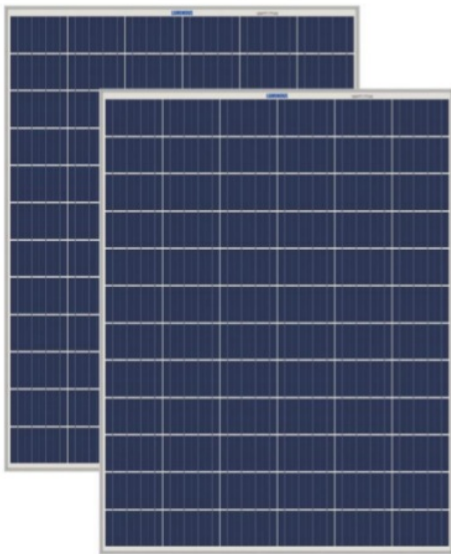

Figure 2. Polycrystalline type solar panel

b. Second generation

Second Generation This solar cell has a thickness that is much thinner than the first generation with a size of only a few microns. This thin layer solar cell is made of a-Si (silicon amorphous) material, CdTe (cadmium telluride), and CIGS (Copper Indium Gallium Selenide). Silicon amorphous is silicon that is simpler than crystalline silicon. CdTe and CIGS are semiconductor alternative materials that can convert photon energy to sunlight. This second-generation solar cell only has a 9% market share [28].

The advantage of this second-generation solar cell lies in the more straightforward manufacturing process and lower production costs. However, these solar cells have fundamental shortcomings, such as a low level of efficiency,

because only around 6-8%, which is a rare and poisonous material. So that solar cells of this type are not suitable for use as power plants. However, it is more suitable for applications that do not require significant, inexpensive energy such as calculators and watches.

c. Third Generation

This third-generation is the last generation of solar cells, but until now, the status is still being tested. The researchers developed this third-generation solar cell with the hope of combining better solar cell performance in terms of efficiency and easy manufacturing process. So that this third-generation solar panel will have better quality than the first generation, and the production costs are cheaper than the second generation [28]-[29]. Besides having advantages over the previous two generations, this third-generation also offers thinner solar cell technology because it belongs to the thin-film category [30]-[32]. This third-generation solar cell has three types that have been developed so far, namely Perovskite, DSCC, and OPV. Perovskite has the function of an electrolyte to absorb sunlight, and then it will excite positive charges (holes) and negative charges (electrons). Electrons will go to Electron Transport Material and act as n-type semiconductors, the efficiency of this type of perovskite reaches 20.2%. Organic solar cells are made from organic semiconductor materials such as polyphenylene vinylene and fullerene. Dye-sensitized solar cells are made by coating dyes intended to increase the efficiency of sunlight conversion. Figure 3 shows the amorphous solar cell.



Figure 3. Amorphous solar cell

Installation of Solar Photovoltaic System

The installation of a wiring system in a solar cell consists of two systems, namely a system using a series circuit and a system that uses a parallel circuit.

- a. Solar cells using a series circuit
In the series of circuits found in the solar cell, the first solar cell positive pole (+) must be connected to the negative pole of the other solar panels and so on.
- b. Solar cells using parallel circuits

1

Retrieval Number: D9730118419/2019@BEIESP
DOI:10.35940/ijrte.D9730.118419

In solar cells that use parallel circuits, positive polar (+) solar cells are connected to positive polar (+) solar cells, as well as negative polar (-) solar cells must also be connected to negative polar (-) other solar cells. Figure 4 shows the PV arrays arranged in parallel series.

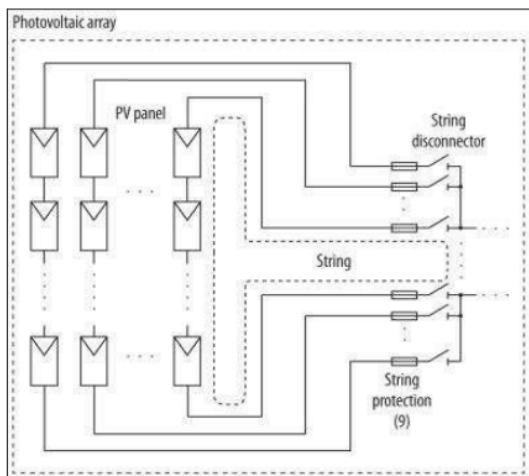

Figure 4. PV arrays arranged in parallel series

Some solar modules (a combination of several solar cells) are arranged in series to increase the voltage to match the input specifications of the charge controller/inverter. The series of solar modules arranged in series is called a PV string.

Parallel PV string aims to increase power according to the capacity to be installed. Before entering into the charge controller, the solar module will be protected first in a panel, which is generally called a combiner box. There is a fuse that protects each sting, surge arresters to protect from lightning, MCCB, and some literature using blocking diodes.

III. METHODOLOGY

The implementation of this research took place at the batik home industry in Yogyakarta, Indonesia. This batik production activity starts at 08.00 WIB until 16.00 WIB. Ten workers carry out batik production activities in this batik home industry. Five workers did the batik tasting process, three workers did the production of written batik, and two workers did the process of coloring and releasing wax.

The batik production process is also in dire need of electricity supply to support the batik production process. The batik production process is also in dire need of electricity supply to support the batik production process. So this is where the utilization of energy sources from solar panels is needed. Electrical energy is used to turn on lights and water pumps. Lights are needed when batik production is cloudy so that the accuracy of the tasting and inclusion process still produces excellent results. Also, during the coloring process and lighting, the lights are always turned on while the water pump is used to meet the needs of water in the process of removing wax and coloring and afterward washing of batik cloth so that the supply of electrical energy is necessary during the production of this batik.

In this research, we will see the efficiency produced by solar panels in the batik industry. Next, the reflector will be installed on the solar panel that has been installed. The steps of this study was shown in Figure 5.

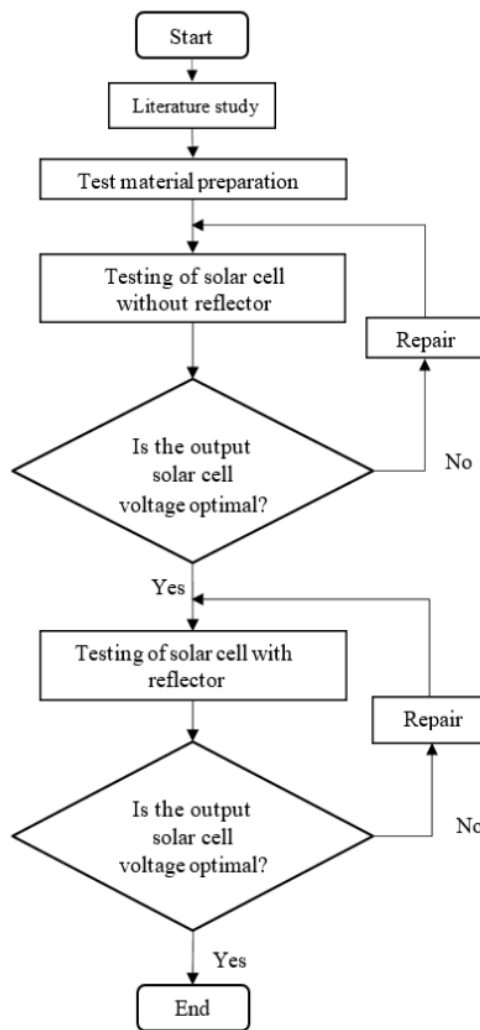

Figure 5. The steps of this study

IV. RESULTS AND DISCUSSION

Research Object Condition Data

The object of this research is a solar power plant located in the batik industry of Yogyakarta, Indonesia. The solar power plant in the batik industry is an off-grid type, with a total capacity of 800 Wp. The primary utilization in the batik industry is to supply electricity needs in the batik production area, namely for lighting, electric batik stoves, and water pumps. The location of the batik industry is in Bergam hamlet, Wijirejo village, Pandak sub-district, Bantul District, Yogyakarta Special Province,

Performance of A Standalone Solar Photovoltaic System

Indonesia, as shown in Figure 6.

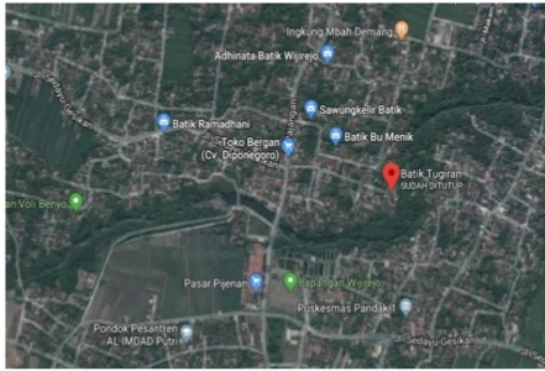

Figure 6. Location map of the batik industry is in Bergang hamlet, Wijirejo village, Pandak sub-district, Bantul District, Yogyakarta Special Province, Indonesia

Testing of Solar Photovoltaic System

In this study, it is testing the use of a reflector from a different material with a fixed angle of 70° , as can be seen in Figure 7. The degree of tilt obtained from the results of previous studies, which states that at an angle of 70° , produces the output of the most maximum solar panels. The work of the reflector is to reflect sunlight radiation so that more sunlight is received by the solar panels. The thing that influences this research is the intensity of solar radiation every day, which is influenced by the weather.



Figure 7. Solar photovoltaic system with reflector

In the solar power plant in the batik industry, there are two groups of solar panels used; the first is five solar panels with a capacity of 400 Wp. The second group contained four solar panels with a capacity of 400 Wp. This research only focuses on the second group solar panel with a capacity of 400 Wp. The series of 4 solar panels themselves are arranged in parallel.

Data on solar radiation irradiation at the location of solar power plants in the batik industry was obtained through a website from NASA, by entering the latitude and longitude

coordinates of an area on the website via the internet online. After that, the data that will be sought is the sun's radiation data for the area in one day. Daily radiation data obtained an average of $10.25 \text{ kW-hr / m}^2/\text{d}$. Figure 8 shows the daily radiation in the location of batik industry.

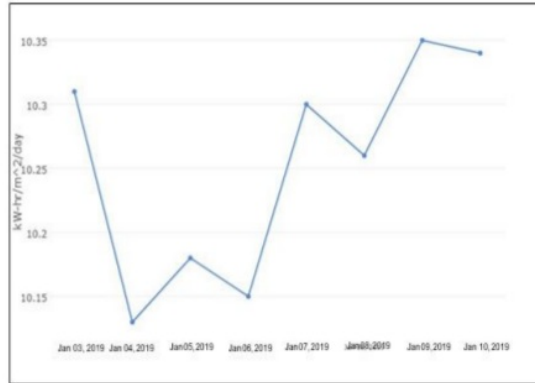

Figure 8. Daily radiation in the location of batik industry

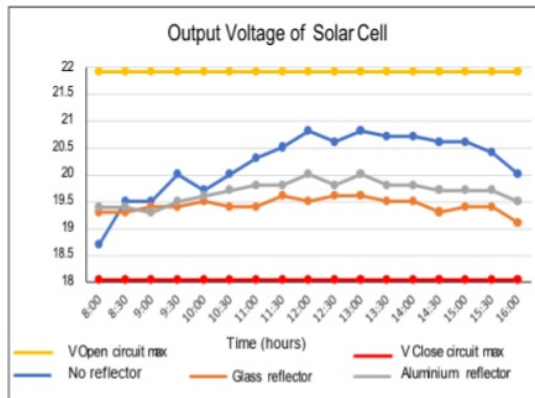

Figure 9. Output voltage of solar photovoltaic system in batik industry

Figure 9 shows the output voltage of solar photovoltaic system in batik industry. The measured voltage in this study is the open-circuit voltage (V_{OC}). Viewed from the graph in Figure 9, solar panels that do not use reflectors produce the highest output voltage. Whereas when a reflector using a glass reflector produces the lowest output voltage. However, the voltage difference between the three conditions is not too significant with the vulnerable voltage of the solar panel output there is $18.7 \text{ V} - 20.8 \text{ V}$. This performance shows that the value of the open-circuit voltage is still below the specifications of the solar panel that is equal to 21.9 V . This performance is due to solar radiation not only photon radiation but also thermal radiation. This increase in surface temperature will result in a decrease in the output voltage of the solar panels. Solar panels with the addition of glass reflectors have the highest average power increase of 0.949 watts .

1

Retrieval Number: D9730118419/2019@BEIESP
DOI:10.35940/ijrte.D9730.118419

V. CONCLUSION

Based on the analysis of the effect of the use of reflectors on solar power generation systems in the batik industry that has been done, it can be concluded that the addition of reflectors on solar panels will also cause an increase in the surface temperature of solar panels. This fact is due to solar radiation not only photon radiation but also thermal radiation. This increase in surface temperature will result in a decrease in the output voltage of the solar panels. Solar panels with the addition of glass reflectors have the highest average power increase of 0.949 watts.

ACKNOWLEDGMENTS

We would like to acknowledge to the Directorate of Research and Community Service (DRPM), Directorate General of Development and Research Enhancement, Ministry of Research, Technology, and Higher Education of the Republic of Indonesia, for the contributions of funding this research.

REFERENCES

1. Soedibyo, Ashari, M., Syahputra, R. (2014). "Power loss reduction strategy of distribution network with distributed generator integration", Proceeding of 2014 1st International Conference on Information Technology, Computer, and Electrical Engineering (ICTACEE) 2014, UNDIP Semarang, pp. 404 - 408.
2. Jamal, A., Suropto, S., Syahputra, R. (2015). Multi-Band Power System Stabilizer Model for Power Flow Optimization in Order to Improve Power System Stability. Journal of Theoretical and Applied Information Technology (JATIT), 80(1), pp. 116-123.
3. Syahputra, R., Soesanti, I. (2015). Power System Stabilizer model based on Fuzzy-PSO for improving power system stability. 2015 International Conference on Advanced Mechatronics, Intelligent Manufacture, and Industrial Automation (ICAMIMIA), Surabaya, 4-17 Oct. 2015 pp. 121 - 126.
4. Syahputra, R., Robandi, I., Ashari, M. (2014). Optimization of Distribution Network Configuration with Integration of Distributed Energy Resources Using Extended Fuzzy Multi-objective Method. International Review of Electrical Engineering (IREE), 9(3), pp. 629-639.
5. Syahputra, R., Robandi, I., Ashari, M., (2012), "Reconfiguration of Distribution Network with DG Using Fuzzy Multi-objective Method", International Conference on Innovation, Management and Technology Search (ICIMTR), May 21-22, 2012, Melacca, Malaysia.
6. Soesanti, I., Syahputra, R. (2016). Batik Production Process Optimization Using Particle Swarm Optimization Method. Journal of Theoretical and Applied Information Technology (JATIT), 86(2), pp. 272-278.
7. Syahputra, R., Robandi, I., Ashari, M. (2015). PSO Based Multi-objective Optimization for Reconfiguration of Radial Distribution Network. International Journal of Applied Engineering Research (IJAER), 10(6), pp. 14573-14586.
8. J. Ahmed, Z. Salam. (2018), "An Enhanced Adaptive P&O MPPT for Fast and Efficient Tracking Under Varying Environmental Conditions", IEEE Transactions on Sustainable Energy, Vol. 9, No. 3, pp. 1487 - 1496.
9. Jiang, R., Han, Y., Zhang, S. (2017). Wide-range, high-precision and low-complexity MPPT circuit based on perturb and observe algorithm. Electronics Letters, 53(16), pp. 1141 - 1142.
10. Peng, B.R., Che, K., Liu, Y.H. (2018). A Novel and Fast MPPT Method Suitable for Both Fast Changing and Partially Shaded Conditions, IEEE Transactions on Industrial Electronics, 65(4), pp. 3240 - 3251.
11. Hossain, M.K., Ali, M.H. (2013). Overview on Maximum Power Point Tracking (MPPT) Techniques for Photovoltaic Power Systems.

12. International Review of Electrical Engineering (IREE), 8(4), pp. 1363-1378.
13. Brusco, G., A. Burgio, D. Menniti, A. Pinnarelli, N. Sorrentino. (2014). Optimal Sizing of DGs for a CHP-Based Agro-Industrial Microgrid with a Priority Criteria Operational Strategy, International Review of Electrical Engineering (IREE), 9(2), pp. 351-362.
14. Syahputra, R., Soesanti, I. (2017). Modeling of Wind Power Plant with Doubly-Fed Induction Generator. Jurnal Teknologi, Journal of Electrical Technology UMY (JET-UMY), 1(3), pp. 126-134.
15. Syahputra, R., Soesanti, I. (2016). DFIG Control Scheme of Wind Power Using ANFIS Method in Electrical Power Grid System. International Journal of Applied Engineering Research (IJAER), 11(7), pp. 5256-5262.
16. Syahputra, R., Wiyagi, R.O., Sudarisman. (2017). Performance Analysis of a Wind Turbine with Permanent Magnet Synchronous Generator. Journal of Theoretical and Applied Information Technology (JATIT), 95(9), pp. 1950-1957.
17. Syahputra, R., Soesanti, I., Ashari, M. (2016). Performance Enhancement of Distribution Network with DG Integration Using Modified PSO Algorithm. Journal of Electrical Systems (JES), 12(1), pp. 1-19.
18. Syahputra, R., Robandi, I., Ashari, M. (2015). Performance Improvement of Radial Distribution Network with Distributed Generation Integration Using Extended Particle Swarm Optimization Algorithm. International Review of Electrical Engineering (IREE), 10(2), pp. 293-304.
19. Syahputra, R. (2017). Distribution Network Optimization Based on Genetic Algorithm. Jurnal Teknologi, Journal of Electrical Technology UMY (JET-UMY), 1(1), pp. 1-9.
20. Mujaahid, F., Fauzi, A.M., Syahputra, R., Putra, K.T., Purwanto, K. Potentials of Organic Waste Conversion in a Green Campus Concept. Journal of Electrical Technology UMY (JET-UMY), 1(4), pp. 183-188.
21. Ahmed, J., Salam, Z. (2018). An Enhanced Adaptive P&O MPPT for Fast and Efficient Tracking Under Varying Environmental Conditions, IEEE Transactions on Sustainable Energy, 9(3), pp. 1487 - 1496.
22. Hui, J.C.y., Bakhshai, A., Jain, P.K. (2016). An Energy Management Scheme With Power Limit Capability and an Adaptive Maximum Power Point Tracking for Small Standalone PMSG Wind Energy Systems, IEEE Transactions on Power Electronics, 31(7), pp. 4861 - 4875.
23. Hui, J.C.y., Bakhshai, A., Jain, P.K. (2015). A Sensorless Adaptive Maximum Power Point Extraction Method With Voltage Feedback Control for Small Wind Turbines in Off-Grid Applications, IEEE Journal of Emerging and Selected Topics in Power Electronics, 3(3), pp. 817 - 828.
24. Tang, L., Xu, W., Mu, C. (2017). Analysis for step-size optimisation on MPPT algorithm for photovoltaic systems, IET Power Electronics, 10(13), pp. 1647 - 1654.
25. Ghasemi, M.A., Ramyar, A., Eini, H.I. (2018). MPPT Method for PV Systems Under Partially Shaded Conditions by Approximating I-V Curve, IEEE Transactions on Industrial Electronics, 65(5), pp. 3966 - 3975.
26. Farhat, S., Alaoui, R., Kahaji, A., Bouhouch, L., Ihlal, A. (2015). P&O and Incremental Conductance MPPT Implementation. International Review of Electrical Engineering (IREE), 10(1), pp. 116-122.
27. Metry, M., Shadmand, M.B., Balog, R.S., Abu-Rub, H. (2017). MPPT of Photovoltaic Systems Using Sensorless Current-Based Model Predictive Control, IEEE Transactions on Industry Applications, 53(2), pp. 1157 - 1167.
28. Jamal, A., Syahputra, R. (2016). Heat Exchanger Control Based on Artificial Intelligence Approach. International Journal of Applied Engineering Research (IJAER), 11(16), pp. 9063-9069.
29. Kebede, M.H., Beyene, G.B. (2018). Feasibility Study of PV-Wind-Fuel Cell Hybrid Power System for Electrification of a Rural Village in Ethiopia. Journal of Electrical and Computer Engineering, 2018.
30. Syahputra, R., Soesanti, I. (2016). Application of Green Energy for Batik Production Process. Journal of Theoretical and Applied Information Technology (JATIT), 91(2), pp. 249-256.
31. L. Tang, W. Xu, C. Mu, "Analysis for step-size optimisation on MPPT algorithm for photovoltaic systems", IET Power Electronics, Vol. 10, No. 13, pp. 1647 - 1654, 2017.
32. Sher, H.A., Addoweesh, K.E., Al-Haddad, K. (2018). An Efficient and Cost-Effective Hybrid MPPT Method for a Photovoltaic Flyback

Performance of A Standalone Solar Photovoltaic System

Microinverter, IEEE Transactions on Sustainable Energy, 9(3), pp. 1137 - 1144.

32. Syahputra, R., Soesanti, I. (2016). An Optimal Tuning of PSS Using AIS Algorithm for Damping Oscillation of Multi-machine Power System. Journal of Theoretical and Applied Information Technology (JAITT), 94(2), pp. 312-326.

1

AUTHORS PROFILE



Ramadoni Syahputra received B.Sc. degree from Institut Teknologi Medan in 1998, M.Eng. degree from Department of Electrical Engineering, Universitas Gadjah Mada, Yogyakarta, Indonesia in 2002, and Ph.D degree at the Department of Electrical Engineering, Faculty of Industrial Technology, Institut Teknologi Sepuluh Nopember, Surabaya, Indonesia. His research interests are in power system optimization, power system control, AI in power system, optimization, and renewable energy.



Suko Ferbriyanto received B.Sc. degree from Department of Electrical Engineering, Universitas Muhammadiyah Yogyakarta, Yogyakarta, Indonesia in 2019. His research interests are in operation of power system and renewable energy systems.



Faaris Mujaahid hold a bachelor degree in 2010 from Electrical and Electronics Engineering Department, Saxion University of Applied Sciences, the Netherlands. He received a master degree in Sustainable Energy Technologies in 2016 from University of Southampton, UK. ing. Faaris Mujaahid, M.Sc is currently a lecturer in the Department of Electrical Engineering, Faculty of Engineering, Universitas Muhammadiyah Yogyakarta, Indonesia. His main research interest is in LabVIEW and renewable energy (mainly in solar cell material and fabrication technologies).



Agus Jamal is a lecturer and researcher in Electrical Engineering Department, Faculty of Engineering, Universitas Muhammadiyah Yogyakarta (UMY). He received bachelor degree and M.Eng degree from Universitas Gadjah Mada (UGM), in 1994 and 2010, respectively. His research interests are in electrical machinery, harmonics, power system quality, and high rise building.



Sudarisman is a lecturer and researcher in Mechanical Engineering Department, Faculty of Engineering, Universitas Muhammadiyah Yogyakarta (UMY). He received bachelor degree from IKIP Yogyakarta in 1983, M.Sc degree from Michigan State University (College of Engineering) in 1995, and Ph.D. degree from Curtin University of Technology. His research interests are in material engineering, electrochemical machining, composite, fiber-epoxy system, and renewable energy.

1

Retrieval Number: D9730118419/2019@BEIESP
DOI:10.35940/ijrte.D9730.118419

Performance of A Standalone Solar Photovoltaic System

ORIGINALITY REPORT

32%

SIMILARITY INDEX

%

INTERNET SOURCES

32%

PUBLICATIONS

%

STUDENT PAPERS

PRIMARY SOURCES

- 1 "Reliability Index of Wind-Solar Hybrid Power Plants using the Expected Energy Not Supplied Method", International Journal of Recent Technology and Engineering, 2019 27%
Publication
- 2 Agus Jamal, Sekarlita Gusfat, Anna Nur, Ramadoni Syahputra. "Power Quality Evaluation for Electrical Installation of Hospital Building", International Journal of Advanced Computer Science and Applications, 2019 1%
Publication
- 3 F Mujaahid, S Febriyanto, R Syahputra, K Purwanto. "Impact of the solar energy system with and without reflector on home-scale batik industry", Journal of Physics: Conference Series, 2020 1%
Publication
- 4 Ramadoni Syahputra, Indah Soesanti. "An artificial immune system algorithm approach for reconfiguring distribution network", AIP Publishing, 2017 1%

5 Mohammad Irfan Fahmi, Hidayatullah, JhonsonEfendi Hutagalung, Sajadin Sembiring. "Electrical Automation of Solar Cell-Based Arduino Uno With 16 × LCD Display", Emerald, 2018 **1%**
Publication

6 "An Efficient Shunt Active Filter for Harmonic Reduction in Hospital Building Electrical Installation", International Journal of Recent Technology and Engineering, 2019 **1%**
Publication

Exclude quotes On
Exclude bibliography Off

Exclude matches < 1%