

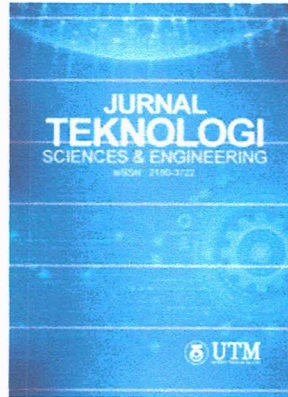

## Jurnal Teknologi



### SCOPE OF PUBLICATION

Jurnal Teknologi welcomes quality research in the area of Mathematics, Natural Sciences (Biological Sciences, Physical Sciences: Physics, Chemistry, Astronomy, Earth Science) and Applied Mathematics and Natural Sciences (Building Physics, Mechanical Engineering, Chemical Engineering, Civil Engineering, Material Science, Biochemistry, Medical Engineering).

**Indexed by: SCOPUS, ESCI-WOS, ACI, MYCITE, MYJURNAL**

### HISTORY OF JURNAL TEKNOLOGI

Jurnal Teknologi was first published in April 1977, then known as Teknologgi. Its publications, however, only began to take off on regular basis in 1992.

The publication of Jurnal Teknologi aims to be the forum for academics and practitioners to write and publish their latest work. Specifically, the journal serves to disseminate to the public results of current and on-going research projects conducted by UTM academics in various fields.

As the journal continues to grow, starting from June 1999, with volume No. 30, Jurnal Teknologi was revamped. The journal now comes in a set of six series (A – F), published twice a year (June and December). Each series specifically focuses on specialized fields: A (Manufacturing, Advanced Materials, Energy, and Transport); B (Construction, Design, and Planning); C (Science and Mathematics); D (Electronics, Control, Communication, and Information Technology); E (Management, Education, and Social Sciences) and F (Environment and Process Technology).

Starting from year 2010, six series of Jurnal Teknologi were merged into two series known as; Jurnal Teknologi (Science and Engineering) and Jurnal Teknologi (Social Sciences). Published online six time a year (January, March, May, July, September and November). On 2016, Jurnal Teknologi (Sciences and Engineering) will be published every month. However, under new management, Jurnal Teknologi (Science and Engineering) will be published online six time a year (January, March, May, July, September and November) on 2017.

On 2014, Jurnal Teknologi (Sciences & Engineering) has been separated from Jurnal Teknologi (Social Sciences). Jurnal Teknologi (Social Sciences) is now known as Sains Humanika.

Jurnal Teknologi (Sciences & Engineering) is now indexed by **SCOPUS**.

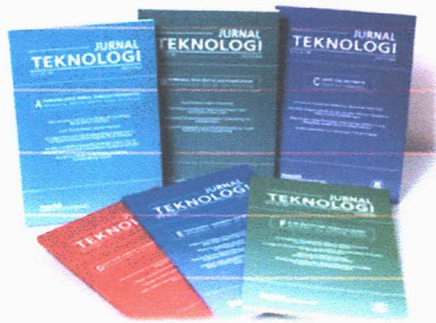

---

## Announcements

---

### Research Article Format

Dear authors, we would love to see your Research Articles written in Jurnal Teknologi's format :

- 1.0 INTRODUCTION**
- 2.0 METHODOLOGY**
- 3.0 RESULTS AND DISCUSSION**
- 4.0 CONCLUSION**
- Acknowledgement**

This will help us and our audience have a better understanding what your article is all about.

Thank you. Your cooperation is deeply appreciated.

*Posted: 2018-09-13*

### How to reach us for any inquiries

For any inquiries or questions, please contact us by email to [journal\\_utm@utm.my](mailto:journal_utm@utm.my) or [qpenerbit@utm.my](mailto:qpenerbit@utm.my). We will try our best to help you.

Thank you.

### **UTM eJournal Editorial Team**

Penerbit UTM Press  
Universiti Teknologi Malaysia

*Posted: 2017-11-30*

### Sains Humanika

Jurnal Teknologi (Social Sciences) has been rebranded into Sains Humanika. To submit your article, kindly visit our portal: <https://sainshumanika.utm.my>

*Posted: 2014-05-20*

---

[More Announcements...](#)

## Vol 82, No 2: Forthcoming Issue: March 2020

Expected date of publication: February 2020

### Table of Contents

#### Science and Engineering

[PERFORMANCE FEATURES OF THE SUNFLOWER SEEDS OIL AS A HYDRAULIC BIO FLUID UNDER VARIOUS NORMAL LOADS](#)

Mohammed Hassan Jabal, Muhannad Zedan Khlefia, Israa S. Ahmed, Hind Dawood Salman

Home > About the Journal > **Editorial Team**

## Editorial Team

### Chief Editor

[Professor Dr. Rosli Md Illias](#), Universiti Teknologi Malaysia, Malaysia

### Editors

[Professor Datuk Dr. Ahmad Fauzi Ismail](#), Universiti Teknologi Malaysia, Malaysia

[Professor Dr. Muhammad Hisyam Lee](#), Universiti Teknologi Malaysia, Malaysia

[Professor Dr. Ruzairi Abdul Rahim](#), Universiti Teknologi Malaysia, Malaysia

[Professor Dr. Azman Hassan](#), Universiti Teknologi Malaysia, Malaysia

[Professor Dr. Hadi Nur](#), Universiti Teknologi Malaysia, Malaysia

[Professor Dr. Mohammad Nazri Mohd. Jaafar](#), Universiti Teknologi Malaysia, Malaysia

[Professor Dr. Zainal Salam](#), Universiti Teknologi Malaysia, Malaysia

[Professor Dr. Rosli Hussin](#), Universiti Teknologi Malaysia, Malaysia

[Professor Dr. Mohd. Rosli Hainin](#), Universiti Teknologi Malaysia, Malaysia

[Professor Dr. Mohd Shahir Shamsir Omar](#), Universiti Teknologi Malaysia, Malaysia

[Professor Dr. Safian Sharif](#), Universiti Teknologi Malaysia, Malaysia

[Professor Sr. Dr. Mazlan Hashim](#), Universiti Teknologi Malaysia, Malaysia

[Professor Dr. Mohd Saberi Mohamad](#), Universiti Malaysia Kelantan, Malaysia

[Professor Dr. Hesham Ali El-Enshasy](#), Universiti Teknologi Malaysia, Malaysia

[Assoc. Prof. Dr. Norhazilan Md Noor](#), Universiti Teknologi Malaysia, Malaysia

[Assoc. Prof. Dr. Mohd Hafiz Dzarfan Othman](#), Universiti Teknologi Malaysia, Malaysia

[Dr. Pei Sean Goh](#), Universiti Teknologi Malaysia, Malaysia

[Dr. Syafiqah Saidin](#), Universiti Teknologi Malaysia, Malaysia

[Dr. Dalila Mat Said](#), Universiti Teknologi Malaysia, Malaysia

### Editorial Board

[Professor I. S. Jawahir](#), University of Kentucky, United States

[Professor Dr. Xianshe Feng](#), University of Waterloo, Canada

[Professor Dr. Mustafizur Rahman](#), National University of Singapore, Singapore

[Professor Dr. William McClusky](#), University of Ulster, United Kingdom

[Professor Vijay K. Arora](#), Wilkes University, United States

[Assoc. Prof. Dr. G. Arthanareeswaran](#), National Institute of Technology, Tiruchirapalli, INDIA

[Assoc. Professor Dr. Arun M Isloor](#), National Institute of Technology Karnataka, INDIA

[Professor Dr. Jamaliah Md Jahim](#), Universiti Kebangsaan Malaysia, Malaysia

[Professor Dr. Che Hassan Che Haron](#), Universiti Kebangsaan Malaysia, Malaysia



Copyright © 2012 Penerbit UTM Press, Universiti Teknologi Malaysia.

Disclaimer : This website has been updated to the best of our knowledge to be accurate. However, Universiti Teknologi Malaysia shall not be liable for any loss or damage caused by the usage of any information obtained from this web site.

Best viewed: Mozilla Firefox 4.0 & Google Chrome at 1024 × 768 resolution.





Home > Archives > **Vol 80, No 1**

## Vol 80, No 1

January 2018

### Table of Contents

#### Science and Engineering

<a href="#">DISINTEGRATION AND SOLUBILISATION OF ACTIVATED SLUDGE FROM RUBBER PROCESSING INDUSTRY BY OZONATION</a>	<a href="#">PDF</a>
Siti Fatimah Zahra Mohd Sarif, Syifa' Syahida Alias, Fahmi Muhammad Ridwan, Che Zulzikrami Azner Abidin, Umi Fazara Md. Ali, Ku Sahrom Ku Salim	
<a href="#">RADIATION PATTERN RECONFIGURABLE MICROSTRIP PATCH ANTENNA USING DUAL DELAY LINE</a>	<a href="#">PDF</a>
M. A. Aris, M. T. Ali, N. H. Ab Rahman, I. Pasya	
<a href="#">SPATIAL AND TEMPORAL BEHAVIOR OF PB, CD, AND ZN RELEASE DURING SHORT TERM LOW INTENSITY RESUSPENSION EVENTS</a>	<a href="#">PDF</a>
M. T. Mahamod, W. H. M. Wan Mohtar, S. F. M. Yusoff	
<a href="#">IMPROVING STABILITY OF CHLOROPHYLL AS NATURAL DYE FOR DYE-SENSITIZED SOLAR CELLS</a>	<a href="#">PDF</a>
Zainal Arifin, Sudjito Soeparman, Denny Widhiyanuriawan, Suyitno Suyitno, Argatya Tara Setyaji	
<a href="#">IN-VITRO BIOCOMPATIBILITY STUDY OF HYDROXYAPATITE COATED ON CO-CR-MO WITH OXIDE INTERLAYER</a>	<a href="#">PDF</a>
H. Mas Ayu, S. Izman, R. Daud, A. Shah, Mahmood Anwar, G. Krishnamurthy, T. Kamarul	
<a href="#">A SINGLE-VENDOR SINGLE-BUYER INTEGRATED PRODUCTION-INVENTORY MODEL WITH QUALITY IMPROVEMENT AND CONTROLLABLE PRODUCTION RATE</a>	<a href="#">PDF</a>
Wakhid Ahmad Jauhari	
<a href="#">THE INTER-RATER AND INTRA-RATER RELIABILITY ANALYSIS OF WORKPLACE ERGONOMIC RISK ASSESSMENT</a>	<a href="#">PDF</a>
Jafri Mohd. Rohani, Ademola James Adeyemi, Roseni Abd. Aziz, Mat Rebi Abdul Rani	
<a href="#">INPUT SHAPING TECHNIQUES FOR SWAY CONTROL OF A ROTARY CRANE SYSTEM</a>	<a href="#">PDF</a>
Ahmad Alhassan, Z. Mohamed, Auwalu M. Abdullahi, Amir A. Bature, Ado Haruna, Nura M. Tahir	
<a href="#">PREDICTING THE RHEOLOGICAL PROPERTIES OF BITUMEN-FILLER MASTIC USING ARTIFICIAL NEURAL NETWORK METHODS</a>	<a href="#">PDF</a>
Nursyahirah Khamis, Muhamad Razuhanafi Mat Yazid, Asmah Hamim, <b>Sri Atmaja P. Rosyidi</b> , Nur Izzi Md. Yusoff, Muhamad Nazri Borhan	
<a href="#">THE USE OF MIXED WASTE RECYCLED PLASTIC AND GLASS AS AN AGGREGATE REPLACEMENT IN ASPHALT MIXTURES</a>	<a href="#">PDF</a>
Nur Mustakiza Zakaria, Mohammad Kamal Hassan, Ahmad Nazrul Hakimi Ibrahim, Sri Atmaja P. Rosyidi, Nur Izzi Md. Yusoff, Abdullahi Ali Mohamed, Norhidayah Hassan	
<a href="#">SEISMIC PERFORMANCE OF SCALED IBS BLOCK COLUMN FOR STATIC NONLINEAR MONOTONIC PUSHOVER EXPERIMENTAL ANALYSIS</a>	<a href="#">PDF</a>
Chun-Chieh Yip, Abdul Kadir Marsono, Jing-Ying Wong, Shu-Chi Lee	
<a href="#">IMPROVEMENT OF BIOGAS UPGRADING PROCESS USING CHEMICAL ABSORPTION AT AMBIENT CONDITIONS</a>	<a href="#">PDF</a>
Fouad R. H. Abdeen, Maizirwan Mel, Mohammed Saedi Jami, Sany Izan Ihsan, Ahmad Faris Ismail	
<a href="#">INVESTIGATING THE INFLUENCE OF STEEL SURFACE ROUGHNESS AND MULTIPLE CFRP LAYERS ON THE BONDING BEHAVIOUR OF A SINGLE-STRAP JOINT</a>	<a href="#">PDF</a>
Ahmed W. Al-Zand, Wan Hamidon Wan Badruzzaman	
<a href="#">APIGENIN INCREASES CISPLATIN INHIBITORY EFFECTS ON THE TELOMERASE ACTIVITY OF TRIPLE NEGATIVE BREAST CANCER CELLS</a>	<a href="#">PDF</a>

# PREDICTING THE RHEOLOGICAL PROPERTIES OF BITUMEN-FILLER MASTIC USING ARTIFICIAL NEURAL NETWORK METHODS

Nursyahirah Khamis<sup>a</sup>, Muhamad Razuhanafi Mat Yazid<sup>a\*</sup>, Asmah Hamim<sup>a</sup>, Sri Atmaja P. Rosyidi<sup>b</sup>, Nur Izzī Md. Yusoff<sup>a</sup>, Muhamad Nazri Borhan<sup>a</sup>

<sup>a</sup>Department of Civil & Structural Engineering, Faculty of Engineering & Built Environment, Universiti Kebangsaan Malaysia, 43600, Bangi, Selangor, Malaysia

<sup>b</sup>Department of Civil Engineering, Universitas Muhammadiyah Yogyakarta, Indonesia

## Article history

Received

23 May 2017

Received in revised form

24 July 2017

Accepted

1 November 2017

\*Corresponding author  
razuhanafi@ukm.edu.my

## Graphical abstract

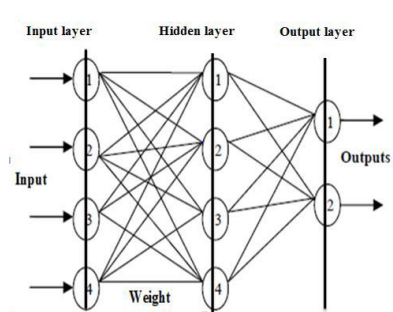

## Abstract

This study was conducted to develop two types of artificial neural network (ANN) model to predict the rheological properties of bitumen-filler mastic in terms of the complex modulus and phase angle. Two types of ANN models were developed namely; (i) a multilayer feed-forward neural network model and (ii) a radial basis function network model. This study was also conducted to evaluate the accuracy of both types of models in predicting the rheological properties of bitumen-filler mastics by means of statistical parameters such as the coefficient of determination ( $R^2$ ), mean absolute error (MAE), mean squared error (MSE) and root mean squared error (RMSE) for every developed model. A set of dynamic shear rheometer (DSR) test data was used on a range of the bitumen-filler mastics with three filler types (limestone, cement and grit stone) and two filler concentrations (35 and 65% by mass). Based on the analysis performed, it was found that both models were able to predict the complex modulus and phase angle of bitumen-filler mastics with the average  $R^2$  value exceeding 0.98. A comparison between the two types of models showed that the radial basis function network model has a higher accuracy than multilayer feed-forward neural network model with a higher value of  $R^2$  and lower value of MAE, MSE and RMSE. It can be concluded that the ANN model can be used as an alternative method to predict the rheological properties of bitumen-filler mastic.

**Keywords:** Artificial neural network, multilayer feed-forward neural network, radial basis function network, complex modulus ( $G^*$ ) and phase angle ( $\delta$ )

## Abstrak

Kajian ini dijalankan untuk membangunkan dua jenis peramalan model berdasarkan pendekatan rangkaian neuron tiruan (ANN) untuk meramalkan sifat-sifat reologi mastik-pengisi bitumen dari segi modulus dan sudut fasa yang kompleks. Dua jenis model ANN telah dibangunkan iaitu; (i) suatu model rangkaian neural galakan ke hadapan pelbagai lapisan dan (ii) model rangkaian fungsi asas jejarian. Kajian ini juga dijalankan untuk menilai ketepatan kedua-dua jenis model untuk meramalkan sifat-sifat reologi mastik pengisi bitumen melalui parameter statistik seperti pekali penentuan tertinggi ( $R^2$ ), min ralat mutlak terkecil (MAE), min ralat kuasa dua (MSE) dan punca min ralat kuasa dua (RMSE) untuk setiap model yang dibangunkan. Satu set dinamik reometer ricih (DSR) ujian data telah digunakan dalam penentuan mastic pengisi bitumen dengan tiga jenis pengisi (batu kapur, simen dan batu kersik) dan dua kepekatan pengisi (35 dan 65%). Berdasarkan analisis yang dijalankan, didapati bahawa kedua-

dua model dapat meramalkan modulus dan sudut fasa mastik pengisi bitumen dengan nilai  $R^2$  purata melebihi 0.98. Perbandingan antara kedua-dua jenis model menunjukkan bahawa asas fungsi model rangkaian jejarian mempunyai ketepatan yang lebih tinggi daripada model pelbagai lapisan rangkaian neural galakan ke hadapan dengan nilai yang lebih tinggi daripada  $R^2$  dan nilai yang lebih rendah daripada MAE, MSE dan RMSE. Dapat disimpulkan bahawa model ANN boleh digunakan sebagai kaedah alternatif untuk meramalkan sifat-sifat reologi mastic pengisi bitumen.

*Kata kunci:* Rangkaian neural tiruan, rangkaian neural galakan ke hadapan, rangkaian fungsi asas jejari, modulus kompleks ( $G^*$ ) dan sudut fasa ( $\delta$ )

© 2018 Penerbit UTM Press. All rights reserved

## 1.0 INTRODUCTION

Therefore, an effective road design is required to ensure the people life to be more efficient. The road pavement must be designed for a long time with few maintenance requirements [1]. The stiffness of asphalt pavement is depending on the thickness of each layer of pavement design methods and the type of filler used. But the basic design of the pavement is dependent on the frequency of the pavement is exposed to the vehicle load, ground support conditions and weather conditions. The flexural stiffness of the pavement is also closely related to various aspects such as rutting, the modulus of resilience and fatigue. All these aspects can be seen through the rheological properties. Bitumen-filler mastic is a combination of bitumen and mineral fillers that highly influenced its rheological properties [2]. Bitumen is a thermoplastic material that binds the aggregate to be in stable and strong condition while the mineral filler material serves to fill the airspaces between aggregate and bitumen to improve the viscosity of the bitumen thus increase the pavement durability.

When the bitumen filler mastic are subjected to the burden of recurrent or persistent pressure, it will react in an elastic at low temperatures, visco-elastic at moderate temperatures and viscous at high temperatures to which it is closely related to the stiffness. With the presence of filler mastic, the flexural stiffness of the bitumen will last longer because the main goal is to harden the bitumen in order to reduce the viscoelastic reaction of asphalt mixture or improving the elastic component and reduces the viscous component of bitumen.

Rheology refers to the study of the flow and deformation of materials under force applied routinely measured through the dynamic shear Rheometer (DSR) and dynamic mechanical analysis (DMA) tests. The DSR test (AASHTO T315-02) was used for measuring the viscoelastic properties of bituminous binders for a wide range of temperatures and frequencies (loading time) while the DMA is used to detect the rheological properties of the dynamics of bitumen through the test of the swing using the rheometer to understand the nature of viscous and

elastic bitumen (various temperature and load rate) [3]. However, recognising that testing is generally laborious, time consuming and expensive, and requiring skilled operators [4]. Predictive models such as an artificial neural network (ANN) model can be a valuable alternative tool for quantifying the rheological properties of bituminous binders including bitumen-filler mastics.

Artificial Neural Network (ANN) has been inspired by the feature found in the human brain. However, ANN structure is not as complex as the human brain neural network, but there are two similarities between biological neural networks and ANN. First, a block structure for both network is a simple counting devices (even neural network much simpler than the biological neural networks) and interconnected. Secondly, the connection between neurons will determine the function of the neural network [5]. ANN is a model which uses a combination of mathematical and simulation of biological neural system to process the information obtained to get the output in the form of predictions after the network was trained according to the data change pattern [6]. This system is able to recognize, capture and trace the pattern contained in the data set because of the high connectivity of neurons process information in parallel [7]. Therefore, at present, ANN approach be a valuable computational tool and is increasingly being used to solve complex problems as an alternative to more traditional techniques [8].

In the simplest form, ANN consists of single elements (neurons). Neurons or nerve will receive external signals and synthesize these signals into output signals. A simple conversion function is used in this process. Artificial neural networks also can be presented in a more complex form which contains a number of neurons that are connected to each other where the output signal from one neuron will be the input signal to one or more other neurons. The interaction that occurs between a large numbers of these neurons made ANN known as a model that can handle complicated and complex problem [9]. The basic structure for ANN is shown in Figure 1.

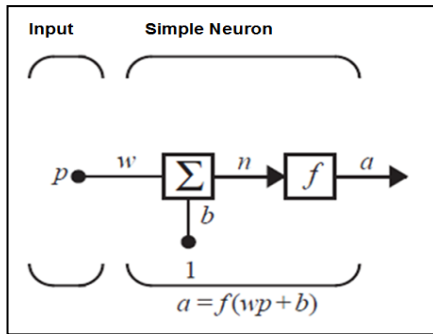

Figure 1 Basic structure of ANN

There are three different operations in a single input neuron network. The first input is scalar,  $p$  will be multiplied by the weight scalar,  $w$  to form a product,  $wp$  which is also a scalar. Both products,  $wp$  is added to the bias scalar,  $b$  to generate a net input,  $n$ . The function of the bias,  $b$  is equal to the weight,  $w$  but the value of bias is 1 and fixed. Finally, net input,  $n$  will be through the transfer function,  $f$  to produce a output scalar,  $a$ . The three processes are called 1) the weight function, 2) net input function, and 3) the transfer function [10].

Multilayer feed-forward neural network is the most widely used in prediction. It is train with a back-propagation learning algorithm, is a well-liked neural networks and it consists of neurons that are prearranged into layers as shown in the Figure 2. The first layer is a input layer, the last layer is the output layer, where  $n$  is the number of nodes of the output layer and the layers between are hidden layers [11]. It can contain more than one hidden layer but theoretical work has shown that one hidden layer is sufficient to estimate any complex nonlinear function [12].

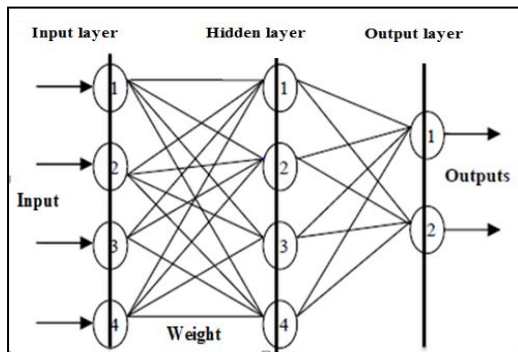

Figure 2 Multilayer feed-forward neural network structure

Generally, multilayer feed-forward neural network has multiple layers of input as  $x_j$ , ( $j = 1, 2, \dots, n$ ) which represents the input signal source. Each input can be weighted before reaching the main body of the processing elements (neurons in the hidden layer) by the connection strength or weight,  $w_j$ . Therefore, the

signal that is transmitted via the connection strength is equal to a part of the original signal,  $w_j x_j$ . In addition, the input signal to the neuron must exceed the threshold value,  $T$  or bias,  $b$  to generate neuronal signals. After the impact of bias,  $b$  in the signals has been weighted, nonlinear function,  $F$  will enter to nonlinear units and then produces an output which is output can be input to other neurons [13].

The transfer function of the neural network is given by Equation 1 below:

$$O_i = F\left(\sum_{j=1}^n (w_{ij}x_{ij})\right) \tag{1}$$

provided the conditions of neurons are same as in Equation 2 below:

$$\sum_{i=1}^n w_{ij}x_{ij} \geq T_i \tag{2}$$

where subscript  $i$  and  $j$  represents a disputed neurons and input to the neuron respectively.

Radial basis function network is a type of feed-forward neural network composed of three layers, namely the input layer, the hidden layer and the output layer. Each of these layers has different tasks[14]. Figure 3 [15] show the radial basis function neural network Structure.

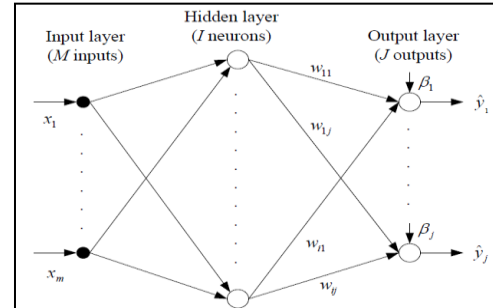

Figure 3 Radial basis function neural network structure

In the structure of the radial basis function network, data input,  $X$  is a vector of  $I$ -dimensions will be transferred to each hidden unit. The activation function of the hidden units is symmetrical in space for each input and output hidden units and is dependent on the radial distance between the input vector,  $X$  and the hidden unit. The output units for the hidden,  $h_i$  which  $i = 1, 2, \dots, i$  are as Equation 3 below:

$$h_i(x) = \phi(\|x - c_i\|) \tag{3}$$

where  $\| \cdot \|$  is Euclidean Norm,  $c_i$  is central neurons in the hidden layer and  $\phi(\cdot)$  is the activation function where it is nonlinear function such as a gaussian kernel function, multiquadric, thinspline and



exponential functions. Gaussian kernel function is a popular function used as transformer function in the hidden layer. The activation Gaussian kernel function are Expressed in equation 4:

$$\phi(x) = \exp\left[-\frac{\|x - c_i\|^2}{2\rho^2}\right] \quad (4)$$

Where  $x$  is the training data and  $\rho$  is the width of the Gaussian Kernel function. In radial basis function neural networks, the outputs of the input layer are determined by calculating the distance between the network inputs and hidden layer. The second layer is the linear hidden layer and outputs of this layer are weighted forms of the input layer outputs. Each neuron of the hidden layer has a parameter vector called center. The center and width of the kernel will join with each hidden unit in the network. Weight that connecting the hidden units and the output are estimated by the least min squares method. Finally, the reaction of each hidden unit is scaled by the weight of the connection to the output unit and it summed to generate a total output [16]. Therefore,  $k$ , the output of  $\hat{y}_k$  is such in equation 5 below:

$$\hat{y}_k = \sum_{i=1}^I w_{ij} \phi_i(x) + \beta_i \quad (5)$$

## 2.0 METHODOLOGY

This study is a contrived study using data measured from a laboratory experiment. The research framework of this study is shown in Figure 4.

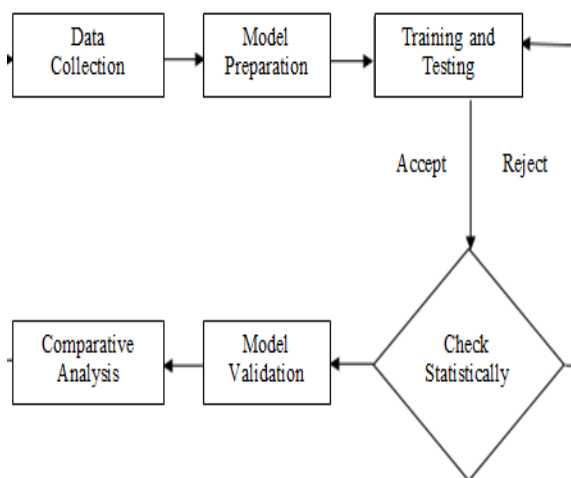

Figure 4 Research framework of this study

A set of dynamic shear rheometer (DSR) test data was used on a range of the bitumen-filler mastics with three filler types (limestone, cement and grit stone)

and two filler concentrations (35 and 65% by mass). The amount of data used in this study is 1583 data. The data divided into three, namely 70% of the data used for model training process. A total of 15% would be used for model validation process and another 15% used for the testing process model. From 1583 data, a total of 1107 data used for the training process model, data 238 to be used for model validation process and 238 more data used for the testing process model. The division of the data is randomly according to the system used in MATLAB

The process involves in the ANN model preparation are the determination of the number of hidden layer in the models, the number of neuron in each hidden layer and the transfer function of the neural network multi-layer feed-forward and involves the determination of the spread value of radial basis function network. In MATLAB, each neural network has also been designed as a GUI (graphical user interface) with specific functions. This GUI that used in the preparation of model.

There are two neural network model used in the process of analyzing the data in this study name as neural network model multi-layer feed-forward and radial basis function network model. These models select data, create and train networks, and evaluate its performance using the mean squared error and regression analysis.

For multilayer feed-forward neural network model system has been designed in a toolbox. It can be used by typing 'nftool' in the command window and the algorithm that used in this model is the Levenberg-Marquardt. Training on data can be repeated until the optimal results of the  $R^2$  and MSE obtained. The structure is a model that has been designed as in Table 1.

Table 1 Structure of the network and the transfer function of ANN model

Subject	Transfer function
Input Layer	-
Hidden Layer	Sigmoid
Output Layer	Linear

Then, for radial basis function neural network has been designed to function 'newrb' and will be called as shown in Equation 6.

$$\text{net} = \text{newrb}(P, T, \text{goal}, \text{spread}, \text{MN}, \text{DF}) \quad (6)$$

where:

- $P$  = input vector matrix
- $T$  = target vector matrix
- $\text{goal}$  = mean squared error goal
- $\text{spread}$  = spread of radial basis function
- $\text{MN}$  = Maximum number of neurons
- $\text{DF}$  = number of neurons to display



The optimal dispersion will produce the best approximation of a function. However, many neurons are needed to meet the rapid change if the dispersion is too large. If dispersion is too small, many neurons are needed to cater the function well or it may not be able to produce a good network. Therefore, *newrb* function shall be called by different dispersion (spread) in order to find the best solution to a problem.

From 1583 data, 70% of the data involved in the training process as training set. Training set trained by using specific training algorithms until it achieve a minimum error. In the training process, the model try to learn the relationship between the input data and the output data and try minimized the difference between the target data and the predicted data. After that, further testing carried out to the other 15% of the data. This test based on the developed model in the training process. Training and testing process repeatedly done by changing the model parameters such as the number of neuron involve and the type of membership function used until the analysis produces an optimum output with the most minimum error. The division of data either it involve in training process or testing process is random.

Model validation process carried out after the optimum output from the training and testing is achieved. Validation is necessary to ensure the accuracy of the developed model. In this study, coefficient of determination,  $R^2$  is used to evaluate the accuracy of the developed model. Meanwhile, the mean absolute error (MAE), mean squared error (MSE) and the root mean squared error (RMSE) is calculate to determine the most accurate model to predict the complex modulus,  $G^*$  and phase angle,  $\delta$  of the bitumen filler mastic.

1. Coefficient of determination,  $R^2$

$$\left( R^2 = 1 - \frac{\sum_{i=1}^n (x-y)^2}{\sum_{i=1}^n (x-z)^2} \right) \quad (7)$$

2. Mean absolute error, MAE

$$\left( MAE = \frac{1}{n} \sum_{i=1}^n |x - y| \right) \quad (8)$$

3. Mean squared error, MSE

$$\left( MSE = \frac{1}{n} \sum_{i=1}^n (x - y)^2 \right) \quad (9)$$

4. Root mean squared error, RMSE

$$\left( RMSE = \sqrt{\frac{\sum_{i=1}^n (x-y)^2}{n}} \right) \quad (10)$$

Where  $x$  is predicted value,  $y$  is actual value,  $z$  is average of actual value and  $n$  is number of data.

### 3.0 RESULTS AND DISCUSSION

Two models have been developed for multilayer feed-forward neural networks to prediction 1) the value of the complex modulus,  $G^*$ , and 2) the value of the phase angle  $\delta$  of three different types of bitumen filled mastic in terms of the percentage of modifier and a control sample. Based on the results obtained from these models, the best network structure derived to predict the value of the complex modulus,  $G^*$  and phase angle,  $\delta$  is 3-20-1 and 3-15-1. Table 2 describes the network structure and the transfer function used in this network.

**Table 2** Structure of the network and the transfer function of multilayer feed-forward model

Item	Complex Modulus, $G^*$		Phase Angle, $\delta$	
	No. of Neuron	Transfer Function	No. of Neuron	Transfer Function
Input layer	3	-	3	-
Hidden layer	20	Log-sigmoid	15	Log-sigmoid
Output layer	1	Linear	1	Linear

Proportions graph are plotted to compare the results derived from developed model and experimental results in the laboratory.

#### Result for Multilayer Feed-Forward Neural Network

Figures 5 show the predicted values against actual values of complex modulus,  $G^*$  while Figure 6 shows the predicted values against actual values of phase angle,  $\delta$  of bitumen filler mastic using multilayer feed-forward model. The point that scattered in the Figure 5 shows the proportion between predicted data and actual data, while a straight line present as a corresponding line that shows similarities between the actual data and predicted data. From Figure 5 and 6, the predicted value using this network model approached perfection where the value of coefficient of determination,  $R^2$  for both is closer to 1.00 in the range of 0.98 to 1.00.

The mean absolute error (MAE) was used to calculate the average error between the actual data and predicted data. The MAE obtained from the calculation is 623 kPa for the modulus complex,  $G^*$  and 0.76° for the phase angle,  $\delta$ . The small value of MAE shows that the structure of the network model has been designed with good form. Mean squared error (MSE) is similar with the square root of the mean error (RMSE). The RMSE obtained is 1778 kPa for the complex modulus,  $E^*$  and 1.26° to the phase angle  $\delta$  the value of which is used to measure the accuracy of the model.

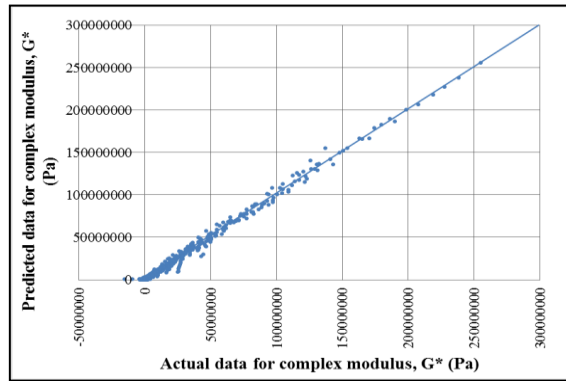

**Figure 5** Graph of predicted value against actual value for complex modulus,  $G^*$  using multilayer feed-forward neural network model

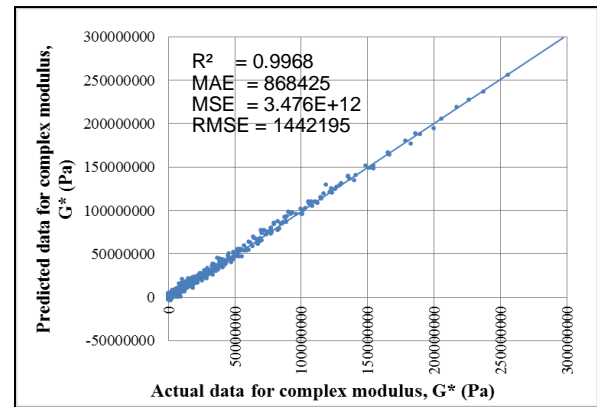

**Figure 7** Graph of predicted value against actual value for complex modulus,  $G^*$  using radial basis function neural network model

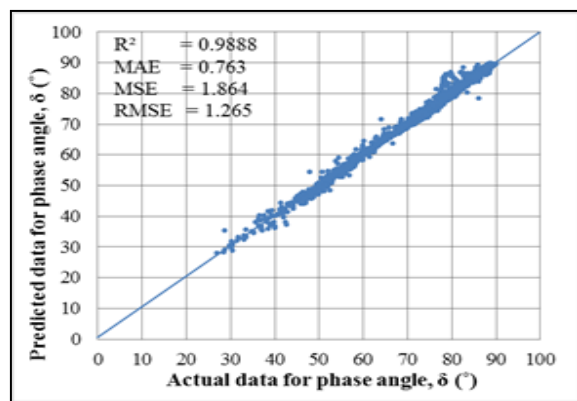

**Figure 6** Graph of predicted value against actual value for of phase angle,  $\delta$  using multilayer feed-forward neural network model

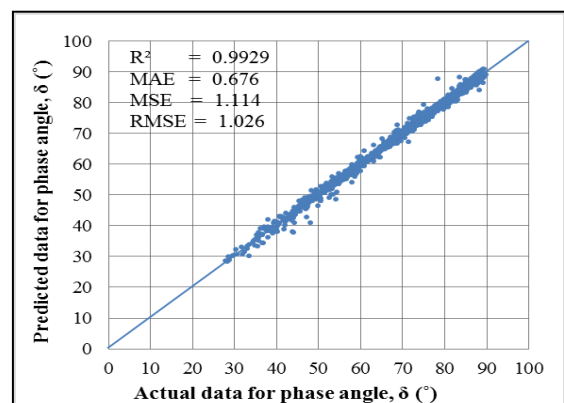

**Figure 8** Graph of predicted value against actual value for of phase angle,  $\delta$  using radial basis function neural network model

### Result for Radial Basis Function Neural Network

The best results for models that have been developed were obtained from the determination of spread values through trial and error method. Figures 7 show the predicted values against actual values of complex modulus,  $G^*$  while Figure 8 shows the predicted values against actual values of phase angle,  $\delta$  of bitumen filler mastic using radial basis function model. This model is also good in predict the value of the complex modulus,  $G^*$  and phase angle,  $\delta$  as the value of  $R^2$  obtained were approaching 1. The values are 0.9968 and 0.9929 respectively.

The average error between the predicted data and the actual data or MAE value is small which is 868 kPa for the modulus complex,  $G^*$  and  $0.676^\circ$  for the phase angle,  $\delta$  while the MSE for the complex modulus,  $G^*$  and the phase angle,  $\delta$  is  $3.476E+12$  Pa and  $1.114^\circ$ , respectively. The value will be squared to get RMSE of 14421 kPa of the complex modulus,  $G^*$  and  $1.026^\circ$  for the phase angle,  $\delta$ . Figure 7 also shows that the majority of such data is on the line where it is shown that the predicted data is directly proportional to the actual data.

### Statistical Analysis

Based on the analysis, it can be proved that the developed models are able to predict the complex modulus,  $G^*$  and phase angle,  $\delta$  of bitumen filler mastic well. This is shown on Table 3, where the value of  $R^2$  for both model is closer to 1.00 in the range of 0.98 to 1.00. This value indicates that both models have high accuracy in making the prediction.

Comparison between the two models the value of  $R^2$  for radial basis function neural network model is higher than multilayer feed-forward neural network model as the value is almost approaching 1.00. Besides, the MAE, MSE and RMSE of radial basis function neural network model also lower than multilayer feed-forward neural network model. With this reasons, it can be concluded that radial basis function neural network model can predict the complex modulus,  $G^*$  and phase angle,  $\delta$  better than the multilayer feed-forward neural network model because high  $R^2$  value and a small RMSE values shows that the accuracy of the model is very high [18].

**Table 3** Values for  $R^2$ , MAE, MSE and RMSE

	$R^2$	MAE	MSE	RMSE
<u>Complex modulus, <math>G^*</math>:</u>				
Multilayer feed-forward neural network model.				
	0.9956	623856	4.893E+12	1778812
Radial basis function Neural network model				
	0.9968	86425	4.476E+12	1442195
<u>Phase angle, <math>\delta</math>:</u>				
Multilayer feed-forward neural network model.				
	0.9888	0.763	1.864	1.265
Radial basis function Neural network model				
	0.9929	0.676	1.114	1.026

Comparisons have been made with studies performed by Hamim [16] on the study of rheological properties of asphalt mixture using artificial neural network. This study also uses two types of ANN model of neural network namely multi-layer feed-forward network and radial basis function to predict dynamic modulus,  $E^*$  and the phase angle,  $\delta$  for asphalt pavement. Results from this study are shown in Table 5.

**Table 4** The Coefficient of Determination Value,  $R^2$ 

Item	$R^2$
<u>Complex modulus, <math>E^*</math></u>	
Multi-Layer Feed-Forward Network	0.9947
Radial Basis Function Network	0.9953
<u>Phase angle, <math>\delta</math></u>	
Multi-Layer Feed-Forward Network	0.9977
Radial Basis Function Network	0.9997

From Table 4, it can be seen that the developed model in this study has a very high accuracy in predicting the value of the complex modulus,  $G^*$  as the average value of  $R^2$  generated is very close to the value of 1.0 compared to the value of  $R^2$  to the dynamic modulus,  $E^*$  generated in Table 5. However, in this study the average  $R^2$  value obtained is low in predicting the value of the phase angle,  $\delta$  compared with the values in Table 4, which is in the range of 0.9888-0.9929. This occurs because the experiments conducted by Hamim [16], complex modulus data that used is in the range of hundred while the complex modulus data developed in this study were within the range of millions. Furthermore,

the number of neurons in the hidden layer of the phase angle used in the Hamim's study is 11, while the number of neurons in the hidden layer used in this study is 15. The range of data and no of neurons in the hidden layer are the factors that influence the accuracy of ANN model [19].

In addition, comparisons were also made on the RMSE value obtained from this study and studies that have been conducted by Xiao *et al.* [20]. It was found that RMSE obtained from previous studies in measuring the stiffness behavior of rubberized asphalt concrete mixture of cryogen at a temperature of 5 °C is 0.81 MPa, which is in the range of stiffness values between 0 to 30 MPa.

The RMSE value is 2.7% of the maximum range of the strength of the mixture. While in this study, the average RMSE values obtained for the complex modulus of both models is of 1.61 MPa in the range of stiffness values between 0 to 255.63 MPa and is 0.63% of the maximum range value of the stiffness. From the comparison that has been made, it was found RMSE for this study is lower compared to studies conducted by Xiao *et al.* [20] The lower RMSE value is preferable to developed a model.

## 4.0 CONCLUSION

In conclusion, it was found that the analysis process shows that radial basis function neural network model had a better accuracy in the prediction of the complex modulus,  $G^*$  and phase angle,  $\delta$  compared to multilayer feed-forward neural network model. These studies also reinforces the evidence that the neural network model either radial basis function neural network model or multilayer feed-forward neural network model is able to predict the complex modulus,  $G^*$  and phase angle,  $\delta$  for the bitumen filler mastic well and it can be inferred that the neural network models have an excellent potential to replace the existing analytical and empirical models in predicting the rheological properties of bitumen filler mastic.

## Acknowledgement

This research is fully supported by FRGS grant, (FRGS/1/2014/TK07/JPP/03/1). The authors fully acknowledged Ministry of Higher Education (MOHE) and Universiti Kebangsaan Malaysia for the approved fund which makes this important research viable and effective.

## References

- [1] Morse, A. A. & Green, R. L. 2009. Pavement Design and Rehabilitation. Dlm. Brockenbrough, R. (ed.). Highway. 223-237. United State: McGraw-Hill.

- [2] Anderson, D. A. 1987. Guidelines for Use of Dust in Hot-Mix Asphalt Concrete Mixtures. *Journal of the Association of Asphalt Paving Technologists*. 56: 492-516.
- [3] Airey, G. D. 1997. Rheological Characteristics of Polymer Modified and Aged Bitumens. Tesis Ph.D. Jabatan Kejuruteraan Awam, Universiti Nottingham, United Kingdom.
- [4] Zeghal, M. 2008. Visco-elastic Portrayal of Bituminous Materials: Artificial Neural Network Approach. *Proceedings of GeoCongress*. New Orleans, Louisiana, 9-12 Mac.
- [5] Hagan, M. T., Demuth, H. B. & Beale, M. H. 1996. *Neural Network Design*. PWS Publishing.
- [6] Thube, D. T. 2012. Artificial Neural Network (ANN) based Pavement Deterioration Models for Low Volume Roads in India. *International Journal of Pavement Research and Technology*. 5(2): 115-120.
- [7] Abo-hashema, M. 2009. Artificial Neural Network Approach for Overlay Design of Flexible Pavements. *The International Arab Journal of Information Technology*. 6(2): 204-212.
- [8] Martínez, F. & Angelone, S. 2009. The Estimation of the Dynamic Modulus of Asphalt Mixtures Using Artificial Neural Networks. Road Laboratory, School of Engineering, University of Rosario, Argentina.
- [9] Hassan, H. F. 2010. Artificial Neural Network Technique for Rainfall Forecasting Applied to Alexandria, Egypt. Tesis Master, Jabatan Kejuruteraan Awam & Struktur, Universiti Kebangsaan Malaysia.
- [10] Beale, M. H., Hagan, M. T. & Demuth, H. B. 2012. *Neural Network Toolbox™ User's Guide*. Natick: The MathWorks, Inc.
- [11] Svozil, D., Vladimir Kvasnička, Jiří Pospíchal 1997. Introduction to Multi-layer Feed-forward Neural Networks. *Chemometrics and Intelligent Laboratory Systems*. 39: 43-62.
- [12] Hornik, K., Stinchcombe, M. & White, H. 1989. Multilayer Feedforward Networks are Universal Approximators. *Neural Networks*. 2: 359-366.
- [13] Saltan, M., Tiğdemir, M. & Kardeş, M. 2002. Artificial Neural Network Application for Flexible Pavement Thickness Modeling. *Turkish Journal Engineering & Environmental Sciences*. 26: 243-248.
- [14] Yu, B., He, X. 2006. Training Radial Basis Function Networks with Differential Evolution. *Proceedings of IEEE International Conference on Granular Computing*, Atlanta, GA, US. 369-372.
- [15] Tuba Kurban and Erkan Beşdok 2009. A Comparison of RBF Neural Network Training Algorithms for Inertial Sensor Based Terrain Classification. *Journal of Sensors*. 9: 6312-6329.
- [16] Hamim. 2009. Ramalan Ciri-ciri Reologi Campuran Berasphalt Menggunakan Rangkaian Saraf Tiruan. Tesis Master, Jabatan Kejuruteraan Awam dan Struktur, Universiti Kebangsaan Malaysia.
- [17] Min-Chih Liao, Jian-Shiuh Chen, Gordon Airey and Shi-Jing Wang. 2014. Rheological Behavior of Bitumen Mixed with Trinidad Lake Asphalt. *Construction and Building Materials*. 66: 361-367.
- [18] Sobhani, J., Najimi, M., Pourkhorshidi, A. R., & Parhizkar, T. 2010. Prediction of the Compressive Strength of No-Slump Concrete: A Comparative Study of Regression, Neural Network and ANFIS Models. *Construction and Building Materials*. 24(5): 709-718.
- [19] Tiwari, K. C. 2001. Neural Network Parameter Affecting Image Classification. *Journal of Defense Science*. 51: 263-278.
- [20] Xiao, F. & Amirhanian, S. N. 2009. Artificial Neural Network Approach to Estimating Stiffness Behavior of Rubberized Asphalt Concrete Containing Reclaimed Asphalt Pavement. *Journal of Transportation Engineering*. 135(8): 580-589.



# PREDICTING THE RHEOLOGICAL PROPERTIES

*by* J Teknologi Vol.80 No.1

---

**Submission date:** 03-Mar-2020 11:53AM (UTC+0700)

**Submission ID:** 1268223056

**File name:** 11097-34421-1-PB.pdf (612.8K)

**Word count:** 4866

**Character count:** 25299

## PREDICTING THE RHEOLOGICAL PROPERTIES OF BITUMEN-FILLER MASTIC USING ARTIFICIAL NEURAL NETWORK METHODS

Nursyahirah Khamis<sup>a</sup>, Muhamad Razuhanafi Mat Yazid<sup>a\*</sup>, Asmah Hamim<sup>a</sup>, Sri Atmaja P. Rosyidi<sup>b</sup>, Nur Izzī Md. Yusoff<sup>a</sup>, Muhamad Nazri Borhan<sup>a</sup>

<sup>a</sup>Department of Civil & Structural Engineering, Faculty of Engineering & Built Environment, Universiti Kebangsaan Malaysia, 43600, Bangi, Selangor, Malaysia

<sup>b</sup>Department of Civil Engineering, Universitas Muhammadiyah Yogyakarta, Indonesia

### Article history

Received  
23 May 2017  
Received in revised form  
24 July 2017  
Accepted  
1 November 2017

\*Corresponding author  
razuhanafi@ukm.edu.my

### Graphical abstract

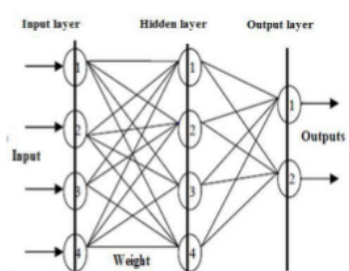

### Abstract

This study was conducted to develop two types of artificial neural network (ANN) model to predict the rheological properties of bitumen-filler mastic in terms of the complex modulus and phase angle. Two types of ANN models were developed namely: (i) a multilayer feed-forward neural network model and (ii) a radial basis function network model. This study was also conducted to evaluate the accuracy of both types of models in predicting the rheological properties of bitumen-filler mastics by means of statistical parameters such as the coefficient of determination ( $R^2$ ), mean absolute error (MAE), mean squared error (MSE) and root mean squared error (RMSE) for every developed model. A set of dynamic shear rheometer (DSR) test data was used on a range of the bitumen-filler mastics with three filler types (limestone, cement and grit stone) and two filler concentrations (35 and 65% by mass). Based on the analysis performed, it was found that both models were able to predict the complex modulus and phase angle of bitumen-filler mastics with the average  $R^2$  value exceeding 0.98. A comparison between the two types of models showed that the radial basis function network model has a higher accuracy than multilayer feed-forward neural network model with a higher value of  $R^2$  and lower value of MAE, MSE and RMSE. It can be concluded that the ANN model can be used as an alternative method to predict the rheological properties of bitumen-filler mastic.

Keywords: Artificial neural network, multilayer feed-forward neural network, radial basis function network, complex modulus ( $G^*$ ) and phase angle ( $\delta$ )

### Abstrak

Kajian ini dijalankan untuk membangunkan dua jenis peramalan model berdasarkan pendekatan rangkaian neuron tiruan (ANN) untuk meramalkan sifat-sifat reologi mastik-pengisi bitumen dari segi modulus dan sudut fasa yang kompleks. Dua jenis model ANN telah dibangunkan iaitu; (i) suatu model rangkaian neural galakan ke hadapan pelbagai lapisan dan (ii) model rangkaian fungsi asas jejarian. Kajian ini juga dijalankan untuk menilai ketepatan kedua-dua jenis model untuk meramalkan sifat-sifat reologi mastik pengisi bitumen melalui parameter statistik seperti pekali penentuan tertinggi ( $R^2$ ), min ralat mutlak terkecil (MAE), min ralat kuasa dua (MSE) dan punca min ralat kuasa dua (RMSE) untuk setiap model yang dibangunkan. Satu set dinamik reometer ricih (DSR) ujian data telah digunakan dalam penentuan mastic pengisi bitumen dengan tiga jenis pengisi (batu kapur, simen dan batu kersik) dan dua kepekatan pengisi (35 dan 65%). Berdasarkan analisis yang dijalankan, didapati bahawa kedua-

dua model dapat meramalkan modulus dan sudut fasa mastik pengisi bitumen dengan nilai  $R^2$  purata melebihi 0.98. Perbandingan antara kedua-dua jenis model menunjukkan bahawa asas fungsi model rangkaian jejarian mempunyai ketepatan yang lebih tinggi daripada model pelbagai lapisan rangkaian neural galakan ke hadapan dengan nilai yang lebih tinggi daripada  $R^2$  dan nilai yang lebih rendah daripada MAE, MSE dan RMSE. Dapat disimpulkan bahawa model ANN boleh digunakan sebagai kaedah alternatif untuk meramalkan sifat-sifat reologi mastik pengisi bitumen.

**Kata kunci:** Rangkaian neural tiruan, rangkaian neural galakan ke hadapan, rangkaian fungsi asas jejari, modulus kompleks ( $G^*$ ) dan sudut fasa ( $\delta$ )

© 2018 Penerbit UTM Press. All rights reserved

## 1.0 INTRODUCTION

Therefore, an effective road design is required to ensure the people life to be more efficient. The road pavement must be designed for a long time with few maintenance requirements [1]. The stiffness of asphalt pavement is depending on the thickness of each layer of pavement design methods and the type of filler used. But the basic design of the pavement is dependent on the frequency of the pavement is exposed to the vehicle load, ground support conditions and weather conditions. The flexural stiffness of the pavement is also closely related to various aspects such as rutting, the modulus of resilience and fatigue. All these aspects can be seen through the rheological properties. Bitumen-filler mastic is a combination of bitumen and mineral fillers that highly influenced it rheological properties [2]. Bitumen is a thermoplastic material that binds the aggregate to be in stable and strong condition while the mineral filler material serves to fill the airspaces between aggregate and bitumen to improve the viscosity of the bitumen thus increase the pavement durability.

When the bitumen filler mastic are subjected to the burden of current or persistent pressure, it will react in an elastic at low temperatures, viscoelastic at moderate temperatures and viscous at high temperatures to which it is closely related to the stiffness. With the presence of filler mastic, the flexural stiffness of the bitumen will last longer because the main goal is to harden the bitumen in order to reduce the viscoelastic reaction of asphalt mixture or improving the elastic component and reduces the viscous component of bitumen.

Rheology refers to the study of the flow and deformation of materials under force applied routinely measured through the dynamic shear Rheometer (DSR) and dynamic mechanical analysis (DMA) tests. The DSR test (AASHTO T31) was used for measuring the viscoelastic properties of bituminous binders for a wide range of temperatures and frequencies (loading time) while the DMA is used to detect the rheological properties of the dynamics of bitumen through the test of the swing using the rheometer to understand the nature of viscous and

elastic bitumen (various temperature and load rate) [3]. However, recognising that testing is generally laborious, time consuming and expensive, and requiring skilled operators [4]. Predictive models such an artificial neural network (ANN) model can be a valuable alternative tool for quantifying the rheological properties of bituminous binders including bitumen-filler mastics.

Artificial Neural Network (ANN) has been inspired by the feature found in the human brain. However, ANN structure is not as complex as the human brain neural network, but there are two similarities between biological neural networks and ANN. First, a block structure for both network is a simple counting devices (even neural network much simpler than the biological neural networks) and interconnected. Secondly, the connection between neurons will determine the function of the neural network [5]. ANN is a model which uses a combination of mathematical and simulation of biological neural system to process the information obtained to get the output in the form of predictions after the network was trained according to the data change pattern [6]. This system is able to recognize, capture and trace the pattern contained in the data set because of the high connectivity of neurons process information in parallel [7]. Therefore, at present, ANN approach be a valuable computational tool and is increasingly being used to solve complex problems as an alternative to more traditional techniques [8].

In the simplest form, ANN consists of single elements (neurons). Neurons or nerve will receive external signals and synthesize these signals into output signals. A simple conversion function is used in this process. Artificial neural networks also can be presented in a more complex form which contains a number of neurons that are connected to each other where the output signal from one neuron will be the input signal to one or more other neurons. The interaction that occurs between a large numbers of these neurons made ANN known as a model that can handle complicated and complex problem [9]. The basic structure for ANN is shown in Figure 1.

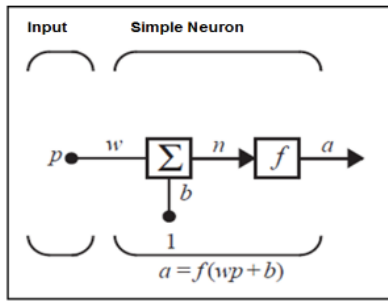

Figure 1 Basic structure of ANN

There are three different operations in a single input neuron network. The first is scalar,  $p$  will be multiplied by the weight scalar,  $w$  to form a product,  $wp$  which is also a scalar. Both products,  $wp$  is added to the bias scalar,  $b$  to generate a net input,  $n$ . The function of the bias,  $b$  is equal to the weight,  $w$  but the value of bias is 1 and fixed. Finally, net input,  $n$  will be through the transfer function,  $f$  to produce a output scalar,  $a$ . The three processes are called 1) the weight function, 2) net input function, and 3) the transfer function [10].

Multilayer feed-forward neural network is the most widely used in prediction. It is train with a back-propagation learning algorithm, is a well-liked neural networks and it consists of neurons that are prearranged into layers as shown in the Figure 2. The first layer is a input layer, the last layer is the output layer, where  $n$  is the number of nodes of the output layer and the layers between are hidden layers [11]. It can contain more than one hidden layer but theoretical work has shown that one hidden layer is sufficient to estimate any complex nonlinear function [12].

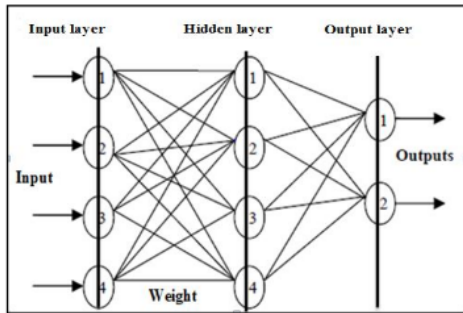

Figure 2 Multilayer feed-forward neural network structure

Generally, multilayer feed-forward neural network has multiple layers of input as  $x_j$ , ( $j = 1, 2, \dots, n$ ) which represents the input signal source. Each input can be weighted before reaching the main body of the processing elements (neurons in the hidden layer) by the connection strength or weight,  $w_j$ . Therefore, the

signal that is transmitted via the connection strength is equal to a part of the original signal,  $w_j x_j$ . In addition, the input signal to the neuron must exceed the threshold value,  $T$  or bias,  $b$  to generate neuronal signals. After the impact of bias,  $b$  in the signals has been weighted, nonlinear function,  $F$  will enter to nonlinear units and then produces an output which is output can be input to other neurons [13].

The transfer function of the neural network is given by Equation 1 below:

$$O_i = F\left(\sum_{j=1}^n (w_{ij} x_{ij})\right) \tag{1}$$

provided the conditions of neurons are same as in Equation 2 below:

$$\sum_{i=1}^n w_{ij} x_{ij} \geq T_i \tag{2}$$

where subscript  $i$  and  $j$  represents a disputed neurons and input to the neuron respectively.

Radial basis function network is a type of feed-forward neural network composed of three layers, namely the input layer, the hidden layer and the output layer. Each of these layers has different tasks [14]. Figure 3 [15] show the radial basis function neural network Structure.

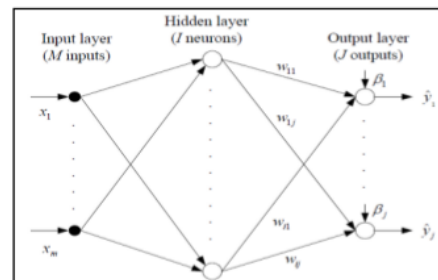

Figure 3 Radial basis function neural network structure

In the structure of the radial basis function network, data input,  $X$  is a vector of  $l$ -dimensions will be transferred to each hidden unit. The activation function of the hidden units is symmetrical in space for each input and output hidden units and is dependent on the radial distance between the input vector,  $X$  and the hidden unit. The output units for the hidden,  $h_i$  which  $i = 1, 2, \dots, i$  are as Equation 3 below:

$$h_i(x) = \phi(\|x - c_i\|) \tag{3}$$

where  $\| \cdot \|$  is Euclidean Norm,  $c_i$  is central neurons in the hidden layer and  $\phi(\cdot)$  is the activation function where it is nonlinear function such as a gaussian kernel function, multiquadric, thinspline and



exponential functions. Gaussian kernel function is a popular function used as transfer function in the hidden layer. The activation Gaussian kernel function are expressed in equation 4:

$$\phi(x) = \exp\left[-\frac{\|x-ci\|^2}{2p^2}\right] \quad (4)$$

Where  $x$  is the training data and  $p$  is the width of the Gaussian Kernel function. In radial basis function neural networks, the outputs of the input layer are determined by calculating the distance between the network inputs and hidden layer. The second layer is the linear hidden layer and outputs of this layer are weighted forms of the input layer outputs. Each neuron of the hidden layer has a parameter vector called center. The center and width of the kernel will connect with each hidden unit in the network. Weight that connecting the hidden units and the output are estimated by the least min squares method. Finally, the reaction of each hidden unit is scaled by the weight of the connection to the output unit and it summed to generate a total output [16]. Therefore,  $k$ , the output of  $\hat{y}_k$  is such in equation 5 below:

$$\hat{y}_k = \sum_{i=1}^I w_{ij} \phi_i(x) + \beta_i \quad (5)$$

## 2.0 METHODOLOGY

This study is a contrived study using data measured from a laboratory experiment. The research framework of this study is shown in Figure 4.

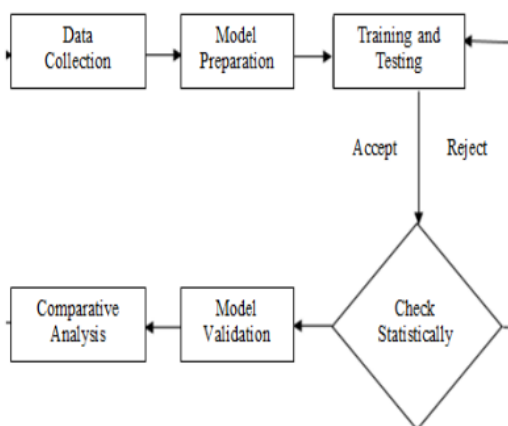

Figure 4 Research framework of this study

A set of dynamic shear rheometer (DSR) test data was used on a range of the bitumen-filler mastics with three filler types (limestone, cement and grit stone)

and two filler concentrations (35 and 65% by mass). The amount of data used in this study is 1583 data. The data divided into three, namely 70% of the data used for model training process. A total of 15% would be used for model validation process and another 15% used for the testing process model. From 1583 data, a total of 1107 data used for the training process model, data 238 to be used for model validation process and 238 more data used for the testing process model. The division of the data is randomly according to the system used in MATLAB.

The process involves in the ANN model preparation are the determination of the number of hidden layer in the models, the number of neuron in each hidden layer and the transfer function of the neural network multi-layer feed-forward and involves the determination of the spread value of radial basis function network. In MATLAB, each neural network has also been designed as a GUI (graphical user interface) with specific functions. This GUI that used in the preparation of model.

There are two neural network model used in the process of analyzing the data in this study name as neural network model multi-layer feed-forward and radial basis function network model. These models select data, create and train networks, and evaluate its performance using the mean squared error and regression analysis.

For multilayer feed-forward neural network model system has been designed in a toolbox. It can be used by typing 'nftool' in the command window and the algorithm that used in this model is the Levenberg-Marquardt. Training on data can be repeated until the optimal results of the  $R^2$  and MSE obtained. The structure is a model that has been designed as in Table 1.

Table 1 Structure of the network and the transfer function of ANN model

Subject	Transfer function
Input Layer	
Hidden Layer	Sigmoid
Output Layer	Linear

Then, for radial basis function neural network has been designed to function 'newrb' and will be called as shown in Equation 6.

$$\text{net} = \text{newrb}(P, T, \text{goal}, \text{spread}, MN, DF) \quad (6)$$

where:

$P$  = input vector matrix

$T$  = target vector matrix

goal = mean squared error goal

spread = spread of radial basis function

$MN$  = Maximum number of neurons

$DF$  = number of neurons to display

The optimal dispersion will produce the best approximation of a function. However, many neurons are needed to meet the rapid change if the dispersion is too large. If dispersion is too small, many neurons are needed to cater the function well or it may not be able to produce a good network. Therefore, newrb function shall be called by different dispersion (spread) in order to find the best solution to a problem.

From 1583 data, 70% of the data involved in the training process as training set. Training set trained by using specific training algorithms until it achieve a minimum error. In the training process, the model try to learn the relationship between the input data and the output data and try minimized the difference between the target data and the predicted data. After that, further testing carried out to the other 15% of the data. This test based on the developed model in the training process. Training and testing process repeatedly done by changing the model parameters such as the number of neuron involve and the type of membership function used until the analysis produces an optimum output with the most minimum error. The division of data either it involve in training process or testing process is random.

Model validation process carried out after the optimum output from the training and testing is achieved. Validation is necessary to ensure the accuracy of the developed model. In this study, coefficient of determination,  $R^2$  is used to evaluate the accuracy of the developed model. Meanwhile, mean absolute error (MAE), mean squared error (MSE) and the root mean squared error (RMSE) is calculate to determine the most accurate model to predict the complex modulus,  $G^*$  and phase angle,  $\delta$  of the bitumen filler mastic.

1. Coefficient of determination,  $R^2$

$$\left( R^2 = 1 - \frac{\sum_{i=1}^n (x-y)^2}{\sum_{i=1}^n (x-z)^2} \right) \quad (7)$$

2. Mean absolute error, MAE

$$\left( MAE = \frac{1}{n} \sum_{i=1}^n |x - y| \right) \quad (8)$$

3. Mean squared error, MSE

$$\left( MSE = \frac{1}{n} \sum_{i=1}^n (x - y)^2 \right) \quad (9)$$

4. Root mean squared error, RMSE

$$\left( RMSE = \sqrt{\frac{\sum_{i=1}^n (x-y)^2}{n}} \right) \quad (10)$$

Where x is predicted value, y is actual value, z is average of actual value and n is number of data.

### 3.0 RESULTS AND DISCUSSION

Two models have been developed for multilayer feed-forward neural networks to prediction 1) the value of the complex modulus,  $G^*$ , and 2) the value of the phase angle  $\delta$  of three different types of bitumen filled mastic in terms of the percentage of modifier and a control sample. Based on the results obtained from these models, the best network structure derived to predict the value of the complex modulus,  $G^*$  and phase angle,  $\delta$  is 3-20-1 and 3-15-1. Table 2 describes the network structure and the transfer function used in this network.

**Table 2** Structure of the network and the transfer function of multilayer feed-forward model

Item	Complex Modulus, $G^*$		Phase Angle, $\delta$	
	No. of Neuron	Transfer Function	No. of Neuron	Transfer Function
Input layer	3	-	3	-
Hidden layer	20	Log-sigmoid	15	Log-sigmoid
Output layer	1	Linear	1	Linear

Proportions graph are plotted to compare the results derived from developed model and experimental results in the laboratory.

#### Result for Multilayer Feed-Forward Neural Network

Figures 5 show the predicted values against actual values of complex modulus,  $G^*$  while Figure 6 shows the predicted values against actual values of phase angle,  $\delta$  of bitumen filler mastic using multilayer feed-forward model. The point that scattered in the Figure 5 shows the proportion between predicted data and actual data, while a straight line present as a corresponding line that shows similarities between the actual data and predicted data. From Figure 5 and 6, the predicted value using this network model approached perfection where the value of coefficient of determination,  $R^2$  for both is closer to 1.00 in the range of 0.98 to 1.00.

The mean absolute error (MAE) was used to calculate the average error between the actual data and predicted data. The MAE obtained from the calculation is 623 kPa for the modulus complex,  $G^*$  and  $0.76^\circ$  for the phase angle,  $\delta$ . The small value of MAE shows that the structure of the network model has been designed with good form. Mean squared error (MSE) is similar with the square root of the mean error (RMSE). The RMSE obtained is 778 kPa for the complex modulus,  $E^*$  and  $1.26^\circ$  to the phase angle  $\delta$  the value of which is used to measure the accuracy of the model.

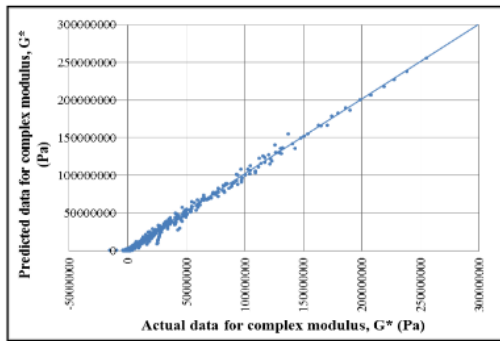

**Figure 5** Graph of predicted value against actual value for complex modulus,  $G^*$  using multilayer feed-forward neural network model

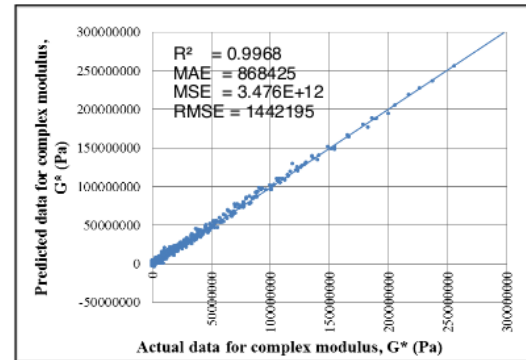

**Figure 7** Graph of predicted value against actual value for complex modulus,  $G^*$  using radial basis function neural network model

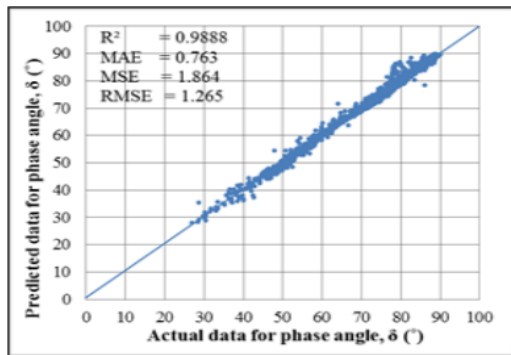

**Figure 6** Graph of predicted value against actual value for phase angle,  $\delta$  using multilayer feed-forward neural network model

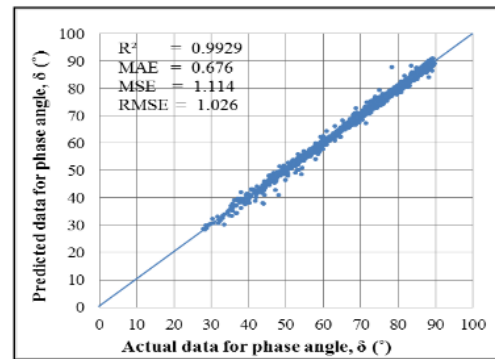

**Figure 8** Graph of predicted value against actual value for phase angle,  $\delta$  using radial basis function neural network model

### Result for Radial Basis Function Neural Network

The best results for models that have been developed were obtained from the determination of spread values through trial and error method. Figures 7 show the predicted values against actual values of complex modulus,  $G^*$  while Figure 8 shows the predicted values against actual values of phase angle,  $\delta$  of bitumen filler mastic using radial basis function model. This model is also good in predict the value of the complex modulus,  $G^*$  and phase angle,  $\delta$  as the value of  $R^2$  obtained were approaching 1. The values are 0.9988 and 0.9929 respectively.

The average error between the predicted data and the actual data or MAE value is small which is 868 kPa for the modulus complex,  $G^*$  and  $0.676^\circ$  for the phase angle,  $\delta$  while the MSE for the complex modulus,  $G^*$  and the phase angle,  $\delta$  is  $3.476 \times 10^{12}$  Pa and  $1.114^\circ$ , respectively. The value will be squared to get RMSE of 14421 kPa of the complex modulus,  $G^*$  and  $1.026^\circ$  for the phase angle,  $\delta$ . Figure 7 also shows that the majority of such data is on the line where it is shown that the predicted data is directly proportional to the actual data.

### Statistical Analysis

Based on the analysis, it can be proved that the developed models are able to predict the complex modulus,  $G^*$  and phase angle,  $\delta$  of bitumen filler mastic well. This is shown on Table 3, where the value of  $R^2$  for both model is closer to 1.00. This value indicates that both models have high accuracy in making the prediction.

Comparison between the two models the value of  $R^2$  for radial basis function neural network model is higher than multilayer feed-forward neural network model as the value is almost approaching 1.00. Besides, the MAE, MSE and RMSE of radial basis function neural network model also lower than multilayer feed-forward neural network model. With this reasons, it can be concluded that radial basis function neural network model can predict the complex modulus,  $G^*$  and phase angle,  $\delta$  better than the multilayer feed-forward neural network model because high  $R^2$  value and a small RMSE values shows that the accuracy of the model is very high [18].



**Table 3** Values for  $R^2$ , MAE, MSE and RMSE

	$R^2$	MAE	MSE	RMSE
<u>Complex modulus, <math>G^*</math>:</u>				
Multilayer feed-forward neural network model.				
	0.9956	623856	4.893E+12	1778812
Radial basis function Neural network model				
	0.9968	86425	4.476E+12	1442195
<u>Phase angle, <math>\delta</math>:</u>				
Multilayer feed-forward neural network model.				
	0.9888	0.763	1.864	1.265
Radial basis function Neural network model				
	0.9929	0.676	1.114	1.026

Comparisons have been made with studies performed by Hamim [16] on the study of rheological properties of asphalt mixture using artificial neural network. This study also uses two types of ANN model of neural network namely multi-layer feed-forward neural network and radial basis function to predict dynamic modulus,  $E^*$  and the phase angle,  $\delta$  for asphalt pavement. Results from this study are shown in Table 5.

**Table 4** The Coefficient of Determination Value,  $R^2$ 

Item	$R^2$
<u>Complex modulus, <math>E^*</math></u>	
Multi-Layer Feed-Forward Network	0.9947
Radial Basis Function Network	0.9953
<u>Phase angle, <math>\delta</math></u>	
Multi-Layer Feed-Forward Network	0.9977
Radial Basis Function Network	0.9997

From Table 4, it can be seen that the developed model in this study has a very high accuracy in predicting the value of the complex modulus,  $G^*$  as the average value of  $R^2$  generated is very close to the value of 1.0 compared to the value of  $R^2$  to the dynamic modulus,  $E^*$  generated in Table 5. However, in this study the average  $R^2$  value obtained is low in predicting the value of the phase angle,  $\delta$  compared with the values in Table 4, which is in the range of 0.9888-0.9929. This occurs because the experiments conducted by Hamim [16], complex modulus data that used is in the range of hundred while the complex modulus data developed in this study were within the range of millions. Furthermore,

16

the number of neurons in the hidden layer of the phase angle used in the Hamim's study is 11, while the number of neurons in the hidden layer used in this study is 15. The range of data and no of neurons in the hidden layer are the factors that influence the accuracy of ANN model [19].

In addition, comparisons were also made on the RMSE value obtained from this study and studies that have been conducted by Xiao *et al.* [20]. It was found that RMSE obtained from previous studies in measuring the stiffness behavior of rubberized asphalt concrete mixture of cryogen at a temperature of 5 °C is 0.81 MPa, which is in the range of stiffness values between 0 to 30 MPa.

The RMSE value is 2.7% of the maximum range of the strength of the mixture. While in this study, the average RMSE values obtained for the complex modulus of both models is of 1.61 MPa in the range of stiffness values between 0 to 255.63 MPa and is 0.63% of the maximum range value of the stiffness. From the comparison that has been made, it was found RMSE for this study is lower compared to studies conducted by Xiao *et al.* [20] The lower RMSE value is preferable to developed a model.

#### 4.0 CONCLUSION

In conclusion it was found that the analysis process show that radial basis function neural network model had a better accuracy in the prediction of the complex modulus,  $G^*$  and phase angle,  $\delta$  compared to multilayer feed-forward neural network model. These studies also reinforces the evidence that the neural network model either radial basis function neural network model or multilayer feed-forward neural network model is able to predict the complex modulus,  $G^*$  and phase angle,  $\delta$  for the bitumen filler mastic well and it can be inferred that the neural network models have an excellent potential to replace the existing analytical and empirical models in predicting the rheological properties of bitumen filler mastic.

#### Acknowledgement

This research is fully supported by FRGS grant, (FRGS/1/2014/TK07/JPP/03/1). The authors fully acknowledged Ministry of Higher Education (MOHE) and Universiti Kebangsaan Malaysia for the approved fund which makes this important research viable and effective.

#### References

- [1] Morse, A. A. & Green, R. L. 2009. Pavement Design and Rehabilitation. Dlm. Brackebrough, R. (ed.). Highway. 223-237. United State: McGraw-Hill.



- [2] Anderson, D. A. 1987. Guidelines for Use of Dust in Hot-Mix Asphalt Concrete Mixtures. *Journal of the Association of Asphalt Paving Technologists*. 56: 492-516.
- [3] Airey, G. D. 1997. Rheological Characteristics of Polymer Modified and Aged Bitumens. Tesis Ph.D. Jabatan Kejuruteraan Awam, Universiti Nottingham, United Kingdom.
- [4] Zeghal, M. 2008. Visco-elastic Portrayal of Bituminous Materials: Artificial Neural Network Approach. *Proceedings of GeoCongress*. New Orleans, Louisiana, 9-32 Mac.
- [5] Hagan, M. T., Demuth, H. B. & Beale, M. H. 1996. *Neural Network Design*. PWS Publishing.
- [6] Thube, D. T. 2012. Artificial Neural Network (ANN) based Pavement Deterioration Models for Low Volume Roads in India. *International Journal of Pavement Research and Technology*. 5(2): 115-120.
- [7] Abo-hashema, M. 2009. Artificial Neural Network Approach for Overlay Design of Flexible Pavements. *The International Arab Journal of Information Technology*. 6(2): 207-212.
- [8] Martínez, F. & Angelone, S. 2009. The Estimation of the Dynamic Modulus of Asphalt Mixtures Using Artificial Neural Networks. Road Laboratory, School of Engineering, University of Rosario Argentina.
- [9] Hassan, H. F. 2010. Artificial Neural Network Technique for Rainfall Forecasting Applied to Alexandria, Egypt. Tesis Master, Jabatan Kejuruteraan Awam & Struktur, Universiti Kebangsaan Malaysia.
- [10] Beale, M. H., Hagan, M. T. & Demuth, H. B. 2012. *Neural Network Toolbox™ User's Guide*. Natick: The MathWorks, Inc.
- [11] Svozil, D., Vladimir KvasniEka, JiE Pospichal 1997. Introduction to Multi-layer Feed-forward Neural Networks. *Chemometrics and Intelligent Laboratory Systems*. 39: 43-62.
- [12] Hornik, K., Stinchcombe, M. & White, H. 1989. Multilayer Feedforward Networks are Universal Approximators. *Neural Networks*. 2: 359-366.
- [13] Salfan, M., Tiğdemir, M. & Kardeşin, M. 2002. Artificial Neural Network Application for Flexible Pavement Thickness Modeling. *Turkish Journal Engineering & Environmental Sciences*. 26: 243-248.
- [14] Yu, B., He, X. 2006. Training Radial Basis Function Networks with Differential Evolution. *Proceedings of IEEE International Conference on Granular Computing*, Atlanta, GA, US. 369-372.
- [15] Tuba Kurban and Erkan Beşdok 2009. A Comparison of RBF Neural Network Training Algorithms for Inertial Sensor Based Terrain Classification. *Journal of Sensors*. 9: 6312-6329.
- [16] Hamim. 2009. Ramalan Ciri-ciri Reologi Campuran Berasphalt Menggunakan Rangkaian Saraf Tiruan. Tesis Master, Jabatan Kejuruteraan Awam dan Struktur, Universiti Kebangsaan Malaysia.
- [17] Chih Liao, Jian-Shiuh Chen, Gordon Airey and Shi-Jing Wang. 2014. Rheological Behavior of Bitumen Mixed with Trinidad Lake Asphalt. *Construction and Building Materials*. 8: 361-367.
- [18] Sobhani, J., Najimi, M., Pourkhorshidi, A. R., & Parhizkar, T. 2010. Prediction of the Compressive Strength of No-Slump Concrete: A Comparative Study of Regression, Neural Network and ANFIS Models. *Construction and Building Materials*. 24(5): 709-718.
- [19] Tiwari, K. C. 2001. Neural Network Parameter Affecting Image Classification. *Journal of Defense Science*. 51: 263-270.
- [20] Xiao, F. & Amirhanian, S. N. 2009. Artificial Neural Network Approach to Estimating Stiffness Behavior of Rubberized Asphalt Concrete Containing Reclaimed Asphalt Pavement. *Journal of Transportation Engineering*. 135(8): 580-589.

# PREDICTING THE RHEOLOGICAL PROPERTIES

---

## ORIGINALITY REPORT

---

26%

SIMILARITY INDEX

%

INTERNET SOURCES

26%

PUBLICATIONS

%

STUDENT PAPERS

---

## PRIMARY SOURCES

---

1

RILEM Bookseries, 2016.

Publication

2%

---

2

Lin, G.F.. "A non-linear rainfall-runoff model using radial basis function network", Journal of Hydrology, 20040420

Publication

1%

---

3

R. Harikumar, B. Vinoth kumar. "Performance analysis of neural networks for classification of medical images with wavelets as a feature extractor", International Journal of Imaging Systems and Technology, 2015

Publication

1%

---

4

IFIP Advances in Information and Communication Technology, 2015.

Publication

1%

---

5

Nur Izzi Md. Yusoff, Montgomery T. Shaw, Gordon D. Airey. "Modelling the linear viscoelastic rheological properties of bituminous binders", Construction and Building Materials, 2011

Publication

1%

---

6

Min-Chih Liao, Jian-Shiuh Chen, Ko-Wan Tsou. "Fatigue Characteristics of Bitumen-Filler Mastics and Asphalt Mixtures", Journal of Materials in Civil Engineering, 2012

Publication

---

1%

7

I. Tlhabadira, I. A. Daniyan, R. Machaka, C. Machio, L. Masu, L. R. VanStaden. "Modelling and optimization of surface roughness during AISI P20 milling process using Taguchi method", The International Journal of Advanced Manufacturing Technology, 2019

Publication

---

1%

8

Hosein Naderpour, Kohei Nagai, Mohammad Haji, Masoomah Mirrashid. "Adaptive neuro-fuzzy inference modelling and sensitivity analysis for capacity estimation of fiber reinforced polymer-strengthened circular reinforced concrete columns", Expert Systems, 2019

Publication

---

1%

9

Dragan D. Stamenkovic, Vladimir M. Popovic. "Warranty optimisation based on the prediction of costs to the manufacturer using neural network model and Monte Carlo simulation", International Journal of Systems Science, 2013

Publication

---

1%

Ivica Androjić, Ivan Marović. "Development of

10 artificial neural network and multiple linear regression models in the prediction process of the hot mix asphalt properties", Canadian Journal of Civil Engineering, 2017 1%

Publication

---

11 Kavita, Navin Rajpal. "Comparative analysis of feed forward and radial basis function neural networks for the reconstruction of noisy curves", 2014 International Conference on Reliability Optimization and Information Technology (ICROIT), 2014 1%

Publication

---

12 "13th International Conference on Theory and Application of Fuzzy Systems and Soft Computing — ICAFS-2018", Springer Science and Business Media LLC, 2019 1%

Publication

---

13 Kurban, Tuba, and Erkan BeÅdok. "A Comparison of RBF Neural Network Training Algorithms for Inertial Sensor Based Terrain Classification", Sensors, 2009. 1%

Publication

---

14 "Recent Advances in Computer Science and Information Engineering", Springer Science and Business Media LLC, 2012 1%

Publication

---

15 Shahriar Najafi, Gerardo W. Flintsch,



Seyedmeysam Khaleghian. "Pavement friction management – artificial neural network approach", International Journal of Pavement Engineering, 2016

Publication

1%

16

N. Leema, H. Khanna Nehemiah, A. Kannan. "Quantum-Behaved Particle Swarm Optimization Based Radial Basis Function Network for Classification of Clinical Datasets", International Journal of Operations Research and Information Systems, 2018

Publication

1%

17

Semet Çelik, Özcan Tan. "Determination of preconsolidation pressure with artificial neural network", Civil Engineering and Environmental Systems, 2005

Publication

1%

18

"The performance of bitumen mastics with the addition of fly ash", Bituminous Mixtures and Pavements VI, 2015.

Publication

1%

19

Amir Sharif Ahmadian. "Numerical Modeling and Simulation", Elsevier BV, 2016

Publication

1%

20

Huaicheng Chen, Chunxiang Qian, Chengyao Liang, Wence Kang. "An approach for predicting the compressive strength of cement-based

<1%

materials exposed to sulfate attack", PLOS ONE, 2018

Publication

---

21

Lauro Ojeda, Johann Borenstein, Gary Witus, Robert Karlsen. "Terrain characterization and classification with a mobile robot", Journal of Field Robotics, 2006

Publication

---

<1%

22

Alessandra Bianchini. "Prediction of Pavement Performance through Neuro-Fuzzy Reasoning : Prediction of pavement performance through neuro-fuzzy reasoning", Computer-Aided Civil and Infrastructure Engineering, 01/2010

Publication

---

<1%

23

GholamAli Shafabakhsh, Mohsen Talebsafa, Mana Motamedi, Saber Kie Badroodi. "Analytical evaluation of load movement on flexible pavement and selection of optimum neural network algorithm", KSCE Journal of Civil Engineering, 2014

Publication

---

<1%

24

Yu Liu, Zhanping You, Qingli Dai, Julian Mills-Beale. "Review of advances in understanding impacts of mix composition characteristics on asphalt concrete (AC) mechanics", International Journal of Pavement Engineering, 2011

Publication

---

<1%

25 Song Xu, Wei Huang, Fuming Cai, Heyao Huang, Changbin Hu. "Evaluation of properties of Trinidad Lake Asphalt and SBS-modified petroleum asphalt", Petroleum Science and Technology, 2019

Publication

<1%

---

26 Lee Jun. "Application of the BP Neural Network in the Checking and Controlling Emission of Vehicle Engines", Advances in Soft Computing, 2007

Publication

<1%

---

27 Christiane Raab, James Grenfell, A.O. Abd El Halim, Manfred Norbert Partl. "The influence of age on interlayer shear properties", International Journal of Pavement Engineering, 2014

Publication

<1%

---

28 Dedi Liu. "Impacts of climate change and human activities on surface runoff in the Dongjiang River basin of China", Hydrological Processes, 2010

Publication

<1%

---

29 Ayad Subhy. "Advanced analytical techniques in fatigue and rutting related characterisations of modified bitumen: Literature review", Construction and Building Materials, 2017

Publication

<1%

---

"CIGOS 2019, Innovation for Sustainable

30

Infrastructure", Springer Science and Business Media LLC, 2020

Publication

<1%

31

Kezhen Yan, Man Zhang, Lingyun You, Shenghua Wu, Hongyan Ji. "Performance and optimization of castor beans-based bio-asphalt and European rock-asphalt modified asphalt binder", Construction and Building Materials, 2020

Publication

<1%

32

Kang, F., J. J. Li, and H. Zhou. "Artificial Neural Network Model for Evaluating Gravelly Soils Liquefaction Using Shear Wave Velocity", International Efforts in Lifeline Earthquake Engineering, 2013.

Publication

<1%

33

Fatai Adesina. "Comparative Study of Gaussian Mixture Model and Radial Basis Function for Voice Recognition", International Journal of Advanced Computer Science and Applications, 2010

Publication

<1%

34

Ali Sarosh, Dong Yun-Feng. "The GA-ANN expert system for mass-model classification of TSTO surrogates", Aerospace Science and Technology, 2016

Publication

<1%



35

González, E. "Use of artificial intelligence in Soil compaction modeling", Advances in Unsaturated Soils, 2013.

Publication

---

<1%

36

Andrea Simone, Francesco Mazzotta, Shahin Eskandarsefat, Cesare Sangiorgi, Valeria Vignali, Claudio Lantieri, Giulio Dondi. "Experimental application of waste glass powder filler in recycled dense-graded asphalt mixtures", Road Materials and Pavement Design, 2017

Publication

---

<1%

37

Mehmet Saltan, Volkan Emre Uz, Bekir Aktas. "Artificial neural networks–based backcalculation of the structural properties of a typical flexible pavement", Neural Computing and Applications, 2012

Publication

---

<1%

38

Feipeng Xiao, Bradley J. Putman, Serji N. Amirkhanian. "Viscosity prediction of CRM binders using artificial neural network approach", International Journal of Pavement Engineering, 2011

Publication

---

<1%

39

A. K. M. Aminul Islam, Nurina Anuar, Zahira Yaakob, Mohamad Osman. " Improving Plant Growth and Yield of Jatropha ( L.) Through Apical Bud Pinching ", International Journal of

<1%

## Fruit Science, 2010

Publication

---

40

"10th International Conference on Robotics, Vision, Signal Processing and Power Applications", Springer Science and Business Media LLC, 2019

Publication

---

41

Ch. Sanjeev Kumar Dash, Ajit Kumar Behera, Satchidananda Dehuri, Sung-Bae Cho. "Radial basis function neural networks: a topical state-of-the-art survey", Open Computer Science, 2016

Publication

---

42

Hasan Ziari, Amir Amini, Ahmad Goli, Danial Mirzaiyan. "Predicting rutting performance of carbon nano tube (CNT) asphalt binders using regression models and neural networks", Construction and Building Materials, 2018

Publication

---

43

Lean Yu, Shouyang Wang, Kin Keung Lai. "Foreign-Exchange-Rate Forecasting With Artificial Neural Networks", Springer Science and Business Media LLC, 2007

Publication

---

44

Fatih Üneş, Mustafa Demirci, Bestami Taşar, Yunus Kaya, Hakan Varçin. "Estimating Dam Reservoir Level Fluctuations Using Data-Driven

<1%

<1%

<1%

<1%

<1%

# Techniques", Polish Journal of Environmental Studies, 2019

Publication

---

45 Brad M. Hopkins, Saied Taheri. "Broken Rail Prediction and Detection Using Wavelets and Artificial Neural Networks", 2011 Joint Rail Conference, 2011

Publication

---

46 Punam Bedi, Harmeet Kaur, Bhavna Gupta. "Trust-based access control for collaborative systems", Journal of Experimental & Theoretical Artificial Intelligence, 2013

Publication

---

47 "Intelligent and Soft Computing in Infrastructure Systems Engineering", Springer Science and Business Media LLC, 2009

Publication

---

48 Feipeng Xiao, Serji N. Amirkhanian. "Artificial Neural Network Approach to Estimating Stiffness Behavior of Rubberized Asphalt Concrete Containing Reclaimed Asphalt Pavement", Journal of Transportation Engineering, 2009

Publication

---

49 Daehyon Kim. " Performance comparison of neural network models: backpropagation . fuzzy artmap ", International Journal of Computer

## Mathematics, 2001

Publication

---

50

"Advances in Neural Networks – ISNN 2013", Springer Science and Business Media LLC, 2013

Publication

---

<1%

51

Rezqallah H. Ramadhan, Hamad I. Al-Abdul Wahhab. "Temperature variation of flexible and rigid pavements in Eastern Saudi Arabia", Building and Environment, 1997

Publication

---

<1%

52

Nikhil Saboo, Rajiv Kumar, Praveen Kumar, Ankit Gupta. "Ranking the Rheological Response of SBS- and EVA-Modified Bitumen Using MSCR and LAS Tests", Journal of Materials in Civil Engineering, 2018

Publication

---

<1%

53

Zhang, J.. "Inferential estimation of polymer quality using bootstrap aggregated neural networks", Neural Networks, 199907

Publication

---

<1%

54

G. D. Airey, T. M. Singleton, A. C. Collop. "Properties of Polymer Modified Bitumen after Rubber-Bitumen Interaction", Journal of Materials in Civil Engineering, 2002

Publication

---

<1%

Shafabakhsh, G.H., O. Jafari Ani, and M.



55

Talebsafa. "Artificial neural network modeling (ANN) for predicting rutting performance of nano-modified hot-mix asphalt mixtures containing steel slag aggregates", Construction and Building Materials, 2015.

Publication

---

56

Dharamveer Singh, Musharraf Zaman, Sesh Commuri. "Artificial Neural Network Modeling for Dynamic Modulus of Hot Mix Asphalt Using Aggregate Shape Properties", Journal of Materials in Civil Engineering, 2013

Publication

---

57

"EC2ND 2005", Springer Science and Business Media LLC, 2006

Publication

---

58

Min-Chih Liao, Jian-Shiuh Chen, Gordon D. Airey, Shi-Jing Wang. "Rheological behavior of bitumen mixed with Trinidad lake asphalt", Construction and Building Materials, 2014

Publication

---

59

Y. M. El-Sayed, S. I. Islam. "Comparison of non-kinetic and kinetic approaches to individualization of gentamicin dosage", European Journal of Clinical Pharmacology, 1990

Publication

---

60

Priya Shirley Muller, M. Nirmala. "Diagnosis of

&lt;1%

&lt;1%

&lt;1%

&lt;1%

&lt;1%

Gestational Diabetes Mellitus using Radial Basis function", 2016 Online International Conference on Green Engineering and Technologies (IC-GET), 2016

Publication

<1%

61

Ming-Huwi Horng, Yun-Xiang Lee, Ming-Chi Lee, Ren-Jean Liou. "Chapter 7 Firefly Meta-Heuristic Algorithm for Training the Radial Basis Function Network for Data Classification and Disease Diagnosis", IntechOpen, 2012

Publication

<1%

62

"Advances in Intelligent Computing", Springer Science and Business Media LLC, 2005

Publication

<1%

63

Lu Yingwei, N. Sundararajan, P. Saratchandran. "Performance evaluation of a sequential minimal radial basis function (RBF) neural network learning algorithm", IEEE Transactions on Neural Networks, 1998

Publication

<1%

64

Renewable Energy in the Service of Mankind Vol II, 2016.

Publication

<1%

Exclude quotes

Off

Exclude matches

Off

Exclude bibliography

Off





# Jurnal Teknologi (Sciences and Engineering)

# 17

H Index

<b>Country</b>	Malaysia - <a href="#">SIR Ranking of Malaysia</a>
<b>Subject Area and Category</b>	Engineering Engineering (miscellaneous)
<b>Publisher</b>	Penerbit Universiti Teknologi Malaysia
<b>Publication type</b>	Journals
<b>ISSN</b>	21803722, 01279696
<b>Coverage</b>	2010-ongoing

**Scope** Jurnal Teknologi (Sciences & Engineering) is an international research journal and invites contributions of original and novel fundamental research. The journal aims to provide an international forum for the presentation of original fundamental research, interpretative reviews and discussion of new developments in in the area of Mathematics, Natural Sciences and Applied Mathematics and Natural Sciences. Papers which describe novel theory and its application to practice are welcome, as are those which illustrate the transfer of multi-disciplinary techniques from other disciplines. Reports of carefully executed experimental work, which is soundly interpreted are also welcome. The overall focus is on original and rigorous research results which have generic significance. Jurnal Teknologi (Sciences & Engineering) invites manuscripts based on original research in any area of Mathematics, Natural Sciences (Biological Sciences, Physical Sciences: Physics, Chemistry, Astronomy, Earth Science) and Applied Mathematics and Natural Sciences (Building Physics, Mechanical Engineering, Chemical Engineering, Civil Engineering, Material Science, Bioechnology, Medical Engineering). Jurnal Teknologi (Sciences & Engineering) does not limit itself to a single perspective or approach, but seeks to represent the diversity of the aforementioned field. Comments and Proposals: Jurnal Teknologi (Sciences & Engineering) is interested in receiving comments/feedback on this and our other journals and welcome publication proposals for books, electronic products, new journals and co-operation for existing journals.

- [Homepage](#)
- [How to publish in this journal](#)
- [Contact](#)
- [Join the conversation about this journal](#)

## Publish with IEEE OJEMB

services from IEEE Engineering in Medicine & Biology for articles in biomedicine including

[ojemb.embs.org](http://ojemb.embs.org)

OPEN

Quartiles





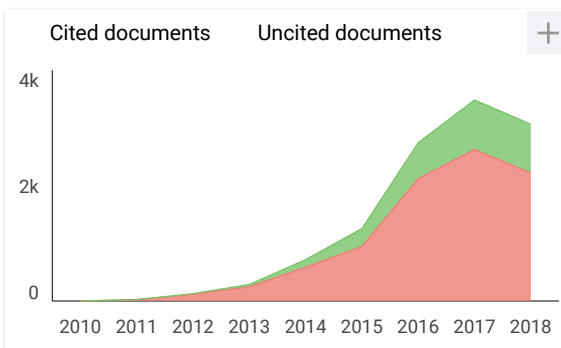
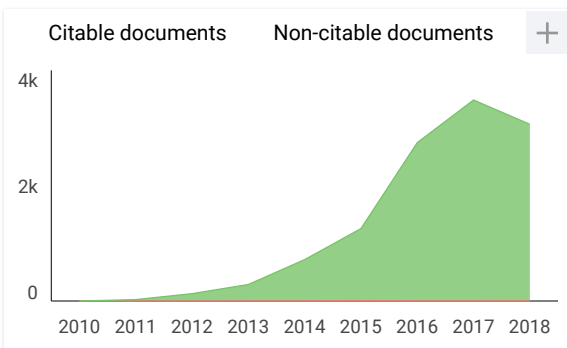
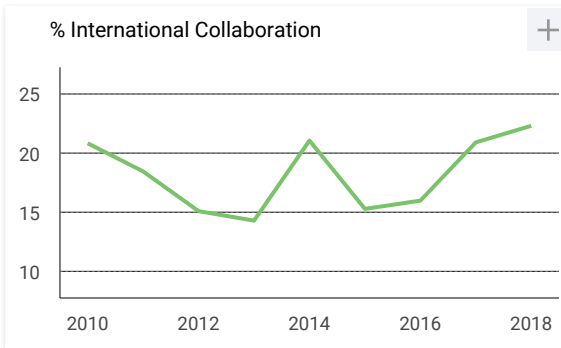
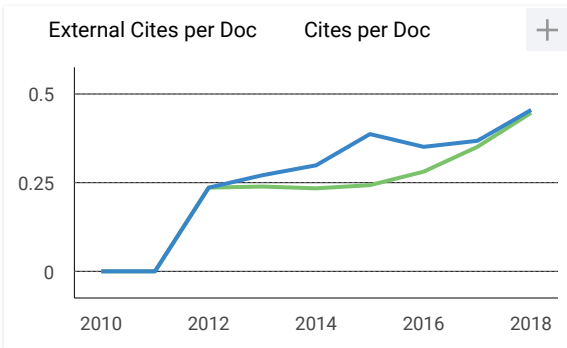
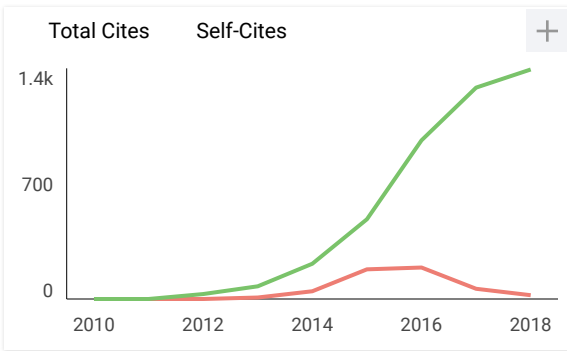
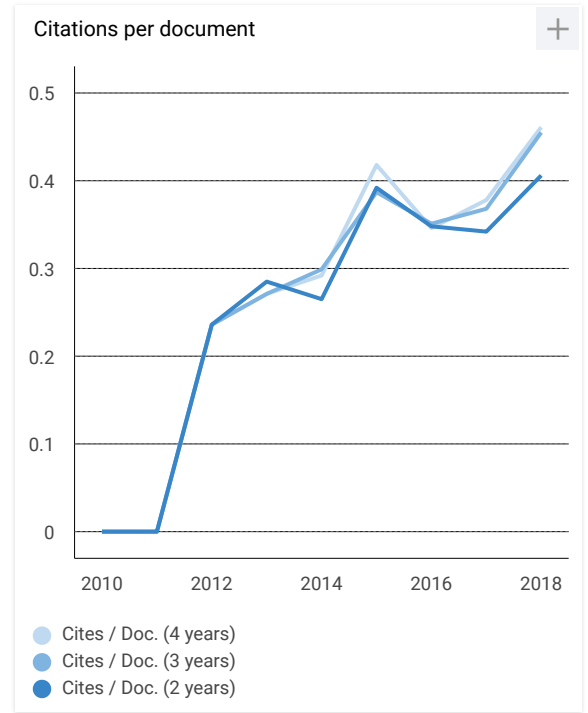
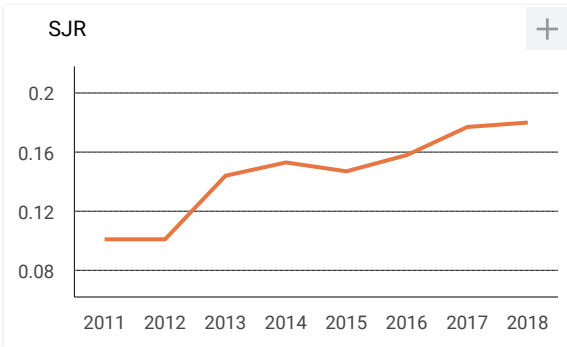
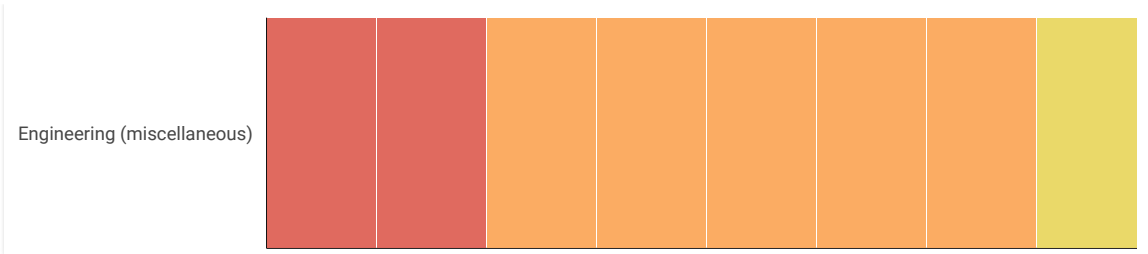

Show this widget in your own website

Just copy the code below and paste within your html code:

```
<a href="https://www.scimaç
```

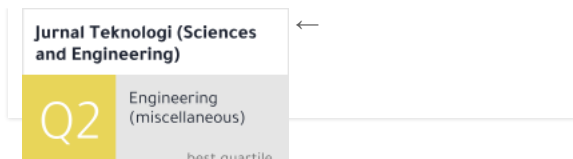

## Publish with IEEE OJEMB

services from IEEE Engineering in Medicine & Biology for articles in biomedicine including

[ojemb.embs.org](http://ojemb.embs.org)

OPEN

### B **Bayu ardiansah** 5 months ago

Jurnal Teknologi provides online submission to every manuscript.

All activities should be done through online. After submission, you will get notification. Once submitted (during review process), authors will not be able to retract the paper (may be this is ethical), and not allowed to submit manuscript to other journals until review process has been done (got notification of acceptance/rejection/revision).

In my case (<https://jurnalteknologi.utm.my/index.php/jurnalteknologi/article/view/13243>), all process need about 5 months waiting. And it no problems.

Probably, 1 month is very short to wait. Ans note that, this is journal from scientific community (by UTM), non profit organization, so they will do carefully, and may be, need longer review process.. Hope this explanation help.

reply

### S **Susilawati** 6 months ago

We submitted the manuscript on Jurnal Teknologi, however, after 1 month waiting, we did not get any notification. So, we withdraw the manuscript and send it to another journal. However, that another journal found that our similarity index was 97% since Jurnal Teknologi save our work on their Turnitin database as student paper of UTM Repository...What??? We are not even students from UTM!! So, another journal rejected our paper due to that occasion, they suggested us to remove our paper first from UTM database. However, Jurnal Teknologi does not want to delete it (maybe they forget the Turnitin ID of checking), even when we ask for the ID, and the funny things that UTM Turnitin operator also ask us to request the ID from Jurnal Teknologi UTM, still Jurnal Teknologi does not want to give the ID. We just want to get the ID and remove it!! It seems like we need to paraphrase everything.....Therefore I report this here, so anyone who wants to submit to Jurnal Teknologi can consider my experience, and ask the editor first not to save the manuscript to their Turnitin Database.

reply



**A Razali** 1 month ago

Thank you for sharing the tips.



**Melanie Ortiz** 1 month ago

SCImago Team

Dear Razali, thanks for your participation! Best Regards, SCImago Team

**B Bayu ardiansah** 5 months ago

Jurnal Teknologi provides online submission to every manuscript.

All activities should be done through online. After submission, you will get notification. Once submitted (during review process), authors will not be able to retract the paper (may be this is ethical), and not allowed to submit manuscript to other journals until review process has been done (got notification of acceptance/rejection/revision).

In my case (<https://jurnalteknologi.utm.my/index.php/jurnalteknologi/article/view/13243>), all process need about 5 months waiting. And it no problems.

Probably, 1 month is very short to wait. Ans note that, this is journal from scientific community (by UTM), non provit organization, so they will do carefully, and may be, need longer review process..

Hope this explanation help.

#### Leave a comment

Name

Email

(will not be published)

I'm not a robot

reCAPTCHA  
[Privacy](#) - [Terms](#)

Submit

The users of Scimago Journal & Country Rank have the possibility to dialogue through comments linked to a specific journal. The purpose is to have a forum in which general doubts about the processes of publication in the journal, experiences and other issues derived from the publication of papers are resolved. For topics on particular articles, maintain the dialogue through the usual channels with your editor.

Developed by:



Powered by:



Follow us on @ScimagoJR

Scimago Lab, Copyright 2007-2019. Data Source: Scopus®

EST MODUS IN REBUS

Horatio (Satire 1,1,106)