

# LAMPIRAN

## KOESIONER ANGKET

Responden yang terhormat,

Saya Desi Avilia Sari mahasiswa Program Studi Ekonomi Syariah Fakultas Agama Islam Universitas Muhammadiyah Yogyakarta. Sedang melakukan analisis tentang **“Pengaruh Label Halal, Harga Dan Promosi Terhadap Keputusan Pembelian Konsumen Pada Produk Mie Samyang (Studi Kasus Pada Mahasiswa Angkatan 2016-2018 Fakultas Agama Islam Universitas Muhammadiyah Yogyakarta)”** yang merupakan sumber utama dari skripsi ini, maka dimohon ketersediaan saudara untuk mengisi pendahuluan koesioner ini secara baik dan benar. Semua informasi ini bersifat rahasia dan dapat digunakan sebagai kepentingan akademis. Atas perhatiannya saya ucapkan terimakasih.

Isilah daftar koesioner berikut, berilah jawaban satu saja dan beri tanda (√) pada jawaban yang telah disediakan :

Nama :

Umur :

Jenis Kelamin :  Laki-laki  
 Perempuan

Konsumsi Mie Samyang : 2/ 3/ 4/ 5.... Kali







Pendapatan : < 500.000  500.000 – 1.000.000  1.000.000 – 2.000.000   
2.000.000-5.00.000  >5.000.000

Jurusan :

Semester :

Berilah tanda (√) pada kolom yang telah disediakan sesuai dengan penilaian anda.

- 1 Sangat Tidak Setuju (STS)
- 2 Tidak Setuju (TS)
- 3 Kurang Setuju (KS)
- 4 Setuju (S)
- 5 Sangat Setuju (SS)

Gambar	No	Label halal (X1)	Penilaian				
		Pernyataan	SS	S	N	TS	STS
	1	Saya selalu memperhatikan gambar tersebut sebelum melakukan pembelian produk mie samyang					
	2	Saya mengetahui letak label halal pada produk mie samyang					
	3	Saya mengetahui label halal yang resmi dari MUI					
	4	Adanya label halal menjadi pertimbangan saya untuk membeli mie samyang					
	5	Karena terdapat label halal mempermudah saya mengetahui mutu produk					
	6	Adanya gambar label halal membantu saya mengidentifikasi produk mie samyang sebelum melakukan pembelian					

No	Harga (X2)	Penilaian				
	Pernyataan	SS	S	N	TS	STS
1	Harga mie samyang terjangkau dengan pendapatan atau uang saku saya					
2	Harga mie samyang sesuai dengan					

	kualitas rasanya					
3	Harga mie samyang sesuai dengan porsi yang disajikan					
4	Harga produk mie samyang bervariasi berdasarkan varian rasa					
5	Harga produk mie samyang sebanding dengan kepuasan yang saya rasakan					
<b>No</b>	<b>Promosi (X3)</b>	<b>Penilaian</b>				
	<b>Pernyataan</b>	<b>SS</b>	<b>S</b>	<b>N</b>	<b>TS</b>	<b>STS</b>
1	Promosi produk mie samyang tersebar secara luas					
2	Saya sering menjumpai atau menemukan iklan mie samyang					
3	Mie samyang sering mempromosikan produknya dengan cara yang berbeda ( <i>challenge</i> mie samyang) di media sosial atau YouTube					
4	Saya tertarik membeli produk mie samyang karena pengaruh promosi produknya yang unik					
5	Mie samyang mempromosikan produknya dengan cara yang menarik sehingga mudah untuk diterima oleh konsumen					

6	Promosi yang dilakukan oleh mie samyang menyasar generasi milenial seperti saya					
---	---	--	--	--	--	--

No	Keputusan pembelian (Y)	Penilaian				
	Pernyataan	SS	S	N	TS	STS
1	Setelah saya memperoleh keyakinan terhadap suatu produk saya memutuskan untuk membeli					
2	Saya berusaha memenuhi kebutuhan makanan dengan produk makanan mie samyang					
3	Saya memutuskan untuk membeli produk makanan mie samyang karena memiliki label halal MUI					
4	Saya merasa aman dan puas mengkonsumsi produk makanan mie samyang					
5	Saya memiliki keinginan untuk membeli kembali produk makanan mie samyang					
6	Saya merekomendasikan produk mie samyang kepada orang lain					

Lampiran Hasil Koesioner

Label Halal						Harga					Promosi						Keputusan Pembelian					
X 1. 1	X 1. 2	X 1. 3	X 1. 4	X 1. 5	X 1. 6	X 2. 1	X 2. 2	X 2. 3	X 2. 4	X 2. 5	X 3. 1	X 3. 2	X 3. 3	X 3. 4	X 3. 5	X 3. 6	Y . 1	Y . 2	Y . 3	Y . 4	Y . 5	Y . 6
2	2	3	3	5	3	4	3	3	3	3	2	2	3	2	3	3	4	5	4	4	5	4
2	2	3	3	5	3	3	3	2	3	3	3	3	3	2	3	2	4	4	4	4	5	4
2	2	2	2	5	2	2	1	2	1	2	2	2	2	2	2	3	4	3	4	4	5	4
2	2	2	3	5	4	3	3	2	3	3	3	3	3	2	3	3	4	3	4	4	5	4
2	3	2	3	5	4	3	3	3	3	4	2	2	3	2	2	2	4	3	4	4	4	4
3	2	4	4	5	4	3	2	2	3	3	3	2	3	2	3	3	4	3	4	4	4	4
2	2	2	3	4	3	2	1	1	2	2	3	2	3	2	2	3	4	3	4	4	4	4
3	3	4	4	4	3	3	2	2	2	2	2	2	2	2	2	2	4	3	4	4	4	5
3	3	3	4	4	4	3	3	2	3	3	3	2	3	2	1	2	4	3	4	4	4	5
2	3	4	4	4	4	3	2	3	3	3	2	2	3	2	3	3	4	3	4	4	4	5
2	3	3	4	4	3	2	3	3	4	4	2	2	3	2	2	2	4	3	4	4	4	5
3	3	4	3	4	3	3	3	3	3	3	2	2	3	2	2	2	4	3	4	4	4	5
2	2	2	1	4	1	2	1	2	1	1	2	2	2	2	2	2	4	3	4	4	4	3
3	2	3	4	4	4	3	3	3	3	4	2	3	3	3	2	3	4	4	4	4	4	3
3	2	3	4	4	4	1	1	2	2	1	3	3	3	3	2	3	4	4	4	4	4	3
3	3	3	4	4	4	2	3	3	3	3	4	3	3	3	3	2	4	4	4	4	5	4
3	3	3	3	4	4	2	3	3	3	2	3	2	3	3	2	3	4	4	5	4	4	3
3	3	3	4	4	4	3	4	3	4	3	3	3	3	3	3	3	4	3	4	4	4	3
3	3	3	4	4	4	3	3	3	3	3	3	3	3	3	3	4	4	3	4	4	4	3
3	3	3	5	4	3	3	3	3	4	4	3	3	3	3	4	4	4	4	4	4	4	4
3	3	3	4	3	4	3	3	3	3	3	3	3	3	3	3	3	4	4	3	4	4	3
3	3	3	4	3	4	3	3	2	3	3	3	3	3	3	3	3	4	3	3	3	3	3
3	3	3	4	3	4	3	3	2	3	3	2	3	3	3	3	3	5	3	4	4	3	3
3	3	3	4	3	4	2	3	3	3	3	2	3	3	3	3	3	3	2	2	3	2	3
3	3	3	4	3	4	3	3	2	3	3	3	3	3	3	3	3	4	4	4	4	4	4
3	3	3	3	3	4	2	3	3	3	3	3	2	3	3	3	3	3	2	3	3	3	3
2	3	2	5	3	5	2	3	3	3	3	3	2	3	3	3	3	4	3	4	4	4	4
2	3	2	5	3	5	1	2	2	1	1	3	2	3	3	3	2	4	4	5	4	4	4
3	3	3	4	4	4	3	3	3	4	4	3	3	3	3	3	3	4	4	5	4	4	5
4	3	2	4	5	4	3	3	3	4	4	3	3	3	3	3	3	4	3	4	3	4	3
3	3	2	4	4	4	3	3	3	4	4	3	2	3	3	3	3	4	3	4	4	4	4
3	3	3	4	4	4	4	3	3	4	3	3	3	3	2	3	3	3	3	4	3	4	3
3	3	3	4	3	4	3	4	3	3	4	3	2	3	2	3	4	4	4	3	3	3	3
3	3	3	4	4	4	4	3	3	3	4	2	3	3	3	3	3	4	4	4	3	3	4
4	3	3	3	3	3	3	4	3	3	4	3	2	3	3	2	3	4	4	4	4	4	3
3	3	3	4	4	4	4	3	3	3	4	3	3	4	3	3	4	3	3	4	4	4	3
3	3	2	4	5	5	3	3	3	4	4	3	3	3	4	4	3	4	3	4	4	4	4

3	2	2	4	3	5	3	4	3	3	3	4	4	4	4	4	5	3	3	4	4	4	4
4	3	2	4	4	3	3	4	4	3	3	3	3	3	4	4	3	4	3	4	3	4	4
3	3	2	4	3	4	4	3	4	3	3	3	3	4	3	4	4	4	3	5	4	4	3
3	4	3	3	4	4	3	3	4	3	3	3	3	3	4	4	5	5	4	4	5	4	
3	3	2	5	4	4	3	3	3	4	3	4	3	4	3	3	3	4	3	3	3	4	3
3	2	2	5	4	5	4	4	3	3	3	2	2	2	2	3	3	4	4	4	3	3	4
3	3	2	5	4	4	3	3	2	3	3	3	3	3	2	3	2	4	4	4	4	4	3
3	3	2	5	4	4	3	3	3	2	3	4	3	4	3	3	3	4	3	3	4	4	3
3	2	3	5	3	4	4	3	3	4	3	4	3	3	3	3	3	3	3	4	4	3	4
3	3	3	4	3	3	4	4	3	3	3	3	3	4	5	3	4	4	3	4	5	4	4
3	3	3	3	4	5	4	3	3	3	3	4	3	4	4	3	3	4	3	3	3	3	3
3	3	3	3	4	5	4	3	3	3	3	4	3	3	3	4	4	4	3	3	3	4	3
3	2	2	2	4	3	2	2	1	2	1	3	3	3	4	4	4	4	3	4	4	4	3
2	3	3	3	4	3	2	2	1	1	2	3	3	4	3	4	4	4	3	4	4	4	3
2	2	2	3	4	2	4	4	3	3	3	4	3	3	3	4	4	4	3	4	4	3	3
1	1	1	2	5	2	3	3	3	3	3	3	3	3	4	4	4	4	3	3	3	3	3
2	1	1	1	4	2	3	3	3	4	3	3	3	3	3	4	4	4	3	3	4	4	4
2	1	2	2	4	1	4	4	3	3	3	3	3	3	2	3	2	3	3	3	3	3	3
2	1	1	2	3	2	3	3	3	4	3	3	2	2	3	2	3	3	3	3	3	3	3
2	1	1	2	3	1	3	4	3	3	4	4	3	4	3	3	3	3	4	4	4	4	3
3	3	3	4	4	4	4	3	3	3	4	3	4	4	4	3	3	3	3	3	3	4	3
2	2	3	3	5	2	2	4	4	3	2	3	2	3	3	3	3	4	3	3	3	3	4
3	2	2	3	4	4	3	3	3	3	3	3	3	3	3	3	3	3	3	4	4	3	3
3	3	3	4	3	4	2	2	2	1	1	3	3	3	3	3	4	4	4	4	4	4	4
3	3	3	3	4	3	4	3	3	4	3	3	3	4	4	3	4	3	3	3	3	3	5
3	3	4	3	3	4	2	4	3	3	4	3	3	3	4	3	3	4	4	4	4	4	4
3	3	3	3	5	4	3	4	3	3	2	4	3	3	3	4	4	3	3	2	3	3	2
2	3	3	3	5	3	4	4	3	3	3	3	3	3	3	4	3	4	3	4	4	4	3
3	3	3	3	4	3	2	4	3	3	3	3	4	3	4	4	3	4	3	3	4	4	4
2	2	3	3	3	3	3	3	3	4	3	4	3	5	3	3	3	4	3	4	4	3	3
2	3	3	4	4	3	3	5	3	3	3	4	3	3	3	4	4	4	2	4	4	4	3
2	2	2	3	3	3	3	5	3	3	3	3	3	3	4	3	3	4	3	4	3	3	3
3	3	3	3	4	4	3	4	3	4	3	3	3	4	4	3	3	4	4	4	4	4	4
3	3	4	3	3	4	3	3	3	3	4	3	4	3	3	3	4	4	3	4	4	3	4
2	3	3	3	4	3	3	3	3	3	3	3	3	4	3	3	3	4	4	4	4	4	3
3	3	2	3	4	3	3	3	3	3	4	3	3	4	4	3	3	3	2	3	3	3	5
2	3	3	3	4	3	3	3	3	4	3	3	3	3	3	3	4	4	3	4	4	4	3
2	3	3	3	4	3	3	4	3	3	2	3	3	3	3	3	3	4	3	4	4	4	4
3	2	2	3	4	2	3	4	3	4	3	3	3	4	3	3	4	4	3	3	4	4	3
3	3	2	2	4	3	3	4	3	3	3	3	3	3	3	4	3	4	3	3	3	3	3
3	3	3	4	3	4	4	4	2	3	3	3	3	3	3	3	4	4	4	4	4	4	4
2	2	1	1	4	2	4	3	3	4	3	1	2	2	1	2	2	3	2	4	4	3	3

3	3	3	2	4	3	3	3	4	3	4	3	3	4	3	4	4	4	3	3	3	3	3
3	3	3	4	3	4	4	4	3	3	3	3	3	4	4	3	4	4	3	3	3	3	3
3	3	3	4	5	4	3	3	3	4	4	2	3	3	3	3	3	4	4	4	4	4	4
2	3	3	3	4	3	3	3	2	3	3	4	3	3	4	4	3	4	4	4	4	4	3
3	3	3	3	3	3	4	4	3	3	3	1	2	2	2	2	2	4	3	4	3	3	3
3	3	3	4	5	4	4	3	3	4	3	1	2	2	2	2	2	3	3	3	3	3	4
2	3	3	3	5	3	2	2	2	1	1	3	2	2	3	3	3	4	4	4	4	3	3
2	3	3	3	4	4	3	4	4	3	3	2	2	3	3	3	3	4	3	4	3	4	3
3	3	3	4	3	3	4	3	4	3	3	3	3	4	4	3	3	5	3	5	4	5	3
3	3	3	4	3	4	4	3	3	3	3	3	3	4	4	3	3	5	3	4	4	4	3
3	3	2	4	3	4	3	4	4	3	3	3	3	4	3	3	3	4	3	4	4	4	4
2	3	3	2	5	3	3	3	3	3	4	3	2	3	3	3	3	3	3	3	3	3	3
2	2	3	3	4	2	3	3	4	3	2	3	3	4	4	4	2	4	3	4	3	4	2
3	3	3	3	5	4	3	3	3	4	4	3	3	4	4	4	2	4	5	4	4	4	4
3	4	4	3	4	3	3	4	3	3	4	4	3	3	4	4	3	4	3	3	4	4	4
3	3	3	3	3	4	4	4	3	3	3	3	3	4	4	3	4	3	3	3	3	3	3
3	3	3	3	4	3	3	3	3	3	2	3	2	2	3	2	3	4	3	4	4	4	4
3	3	2	3	5	3	3	4	3	4	3	3	2	3	3	3	2	4	4	4	4	4	4
1	1	2	2	3	2	2	2	3	3	2	1	2	2	2	2	2	4	3	3	4	3	4
2	1	1	2	4	1	1	1	2	2	2	2	3	3	3	3	3	4	4	4	4	4	3
2	2	2	1	3	1	3	3	4	3	3	2	2	2	1	2	2	3	4	3	4	4	4



## Hasil Olah Data SmartPLS

### 1. Uji Validitas

Tampilan Output Model Pengukuran Uji validitas

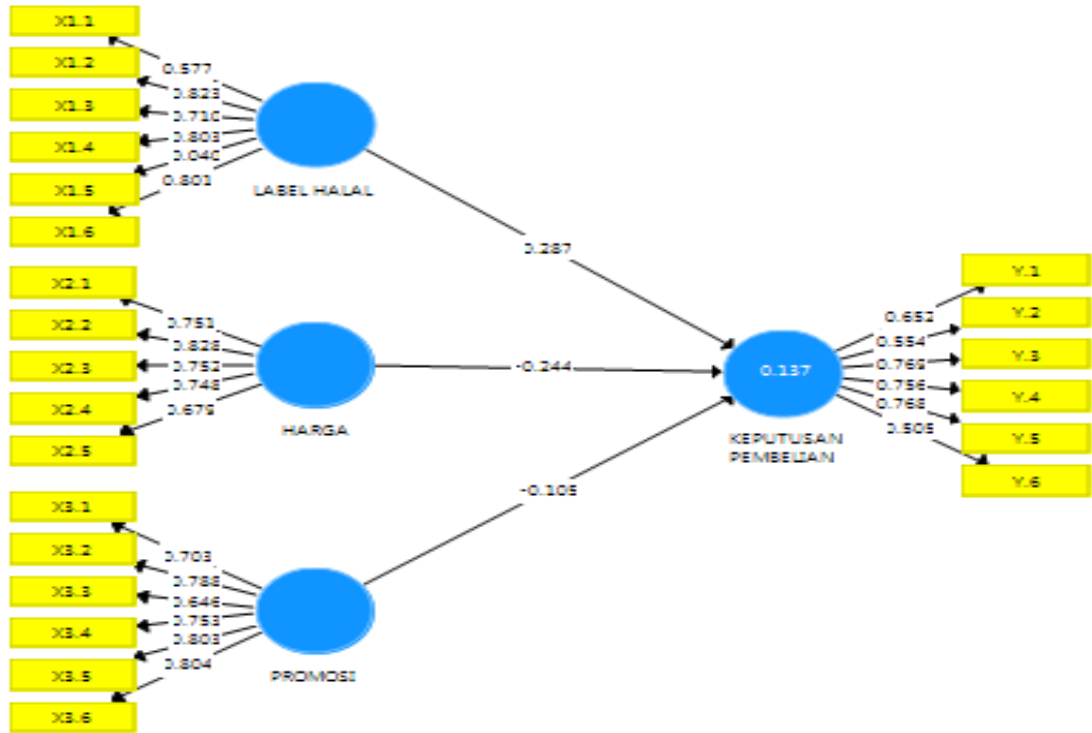

Average Variance Extracted (AVE)

Variabel	Rata-rata Varians Diekstrak (AVE)	Keterangan
Label Halal	0,467	TidakValid
Harga	0,567	Valid
Promosi	0,565	Valid
Keputusan Pembelian	0,457	TidakValid

Sumber : Data Primer yang diolah (2019)

Tampilan Output Model Pengukuran Uji validitas

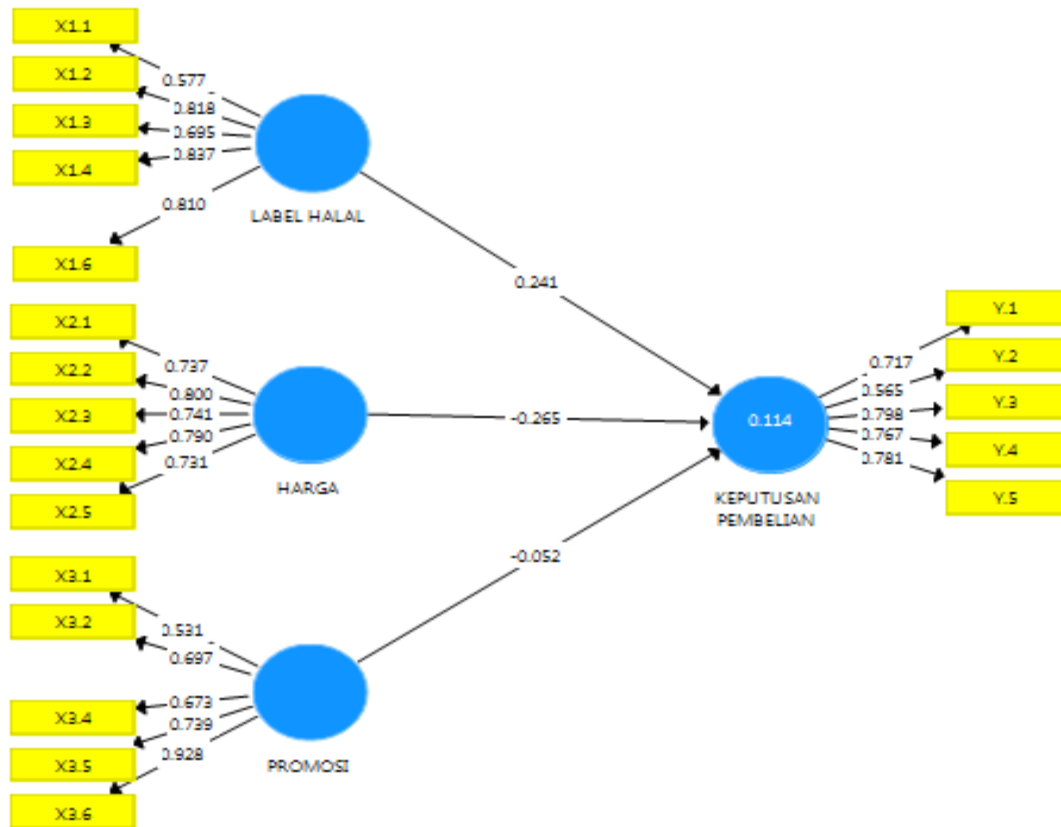

Sumber : Data Primer yang diolah (2019)

. Average Variance Extracted (AVE)

Variabel	Rata-rata Varians Diekstrak (AVE)	Keterangan
Label Halal	0,568	Valid
Harga	0,578	Valid
Promosi	0,526	Valid
Keputusan Pembelian	0,534	Valid

Sumber : Data Primer yang diolah (2019)

## 2. Uji Reliabilitas

Nilai Cronbach's alpha dan Composite Realibility

Variabel	Cronbach's Alpha	Reliabilitas Komposit	Keterangan
Label Halal	0,827	0,866	Reliabel
Harga	0,819	0,872	Reliabel
Promosi	0,837	0,843	Reliabel
Keputusan Pembelian	0,779	0,850	Reliabel

Sumber : Data Primer yang diolah (2019)

### 3. R Square

Hasil R Square (R<sup>2</sup>)

	R Square
Keputusan Pembelian	0,114

Sumber : Data Primer yang diolah (2019)

### 4. Cross-validated Redundancy (Q<sup>2</sup>)

Hasil Cross-validated Redundancy (Q<sup>2</sup>)

	Cross-validated Redundancy (Q <sup>2</sup> )
Keputusan Pembelian	0,038

Sumber : Data Primer yang diolah (2019)

### 5. Path Coefficients

Hasil Path Coefficients

	Sampel	Rata-rata	Standar	T Statistik	P
	Asli (O)	Sampel (M)	Deviasi	(O/STDEV)	Values
			(STDEV)		

Label Halal ->					
Keputusan					
Pembelian	0,241	0,269	0,117	2,053	0,043
Harga ->					
Keputusan					
pembelian	-0,265	-0,309	0,072	3,043	0,000
Promosi ->					
Keputusan					
Pembelian	-0,052	-0,040	0,174	0,300	0,765

### Tabel Presentase Hasil Kuesioner

Table kategori kecendrungan variabel Label Halal (X1)

No	Kelas	Frekuensi	Presentase	Kategori
1	$X > 15,89$	57	57%	Sangat Setuju
2	$12,96 < X \leq 15,89$	25	25%	Setuju
3	$10,03 < X \leq 12,96$	7	7%	Kurang Setuju
4	$7,10 < X \leq 10,03$	7	7%	Tidak Setuju
5	$X \leq 7,10$	4	4%	Sangat Tidak Setuju
	Total	100	100%	

Table kategori kecendrungan variabel harga (X2)

No	Kelas	Frekuensi	Presentase	Kategori
1	$X > 15,65$	60	60%	Sangat Setuju
2	$12,88 < X \leq 15,65$	28	28%	Setuju
3	$10,11 < X \leq 12,88$	2	2%	Kurang Setuju
4	$7,34 < X \leq 10,11$	7	7%	Tidak Setuju
5	$X \leq 7,34$	3	3%	Sangat Tidak Setuju
	Total	100	100%	

Table kategori kecendrungan variabel promosi (X3)

No	Kelas	Frekuensi	Presentase	Kategori
1	$X > 22,45$	1	1%	Sangat Setuju
2	$19,48 < X \leq 22,45$	36	36%	Setuju
3	$16,51 < X \leq 19,48$	34	34%	Kurang Setuju
4	$13,54 < X \leq 16,51$	17	17%	Tidak Setuju
5	$X \leq 13,54$	12	12%	Sangat Tidak Setuju
	Total	100	100%	

Table kategori kecendrungan variabel keputusan pembelian (Y)

No	Kelas	Frekuensi	Presentase	Kategori
1	$X > 23.87$	27	27%	Sangat Setuju
2	$21.62 < X \leq 23.87$	47	47%	Setuju
3	$19.37 < X \leq 21.62$	10	10%	Kurang Setuju
4	$17.12 < X \leq 19.37$	13	13%	Tidak Setuju
5	$X \leq 17.12$	3	3%	Sangat Tidak Setuju
	Total	100	100%	



**PERPUSTAKAAN**  
**UNIVERSITAS MUHAMMADIYAH YOGYAKARTA (UMY)**  
Terakreditasi "A" (Perpustakaan Nasional RI No : 29/1/ee/XII.2014)

---

Perpustakaan Universitas Muhammadiyah Yogyakarta menyatakan bahwa atas nama :

Nama : Desi Avilia Sari  
Prodi/Fakultas : Ekonomi Syariah/Agama Islam  
NIM : 20130730038  
Judul : Pengaruh Label Halal, Harga dan Promosi Terhadap Keputusan Pembelian Konsumen  
Pada Produk Mie Samyang ( Studi Kasus Pada Mahasiswa Angkatan 2016-2018  
Fakultas Agama Islam Universitas Muhammadiyah Yogyakarta)  
Dosen Pembimbing : Safaah Restuning Hayati, Lc, SEI, M

Telah dilakukan tes Turnitin filter 1%, dengan tingkat similaritasnya sebesar **19%**.  
Semoga surat keterangan ini dapat digunakan sebagaimana mestinya.

Mengetahui  
Ka.Ur. Pengolahan dan Layanan

Laela Niswatin, S.I.Pust.

Yogyakarta, 2019-12-16  
yang melaksanakan pengecekan

M. Burhanuddin Irsyadi, S.P.



**UMY** UNIVERSITAS  
MUHAMMADIYAH  
YOGYAKARTA

Unggul & Islami

**FAKULTAS AGAMA ISLAM**

Program Studi Komunikasi & Penyiaran Islam  
Program Studi Pendidikan Agama Islam  
Program Studi Ekonomi Syariah

Nomor : 240/A.2-III/EKSYA-UMY/X/2019  
Lampiran : 1 (satu) bandel proposal  
Hal : Permohonan Ijin Penelitian

Kepada Yth :

**Kepala Tata Usaha Fakultas Agama Islam**  
Universitas Muhammadiyah Yogyakarta  
di Tempat

*Assalamu'alaikum Wr. Wb*

Dengan hormat,

Sehubungan dengan rencana penulisan skripsi sebagai tugas akhir bagi mahasiswa Program Studi Ekonomi Syariah Fakultas Agama Islam Universitas Muhammadiyah Yogyakarta tahun akademik 2019/2020, maka dengan ini kami memohonkan ijin mahasiswa berikut untuk dapat melakukan penelitian di instansi yang Bapak/Ibu pimpin. Surat penelitian ini berlaku sampai tanggal 14 November 2019.

Adapun mahasiswa tersebut adalah:

Nama Mahasiswa	: Desi Avilia Sari
NIM	: 20130730038
Jurusan/Program Studi	: Ekonomi Syariah
Judul Skripsi	: Pengaruh Label Halal, Harga dan Promosi terhadap Keputusan Pembelian Konsumen pada Produk Mie Samyang (Studi Kasus pada Mahasiswa angkatan 2016-2018 Fakultas Agama Islam Universitas Muhammadiyah Yogyakarta)

Demikian permohonan ini kami sampaikan, atas perhatian dan kerjasamanya diucapkan terimakasih.

*Wassalamu'alaikum wr. Wb.*

Yogyakarta, 14 Oktober 2019

Dekan  
Ka. Prodi Jurusan



**Dr. Maesvaroh, M.A.**

NIK. 19741006201504 113 047

**ADDRESS**

Gedung F6 (Siti Walidah) Lt.1 Kampus Terpadu UMY  
Jl. Lingkar Selatan (Brawijaya) Tamantirto,  
Kasihan, Bantul, Yogyakarta 55183

**CONTACT**

Phone : +62 274 387656 Ext 130  
Fax : +62 274 387656  
Email : fai@umy.ac.id

[www.fai.umy.ac.id](http://www.fai.umy.ac.id)





## Curriculum Vitae

### Desi Avilia Sari



#### DATA PRIBADI

Jenis Kelamin : Perempuan  
Tempat/Tanggal Lahir : Jepara, 11 Desember 1995  
Umur : 24 Tahun  
Agama : Islam  
Tinggi/Berat Badan : 164cm/64 Kg  
Alamat : Dk. Duren RT03/03 Tubanan, Kembang, Jepara, Jawa Tengah  
Email : desiavilia.95@gmail.com  
No.Hp : 087733943195

#### PENDIDIKAN

SDN 05 Tubanan, Jepara  
SMP N 1 Kembang, Jepara  
SMA N 1 Kembang, Jepara  
S1 Ekonomi Syariah, Universitas Muhammadiyah Yogyakarta

#### SEMINAR/WORKSHOP/PELATIHAN

2013 Seminar Motivasi Kepenulisan “Ku Ubah Dunia Dengan Menulis  
2013 Seminar Ekonomi Islam  
2015 Pelatihan Persiapan Kerja  
2015 Pelatihan Online Marketing  
2015 Talkshow & Seminar Kewirausahaan  
2015 Seminar Nasional “Reaktualisasi Ekonomi Islam di Indonesia”  
2015 Upgrading Nasional Pemandu LAPENKOP  
2015 Roadshow Sekolah Pasar Modal Syariah  
2016 Pelatihan Perkoperasian Berbasis Syariah

#### KEMAMPUAN

1. Mampu Mengoperasikan MS. Office
2. Mampu Berbicara di Depan Umum
3. Dapat Bekerja Dibawah Tekanan
4. Dapat Bekerja Dalam Tim

#### KEPANITIAAN

2014 Panitia Seminar Islamic Entrepreneurship  
2014 Panitia DIKLATSARKOP

#### ORGANISASI

2014-2016 Pengurus Keuangan Koperasi Mahasiswa UMY