

alat pirolisis tes



| | |
|----------------------------|-----------------------------|
| Analyzed File: | tes alat pirolisis.iam |
| Autodesk Inventor Version: | 2016 (Build 200138000, 138) |
| Creation Date: | 23/07/2019, 4:36 |
| Simulation Author: | Kumala |
| Summary: | |

Project Info (iProperties)

Summary

| | |
|--------|--------|
| Author | Kumala |
|--------|--------|

Project

| | |
|--------------|--------------------|
| Part Number | tes alat pirolisis |
| Designer | Kumala |
| Cost | Rp0 |
| Date Created | 23/07/2019 |

Status

| | |
|---------------|----------------|
| Design Status | WorkInProgress |
|---------------|----------------|

Physical

| | |
|-------------------|--|
| Mass | 20,2715 kg |
| Area | 3003140 mm ² |
| Volume | 5785760 mm ³ |
| Center of Gravity | x=40,9024 mm y=-90,3834 mm z=-30,9308 mm |

Note: Physical values could be different from Physical values used by FEA reported below.

tes pirolisis

General objective and settings:

| | |
|---------------------------------------|------------------|
| Design Objective | Single Point |
| Simulation Type | Static Analysis |
| Last Modification Date | 23/07/2019, 4:35 |
| Detect and Eliminate Rigid Body Modes | No |

| | |
|---|----|
| Separate Stresses Across Contact Surfaces | No |
| Motion Loads Analysis | No |

Mesh settings:

| | |
|--|--------|
| Avg. Element Size (fraction of model diameter) | 0,1 |
| Min. Element Size (fraction of avg. size) | 0,2 |
| Grading Factor | 1,5 |
| Max. Turn Angle | 60 deg |
| Create Curved Mesh Elements | No |
| Use part based measure for Assembly mesh | Yes |

Material(s)

| | | |
|--------------|--|------------------------|
| Name | Steel | |
| General | Mass Density | 7,85 g/cm ³ |
| | Yield Strength | 207 MPa |
| | Ultimate Tensile Strength | 345 MPa |
| Stress | Young's Modulus | 210 GPa |
| | Poisson's Ratio | 0,3 ul |
| | Shear Modulus | 80,7692 GPa |
| Part Name(s) | rangka oke ISO 20x20x2 00000001.ipt ISO 20x20x2 00000002.ipt ISO 20x20x2 00000003.ipt ISO 20x20x2 00000004.ipt ISO 20x20x2 00000005.ipt ISO 20x20x2 00000006.ipt ISO 20x20x2 00000007.ipt ISO 20x20x2 00000008.ipt ISO 20x20x2 00000009.ipt ISO 20x20x2 00000010.ipt ISO 20x20x2 00000011.ipt ISO 20x20x2 00000012.ipt ISO 20x20x2 00000013.ipt ISO 20x20x2 00000014.ipt ISO 20x20x2 00000015.ipt ISO 20x20x2 00000016.ipt ISO 20x20x2 00000017.ipt ISO 20x20x2 00000018.ipt ISO 20x20x2 00000019.ipt ISO 20x20x2 00000020.ipt ISO 20x20x2 00000021.ipt ISO 20x20x2 00000022.ipt ISO 20x20x2 00000023.ipt ISO 20x20x2 00000024.ipt ISO 20x20x2 00000025.ipt ISO 20x20x2 00000026.ipt ISO 20x20x2 00000027.ipt ISO 20x20x2 00000028.ipt ISO 20x20x2 00000029.ipt | |

| | | |
|--------------|--|---------------------|
| | ISO 20x20x2 00000030.ipt ISO 20x20x2 00000031.ipt ISO 20x20x2 00000032.ipt ISO 20x20x2 00000033.ipt | |
| Name | Generic | |
| General | Mass Density | 1 g/cm ³ |
| | Yield Strength | 0 MPa |
| | Ultimate Tensile Strength | 0 MPa |
| Stress | Young's Modulus | 0,0000001 GPa |
| | Poisson's Ratio | 0 ul |
| | Shear Modulus | 0,00000005 GPa |
| Part Name(s) | Skeleton0001 Skeleton0007 | |
| Name | Stainless Steel | |
| General | Mass Density | 8 g/cm ³ |
| | Yield Strength | 250 MPa |
| | Ultimate Tensile Strength | 540 MPa |
| Stress | Young's Modulus | 193 GPa |
| | Poisson's Ratio | 0,3 ul |
| | Shear Modulus | 74,2308 GPa |
| Part Name(s) | reaktor tutup oke pipa utuh reaktor udara kondensor air oke ISO 21.3x2.0 00000031.ipt ISO 21.3x2.0 00000032.ipt ISO 21.3x2.0 00000033.ipt ISO 21.3x2.0 00000034.ipt ISO 21.3x2.0 00000035.ipt | |

Operating conditions

Remote Force:1

| | |
|----------------|--------------|
| Load Type | Remote Force |
| Magnitude | 25,000 N |
| Vector X | 0,000 N |
| Vector Y | -25,000 N |
| Vector Z | 0,000 N |
| Remote Point X | -187,000 mm |
| Remote Point Y | 195,000 mm |
| Remote Point Z | 0,000 mm |

Selected Face(s)

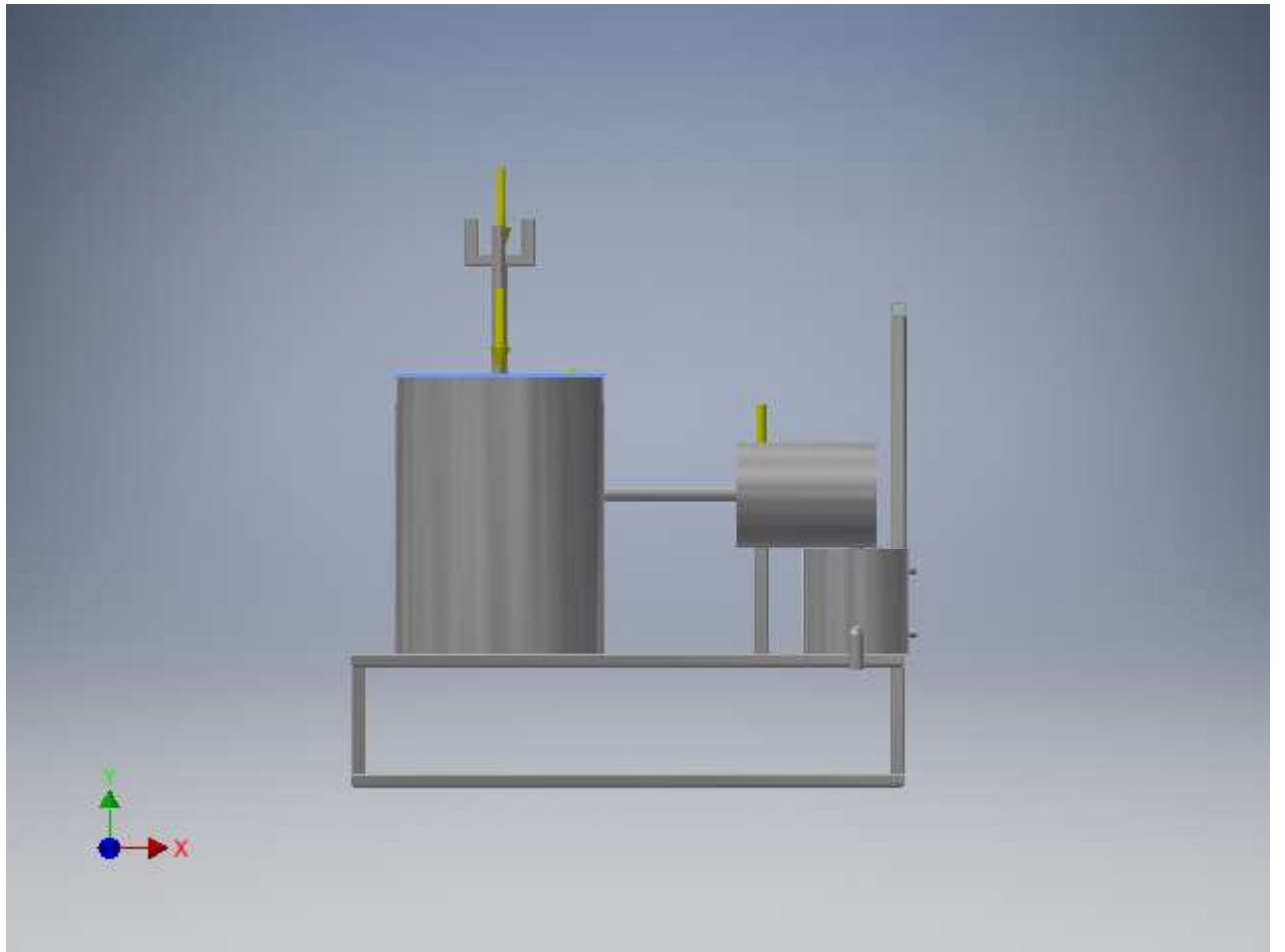

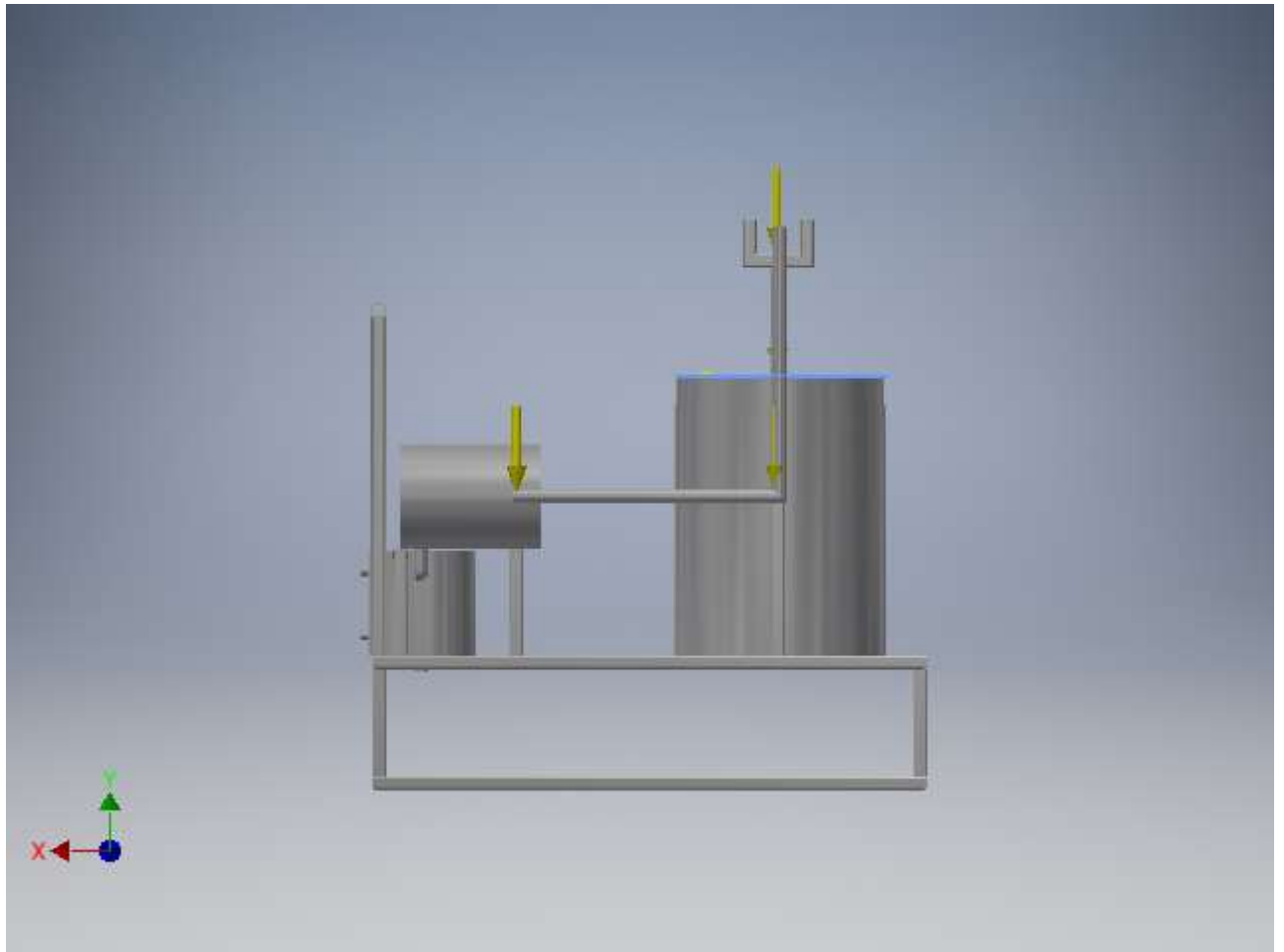

Remote Force:2

| Load Type | Remote Force |
|----------------|--------------|
| Magnitude | 80,000 N |
| Vector X | 0,000 N |
| Vector Y | -80,000 N |
| Vector Z | 0,000 N |
| Remote Point X | -187,000 mm |
| Remote Point Y | -200,000 mm |
| Remote Point Z | 0,000 mm |

Selected Face(s)

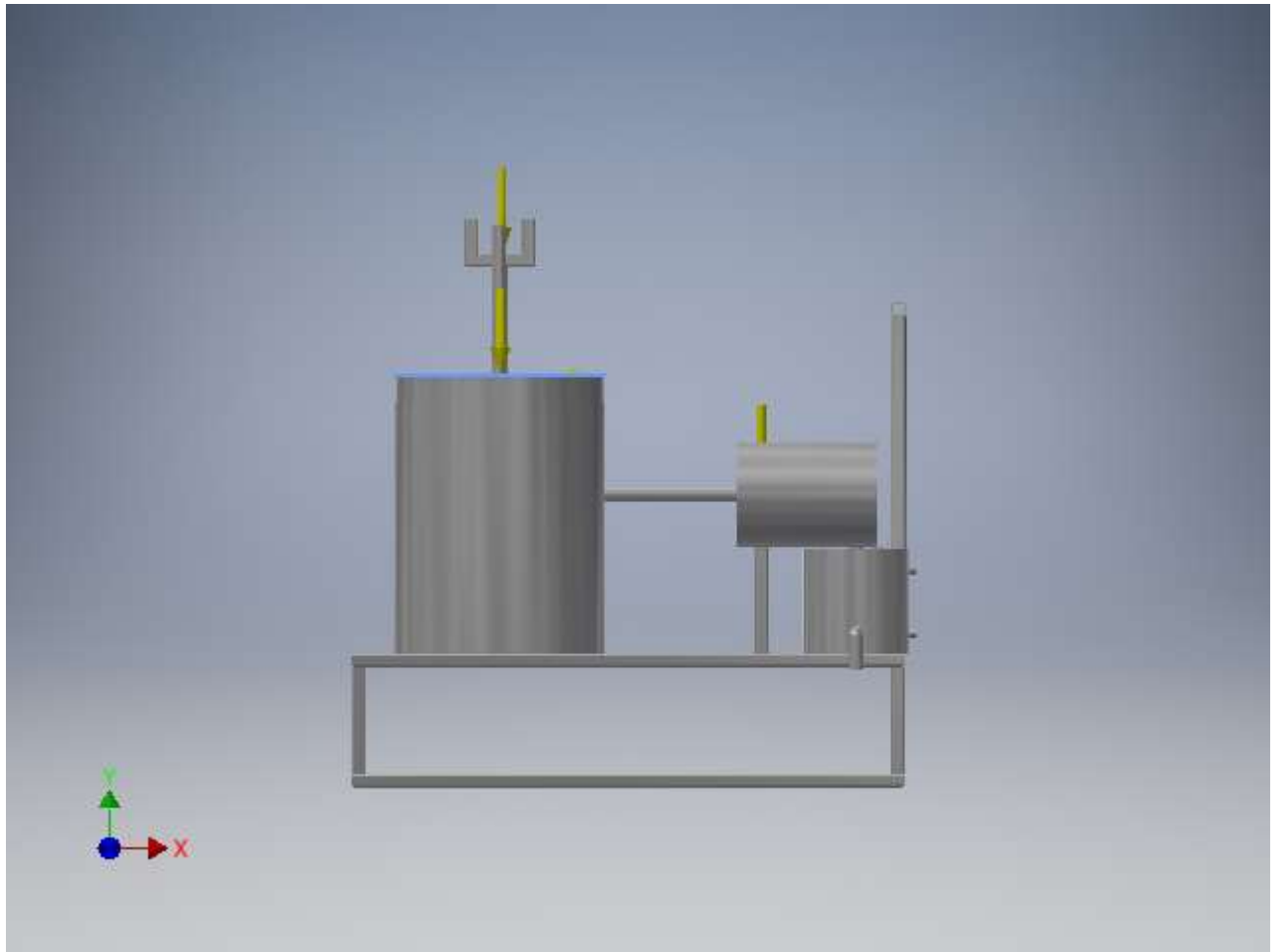

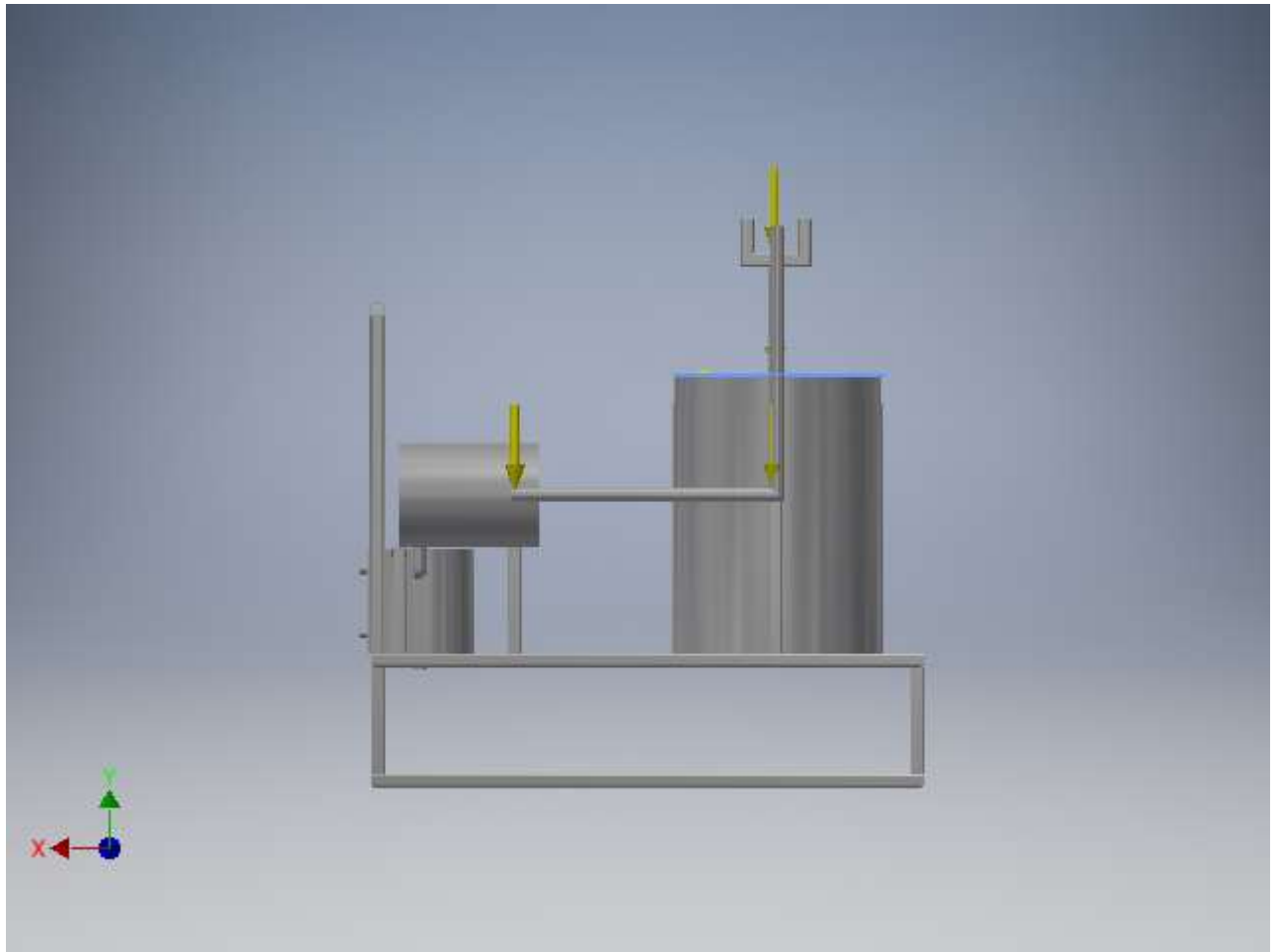

Remote Force:3

| Load Type | Remote Force |
|----------------|--------------|
| Magnitude | 25,000 N |
| Vector X | 0,000 N |
| Vector Y | -25,000 N |
| Vector Z | -0,000 N |
| Remote Point X | -185,000 mm |
| Remote Point Y | 365,000 mm |
| Remote Point Z | -195,000 mm |

Selected Face(s)

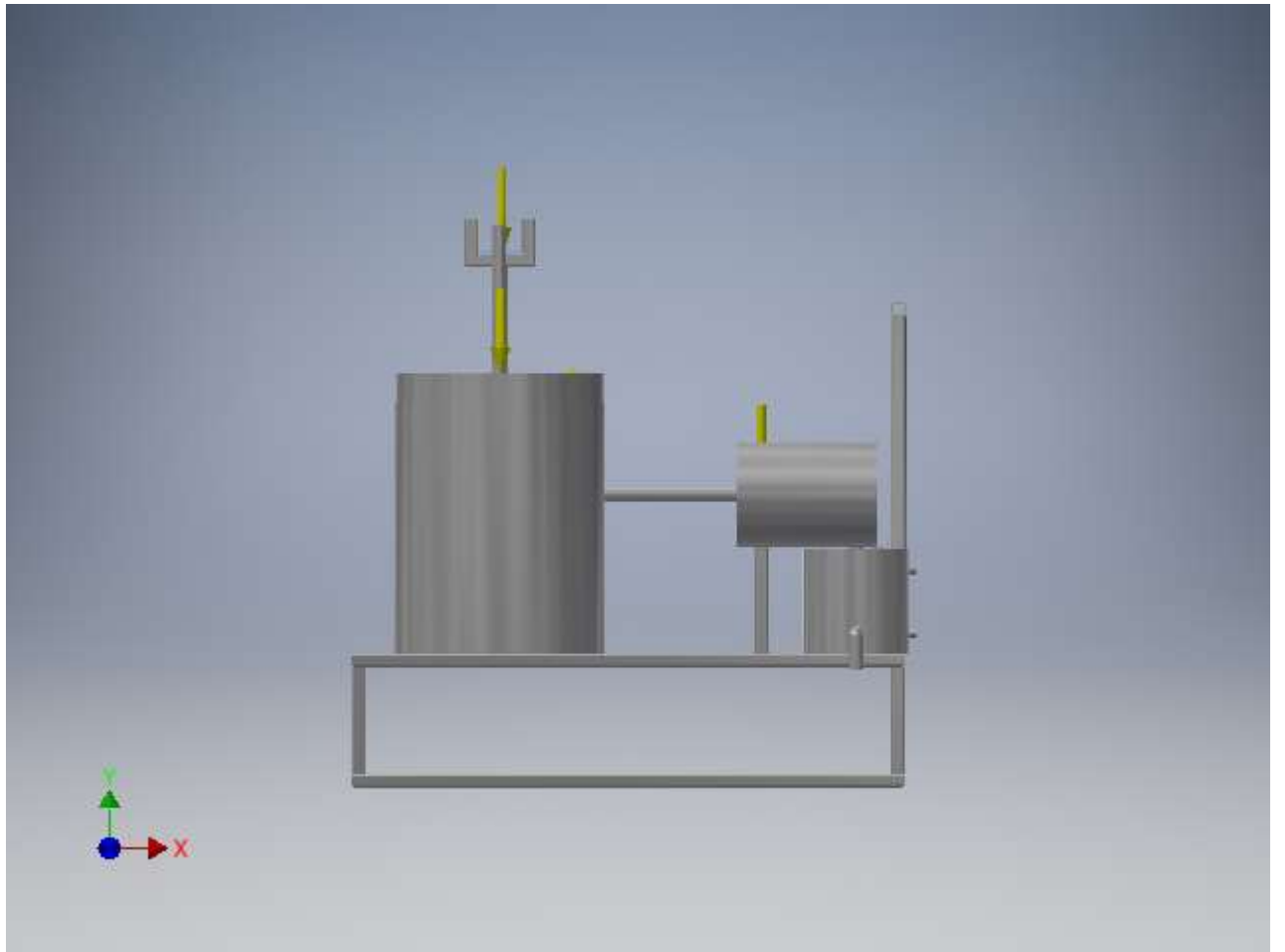

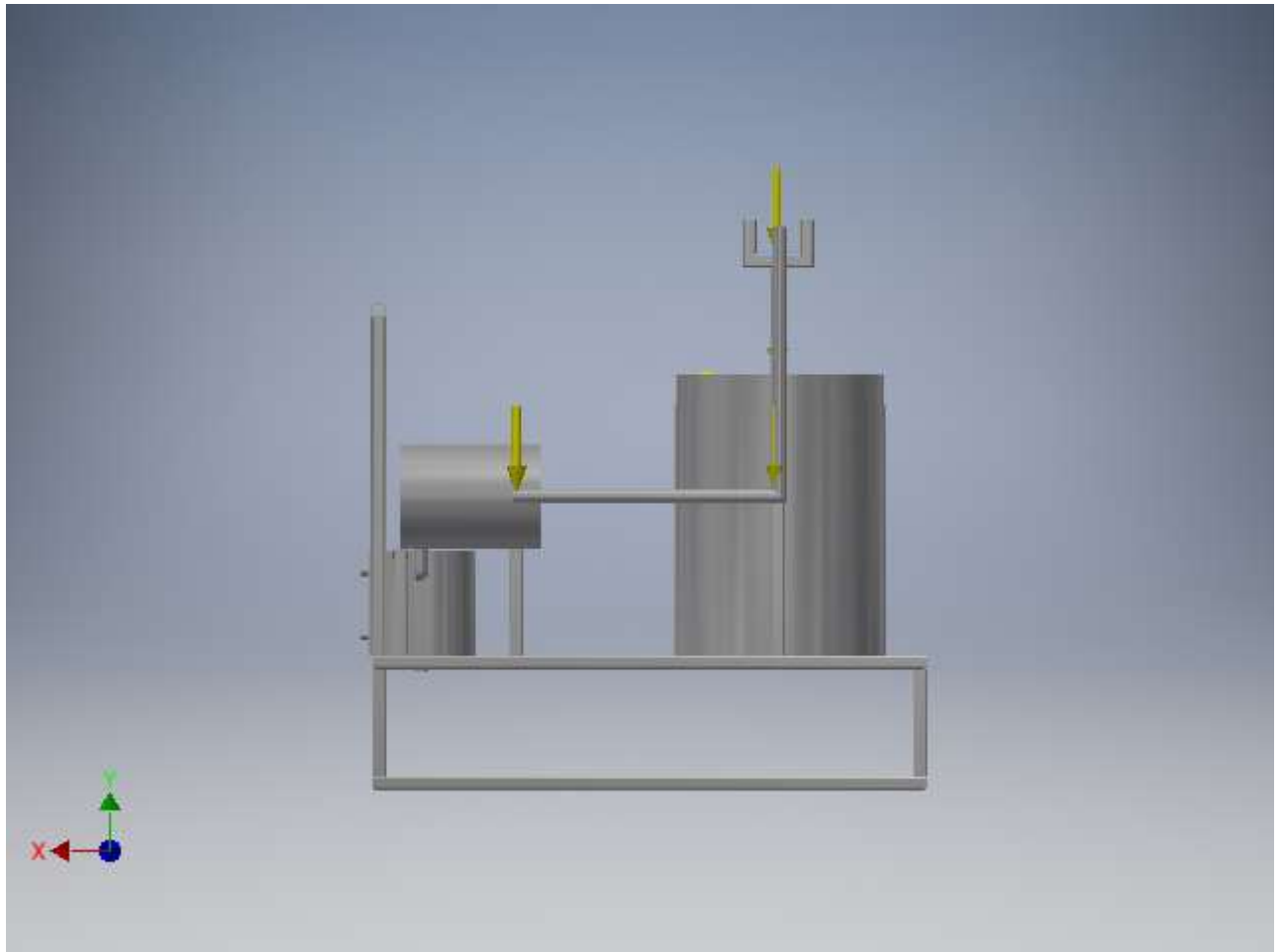

Remote Force:4

| Load Type | Remote Force |
|----------------|--------------|
| Magnitude | 25,000 N |
| Vector X | 0,000 N |
| Vector Y | -25,000 N |
| Vector Z | -0,000 N |
| Remote Point X | -185,000 mm |
| Remote Point Y | 30,000 mm |
| Remote Point Z | -260,000 mm |

Selected Face(s)

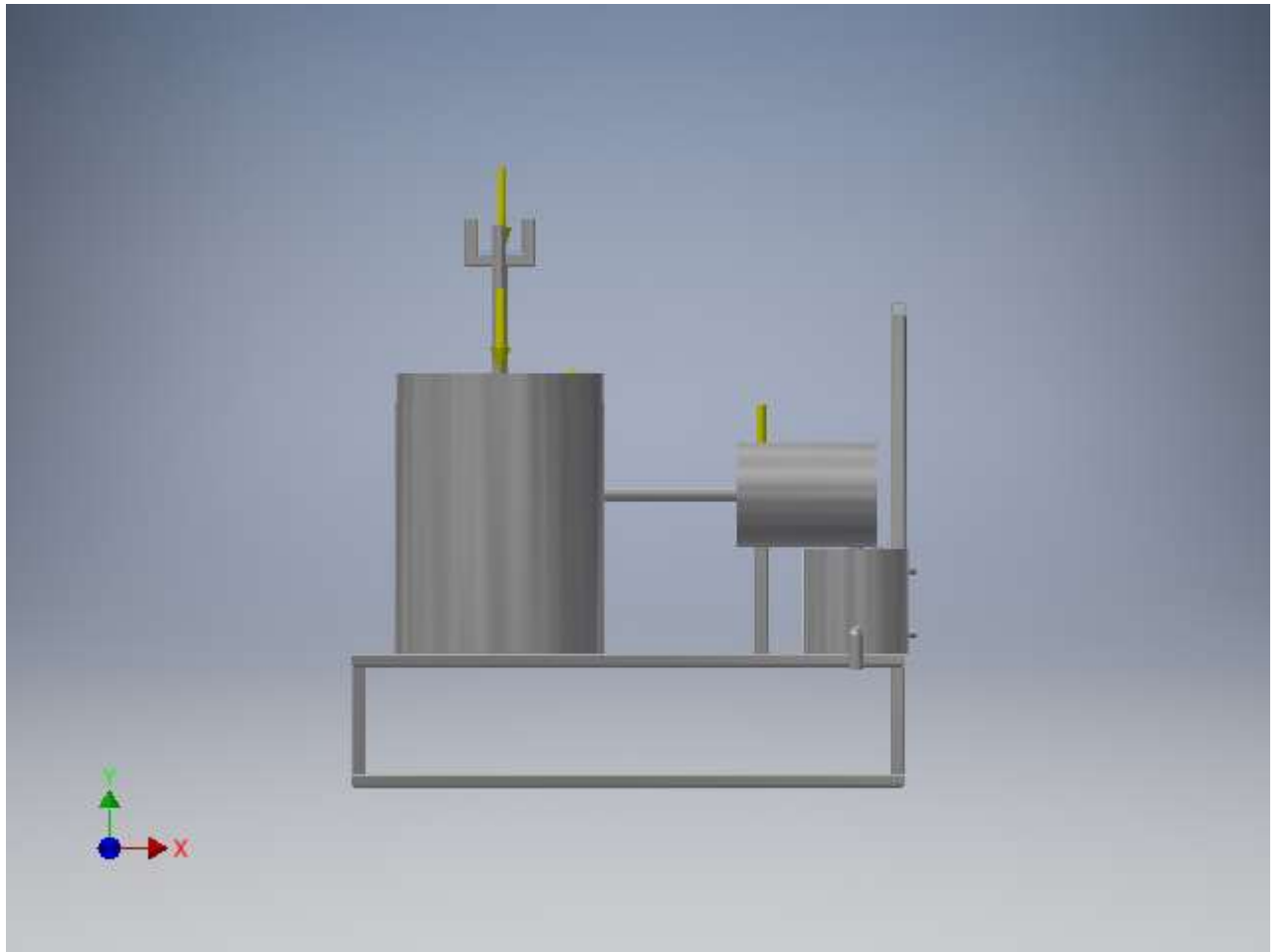

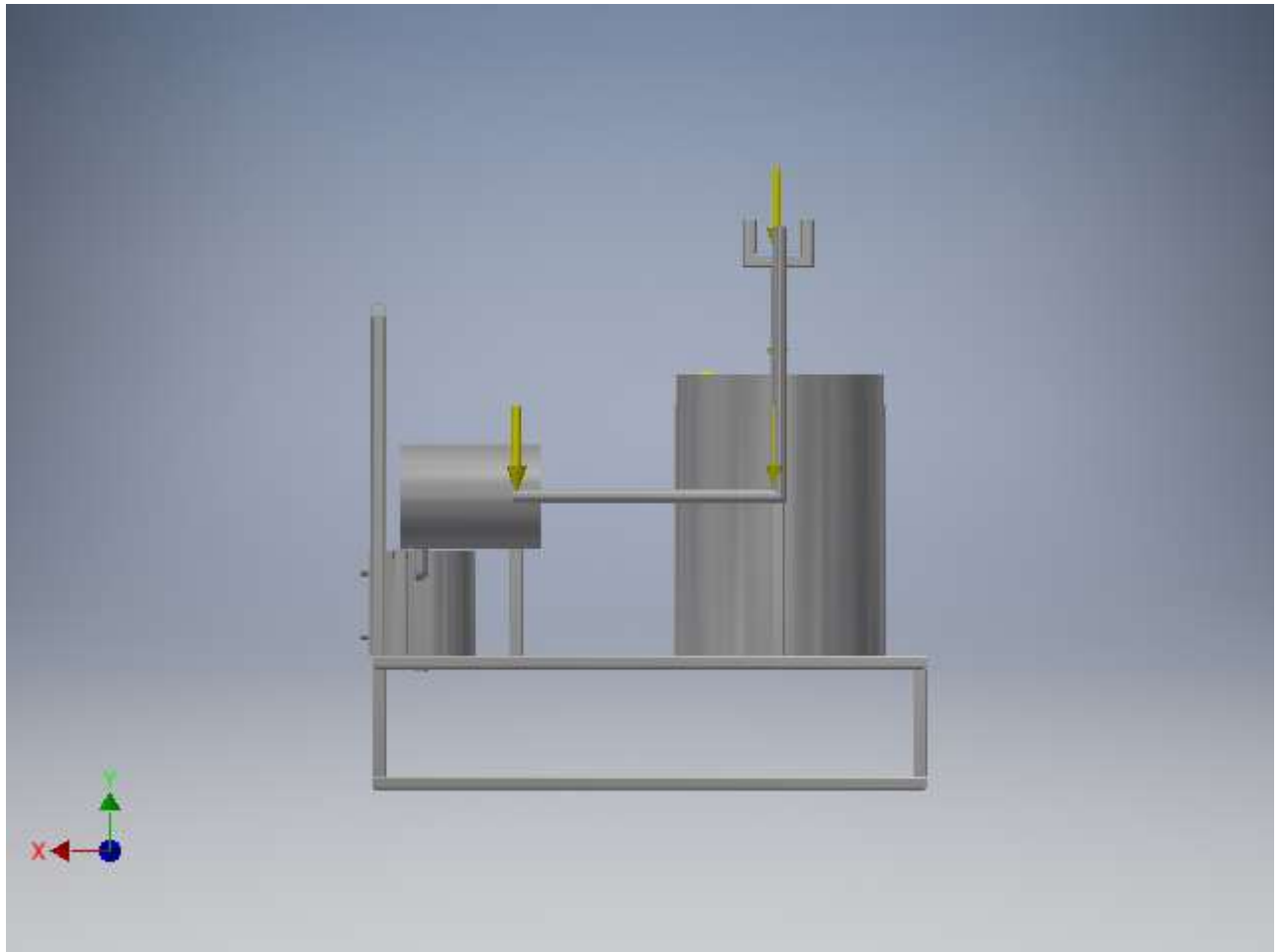

Remote Force:5

| Load Type | Remote Force |
|----------------|--------------|
| Magnitude | 25,000 N |
| Vector X | 0,000 N |
| Vector Y | -25,000 N |
| Vector Z | 0,000 N |
| Remote Point X | 180,000 mm |
| Remote Point Y | 30,000 mm |
| Remote Point Z | -260,000 mm |

Selected Face(s)

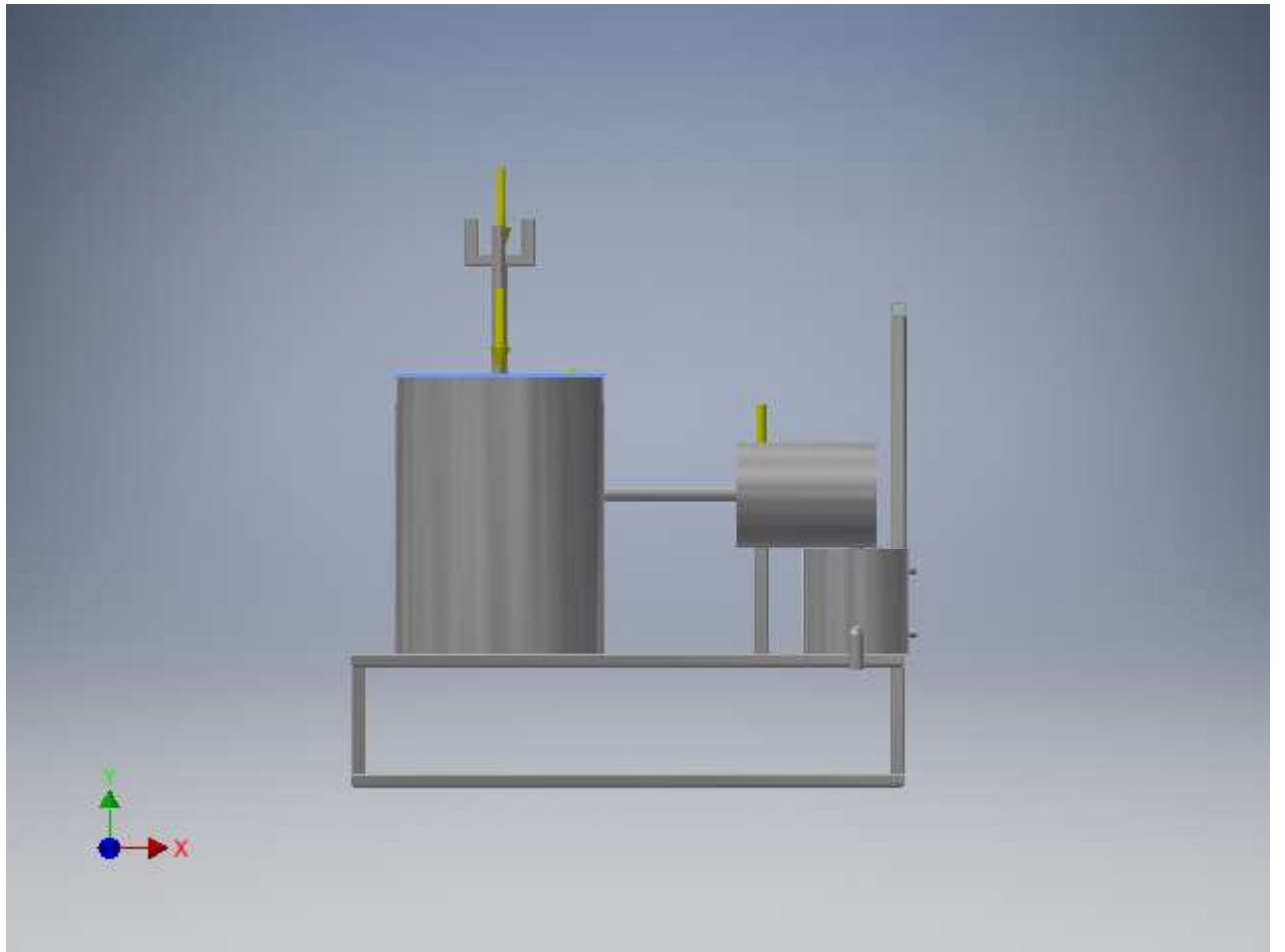

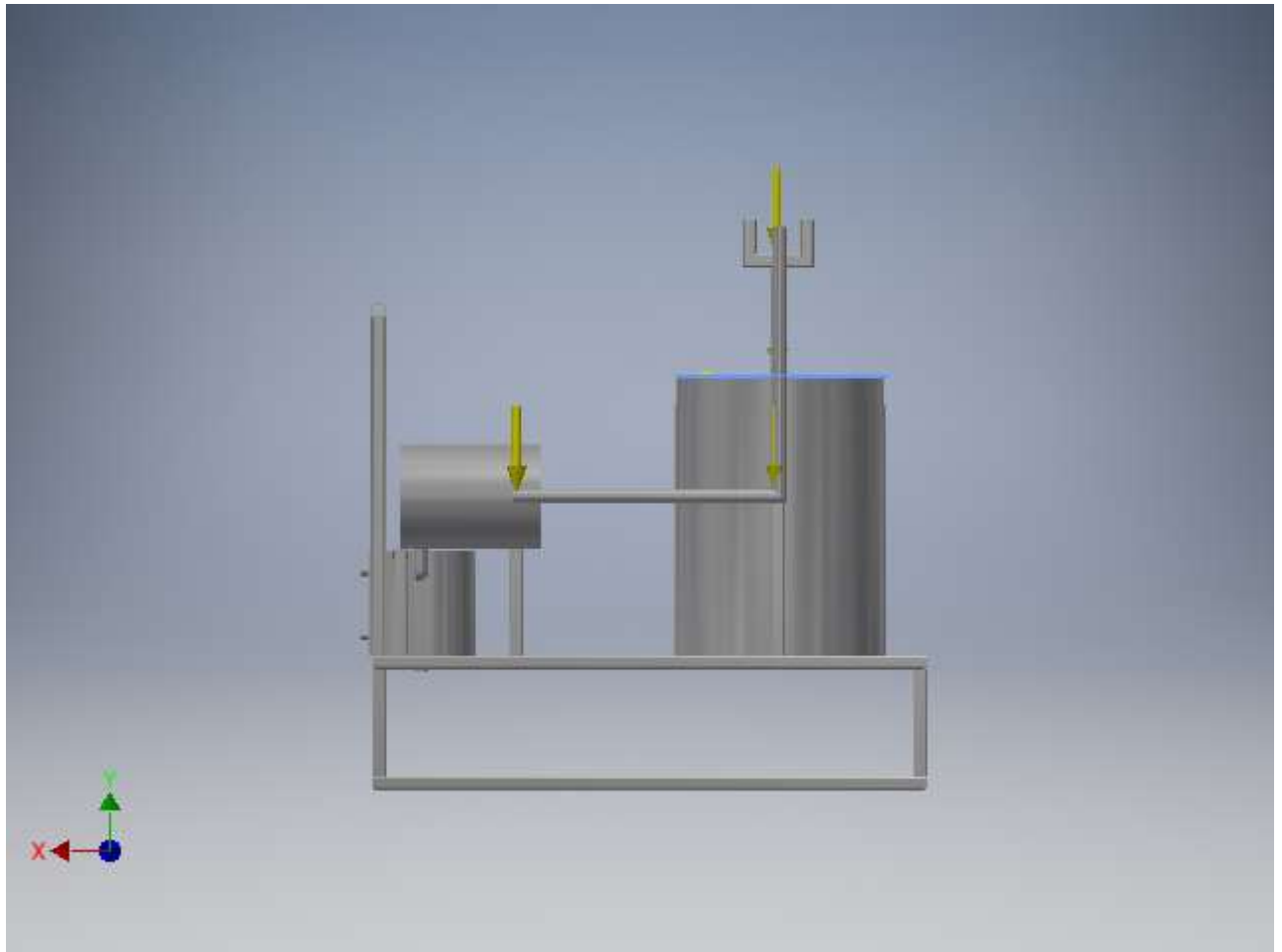

Remote Force:6

| Load Type | Remote Force |
|----------------|--------------|
| Magnitude | 40,000 N |
| Vector X | 0,000 N |
| Vector Y | -40,000 N |
| Vector Z | 0,000 N |
| Remote Point X | 310,000 mm |
| Remote Point Y | -195,000 mm |
| Remote Point Z | 130,000 mm |

Selected Face(s)

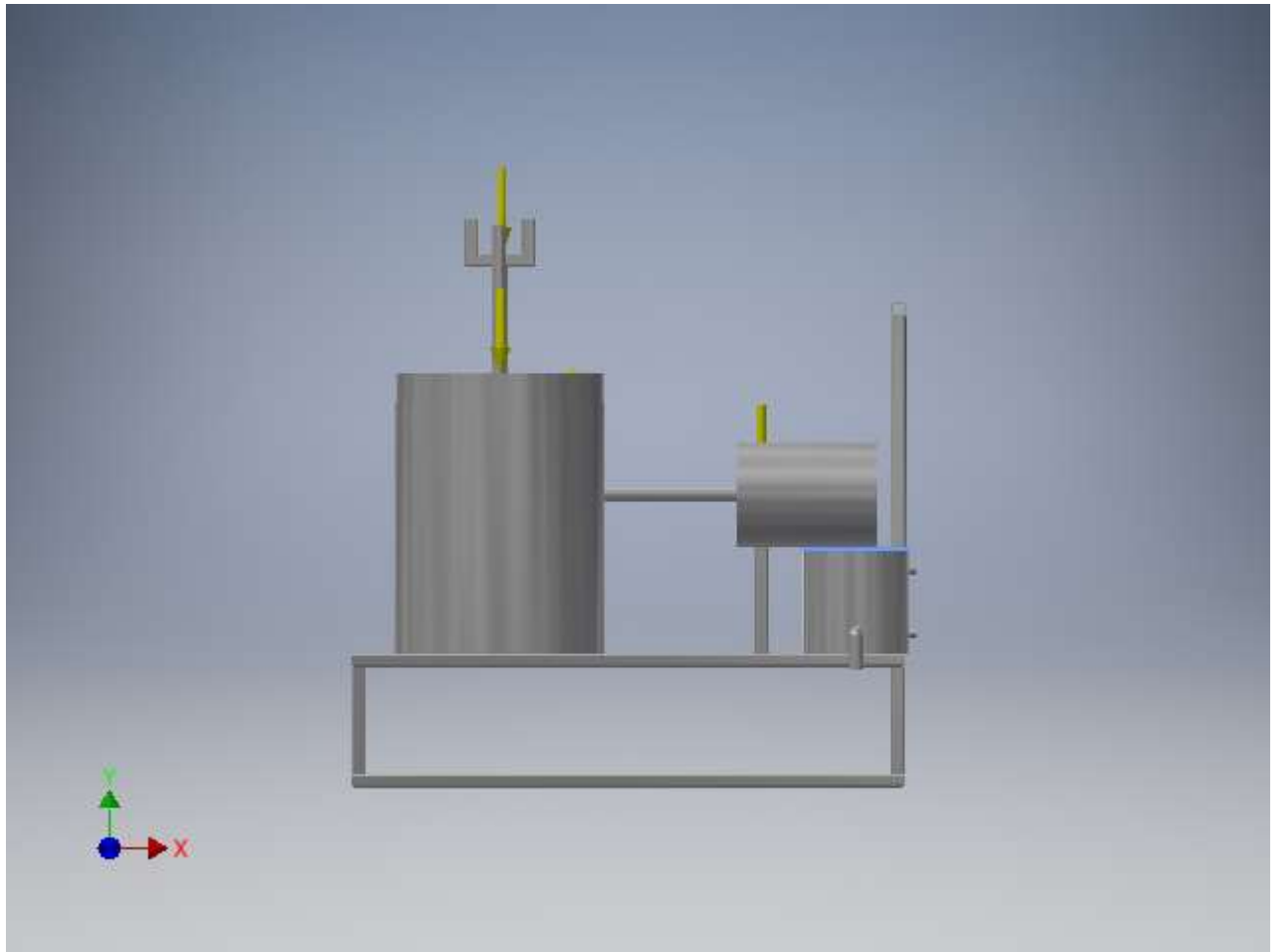

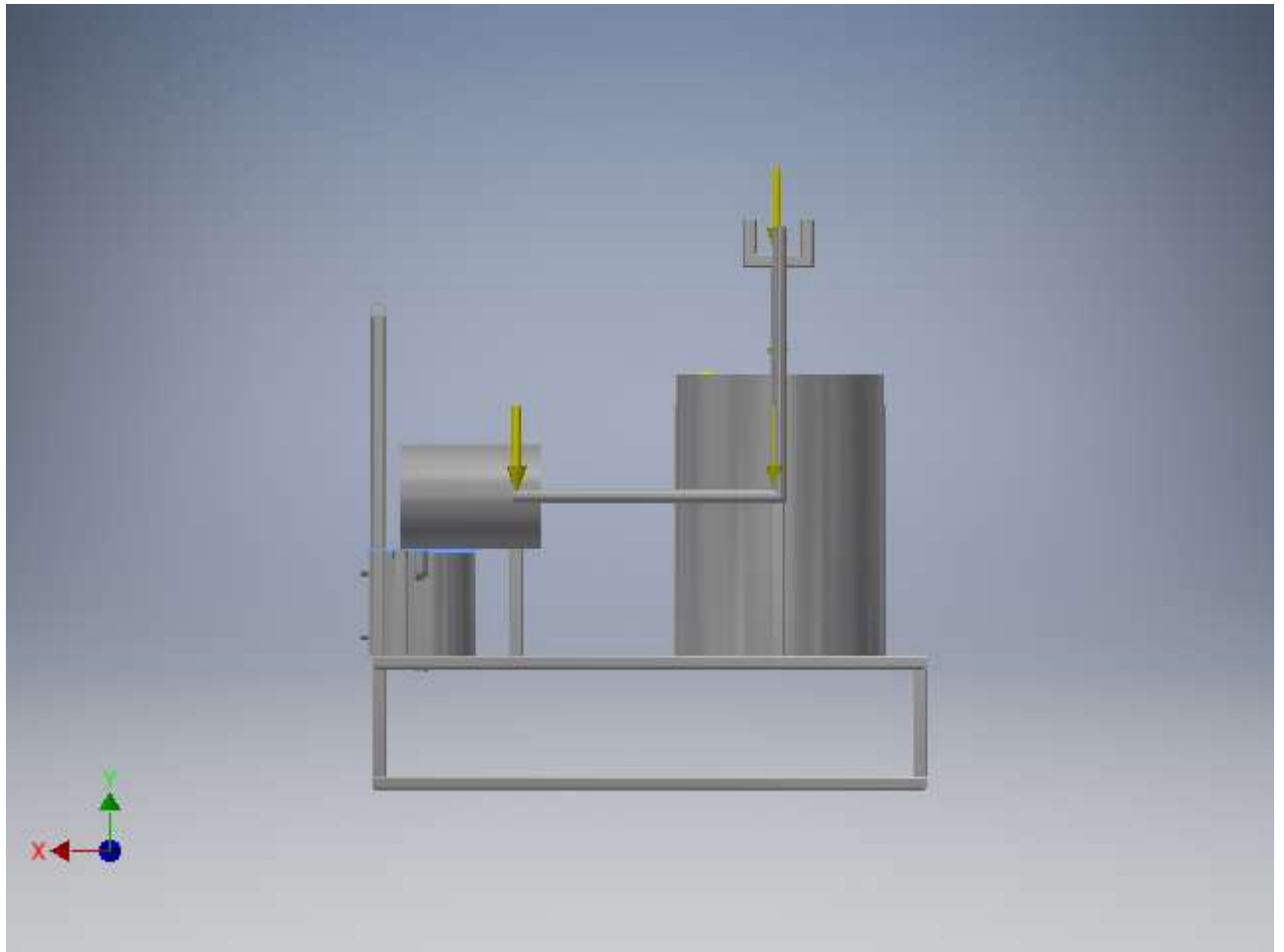

Remote Force:7

| Load Type | Remote Force |
|----------------|--------------|
| Magnitude | 25,000 N |
| Vector X | 0,000 N |
| Vector Y | -25,000 N |
| Vector Z | 0,000 N |
| Remote Point X | 310,000 mm |
| Remote Point Y | -50,000 mm |
| Remote Point Z | -50,000 mm |

Selected Face(s)

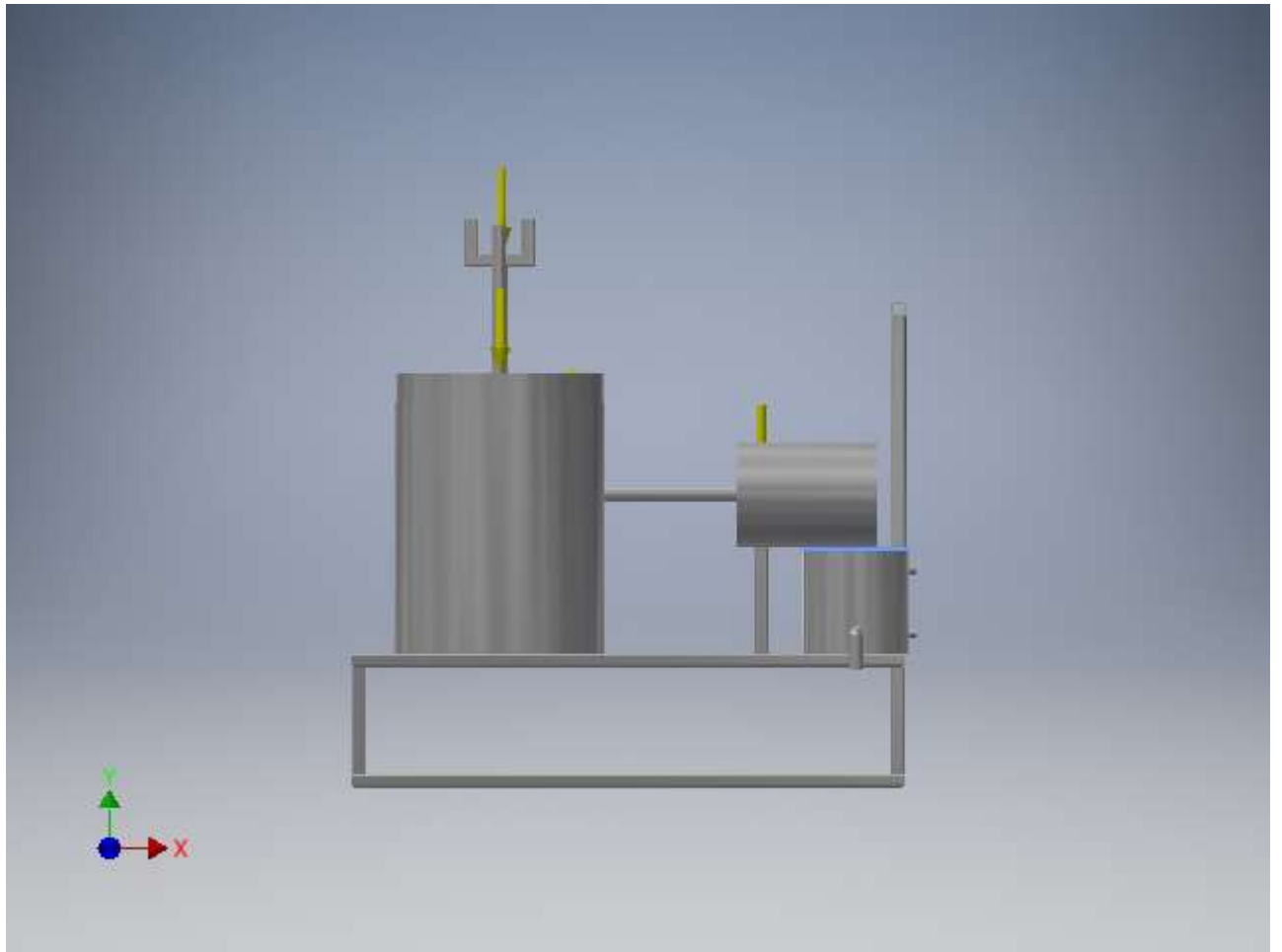

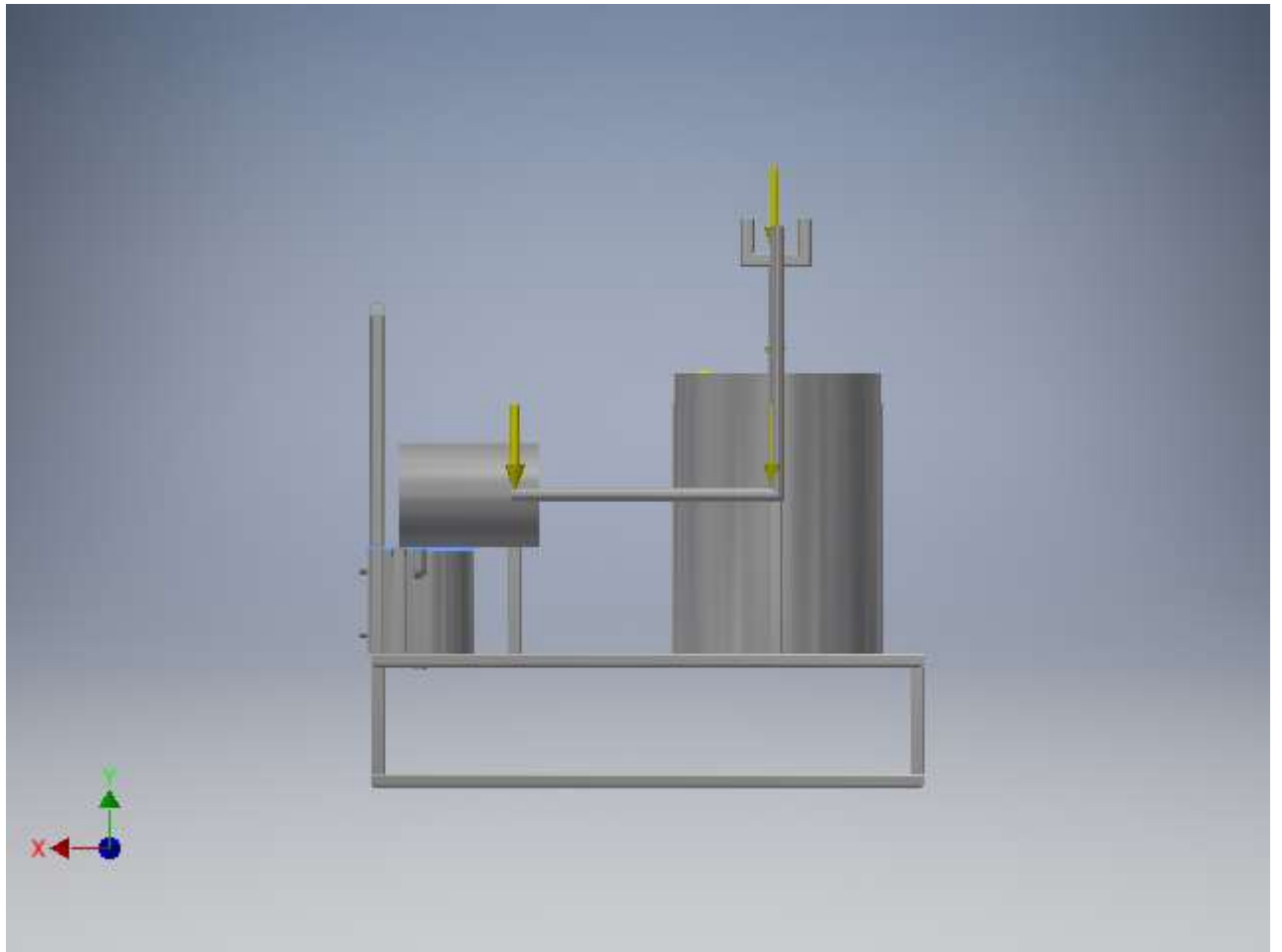

Pressure:1

| | |
|-----------|-----------|
| Load Type | Pressure |
| Magnitude | 0,500 MPa |

Selected Face(s)

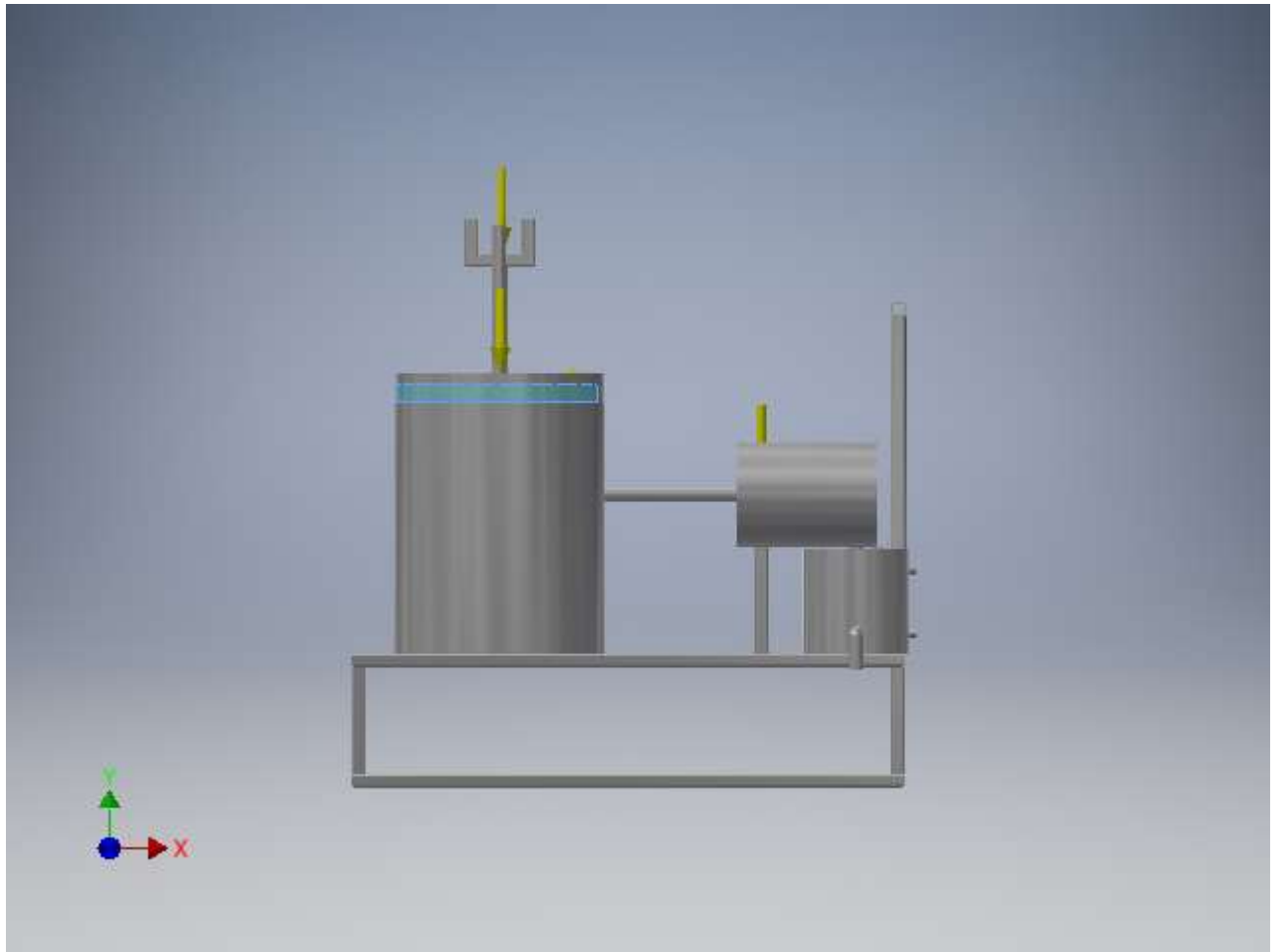

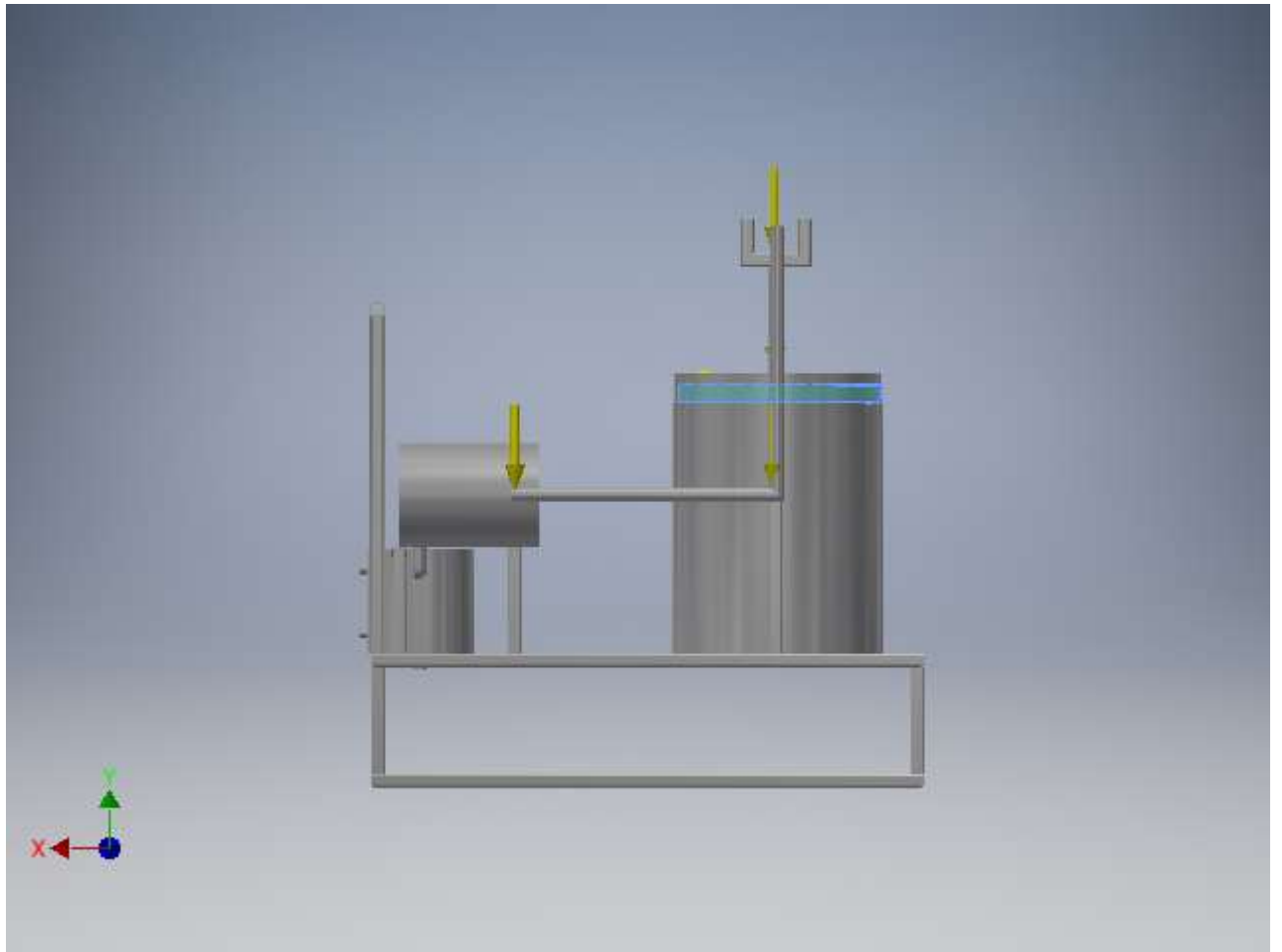

Pressure:2

| | |
|-----------|-----------|
| Load Type | Pressure |
| Magnitude | 0,500 MPa |

Selected Face(s)

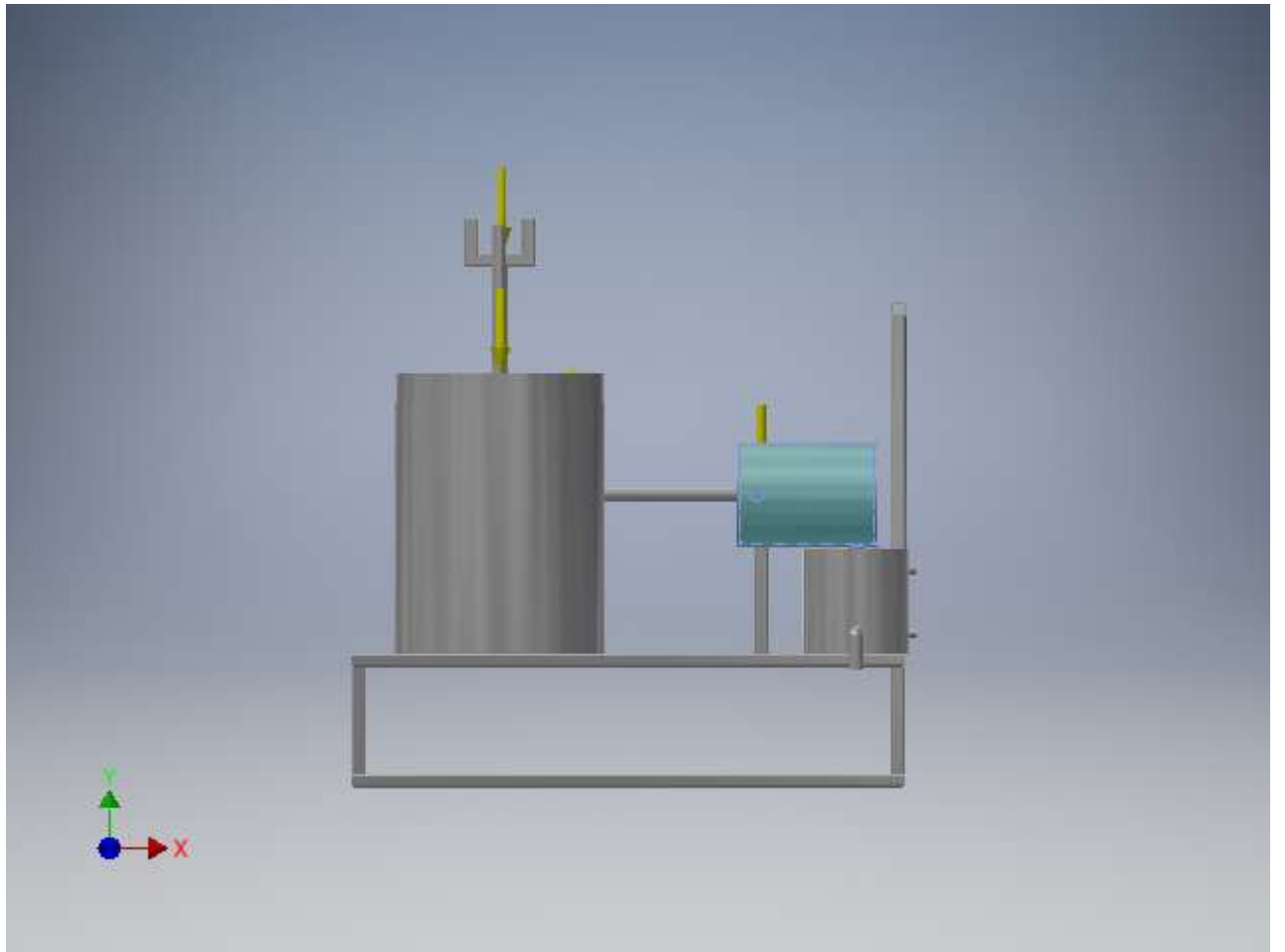

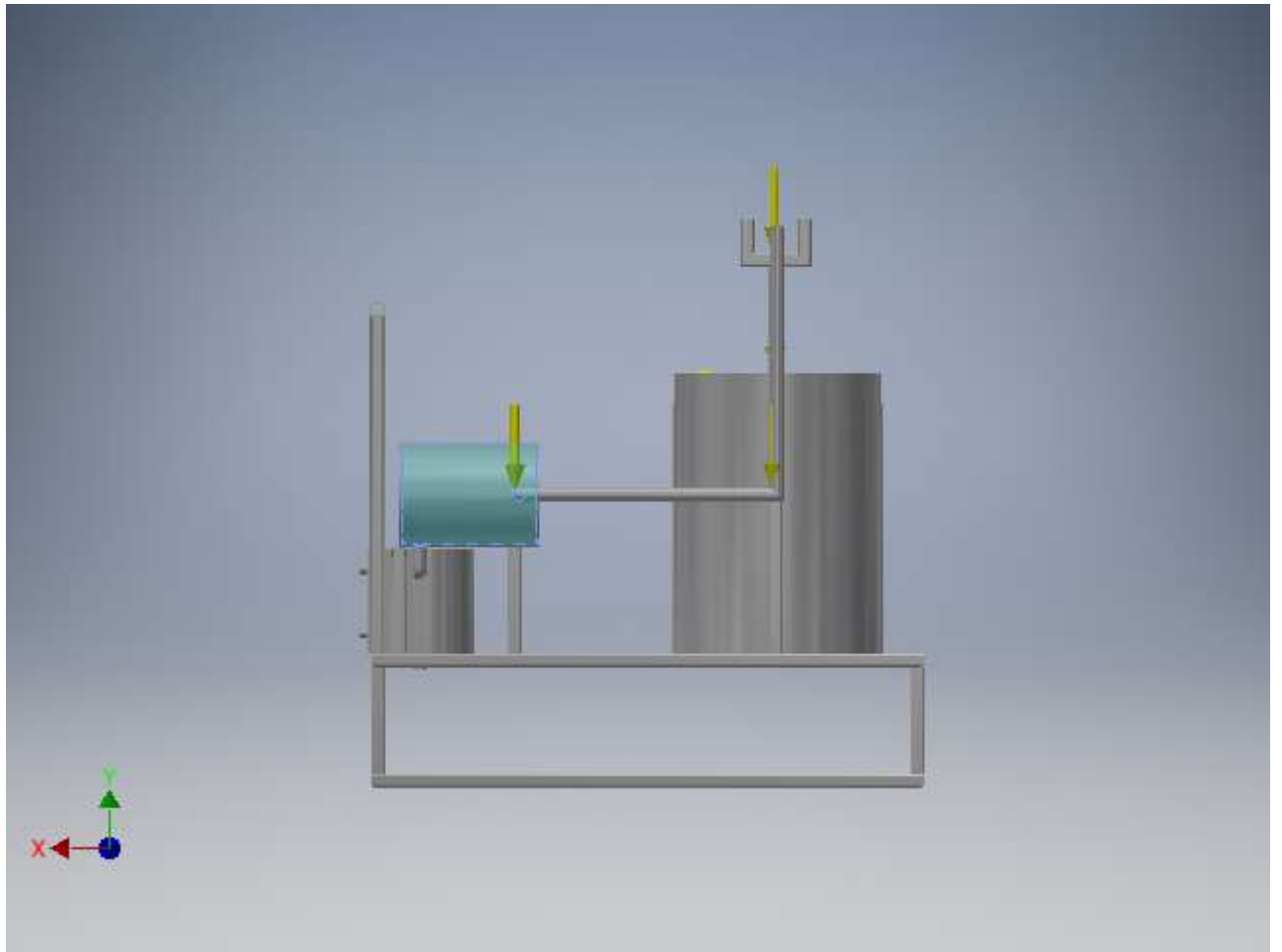

Pressure:3

| | |
|-----------|-----------|
| Load Type | Pressure |
| Magnitude | 0,500 MPa |

Selected Face(s)

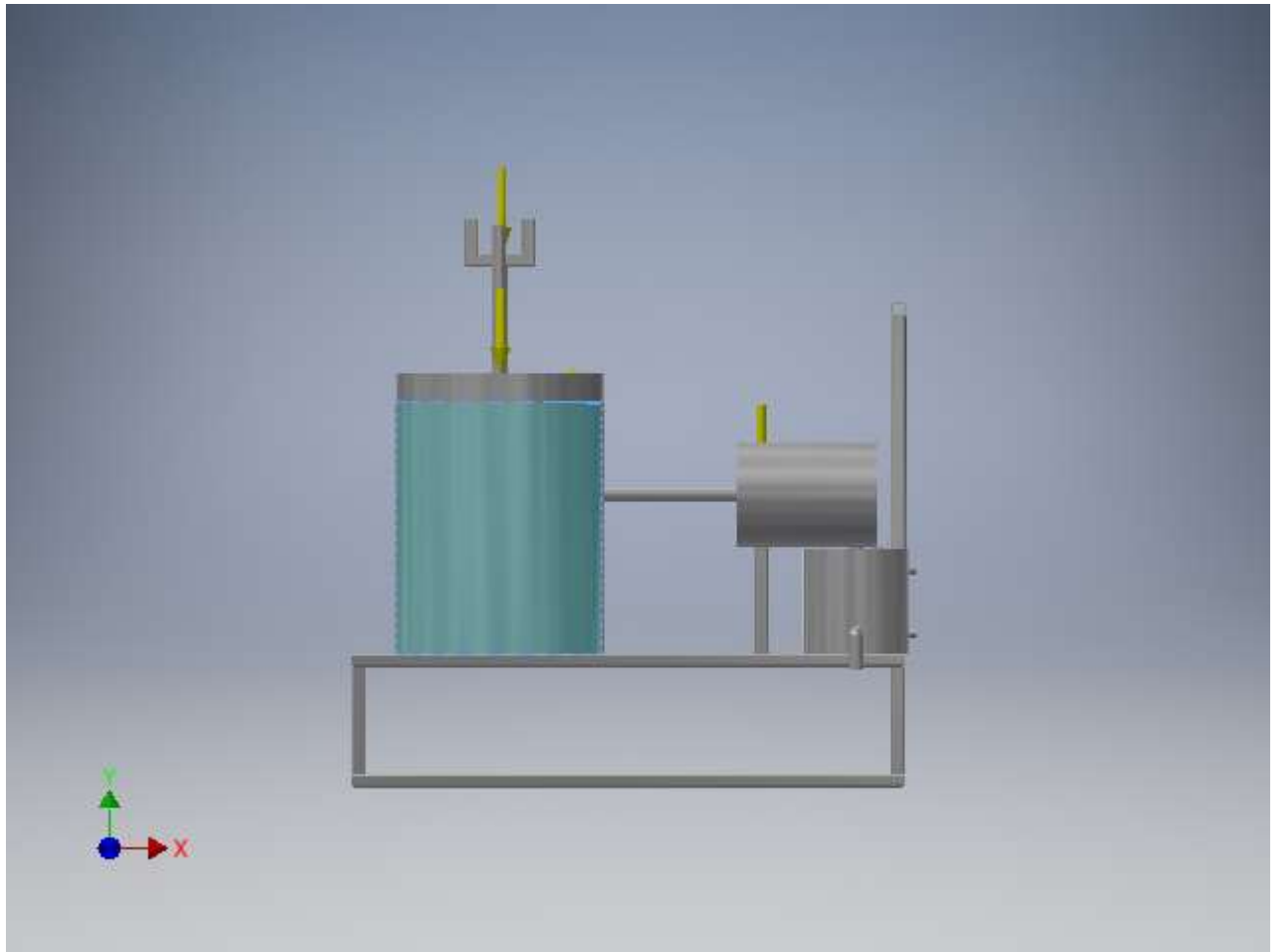

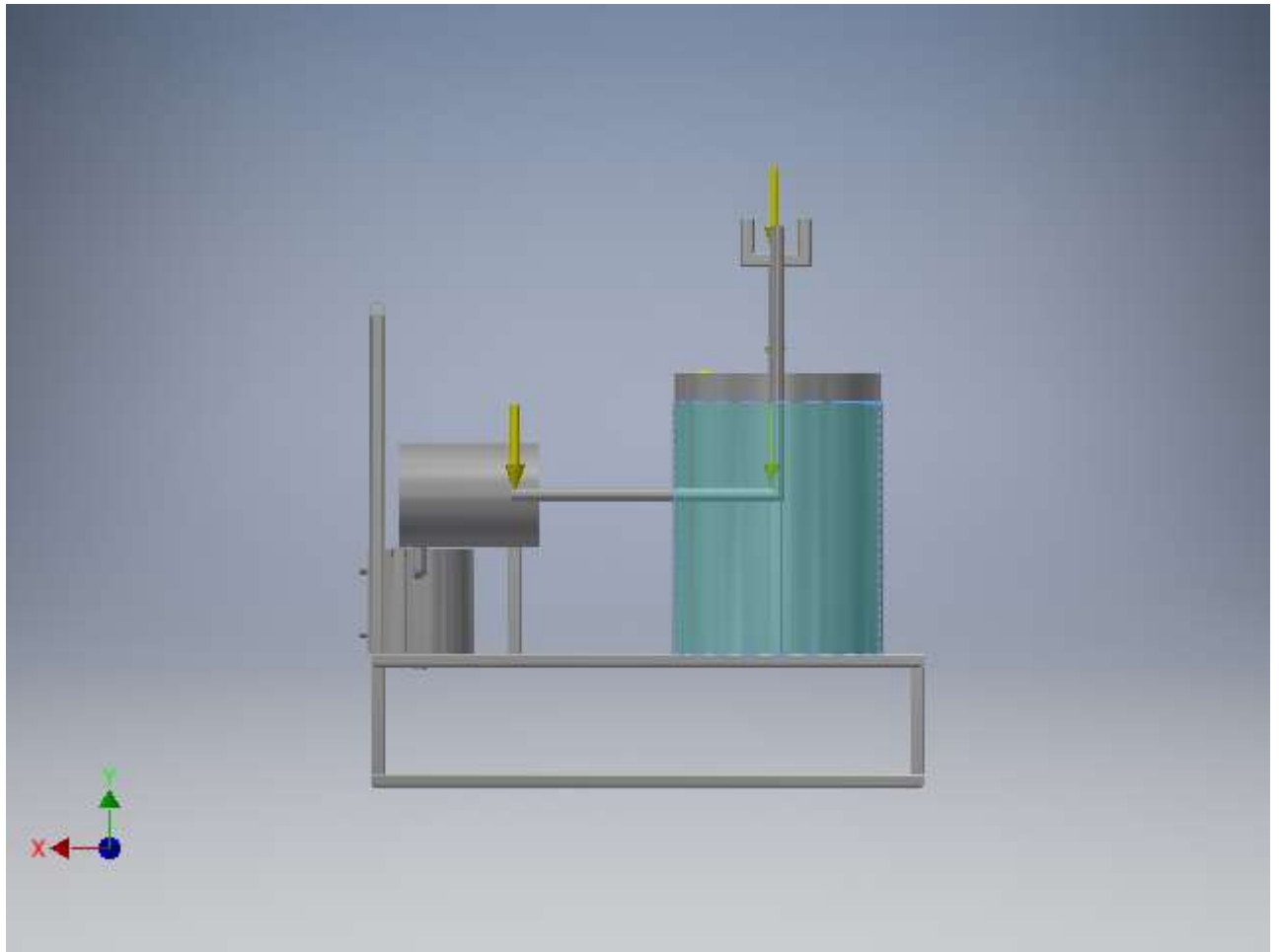

Pressure:4

| | |
|-----------|-----------|
| Load Type | Pressure |
| Magnitude | 0,500 MPa |

Selected Face(s)

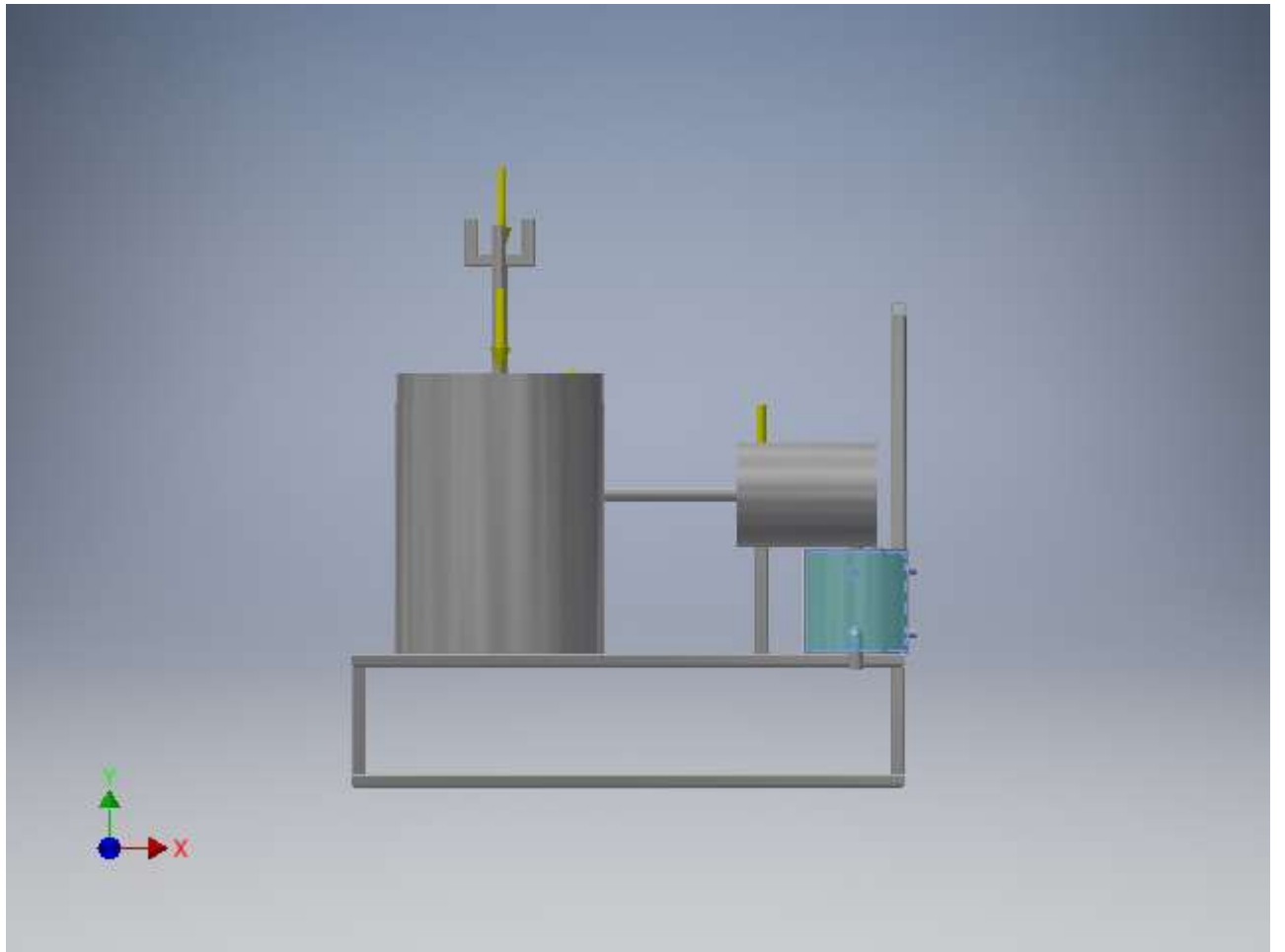

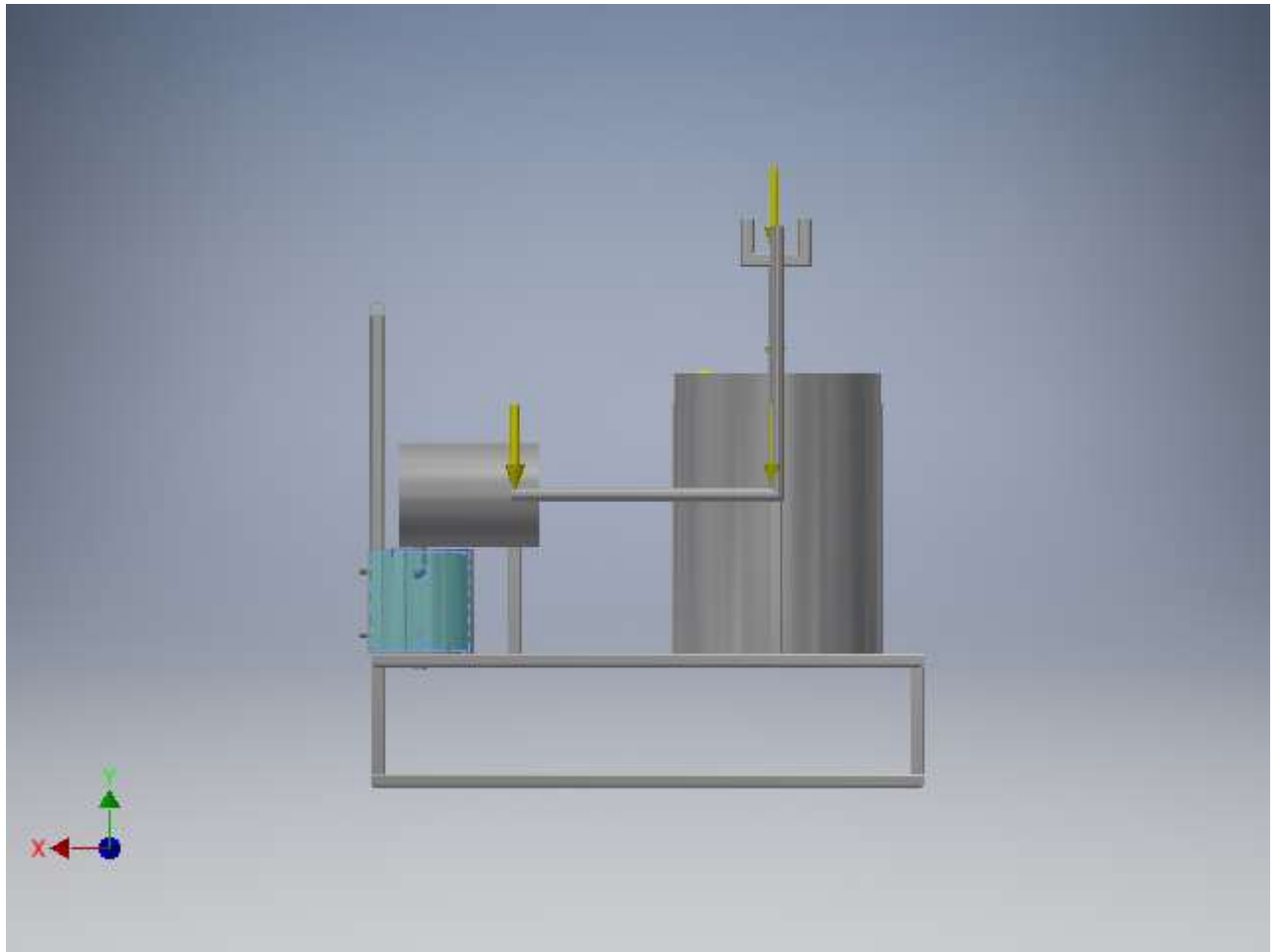

Fixed Constraint:1

Constraint Type Fixed Constraint

Selected Face(s)

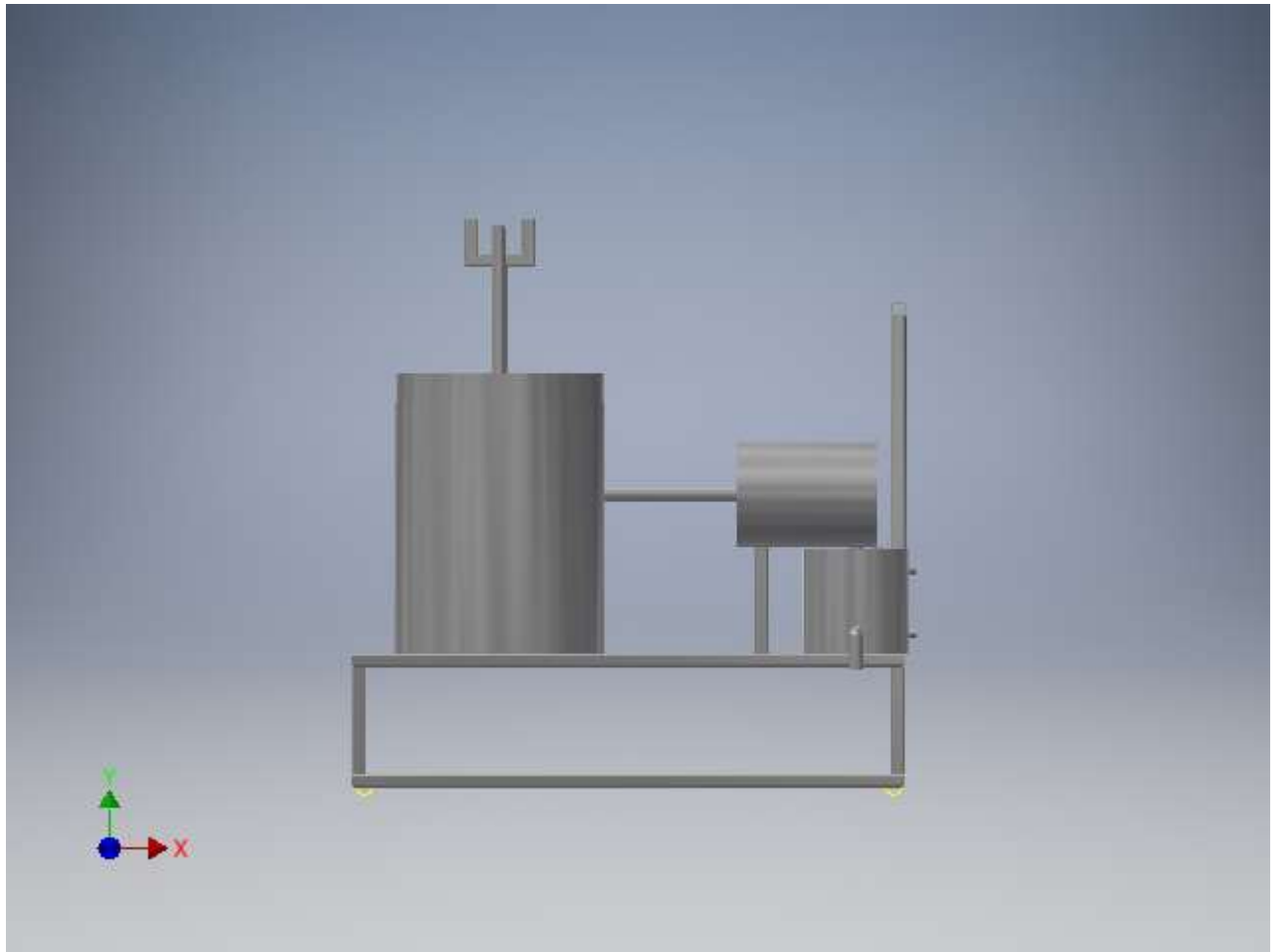

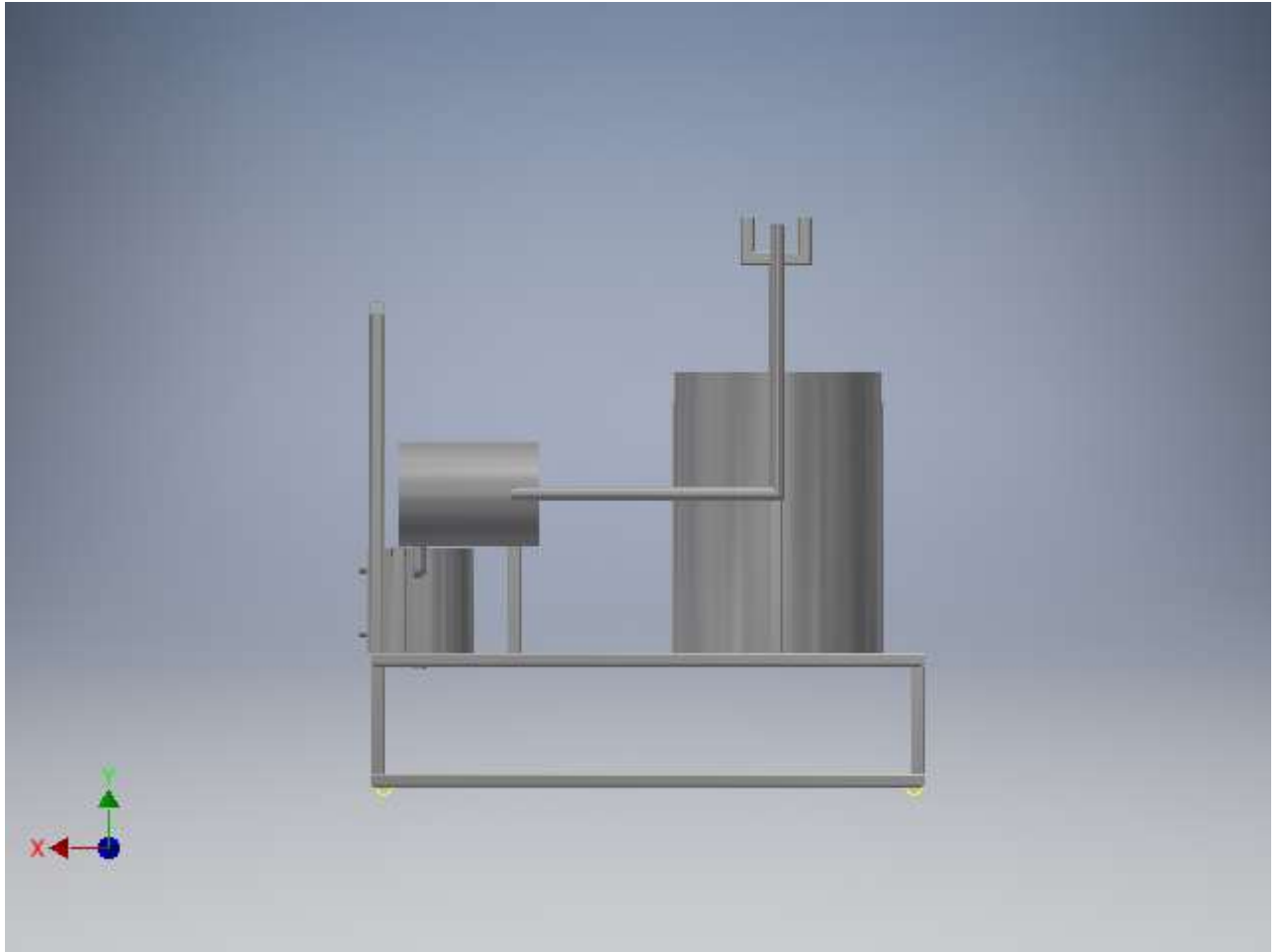

Fixed Constraint:2

| | |
|-----------------|------------------|
| Constraint Type | Fixed Constraint |
|-----------------|------------------|

Selected Face(s)

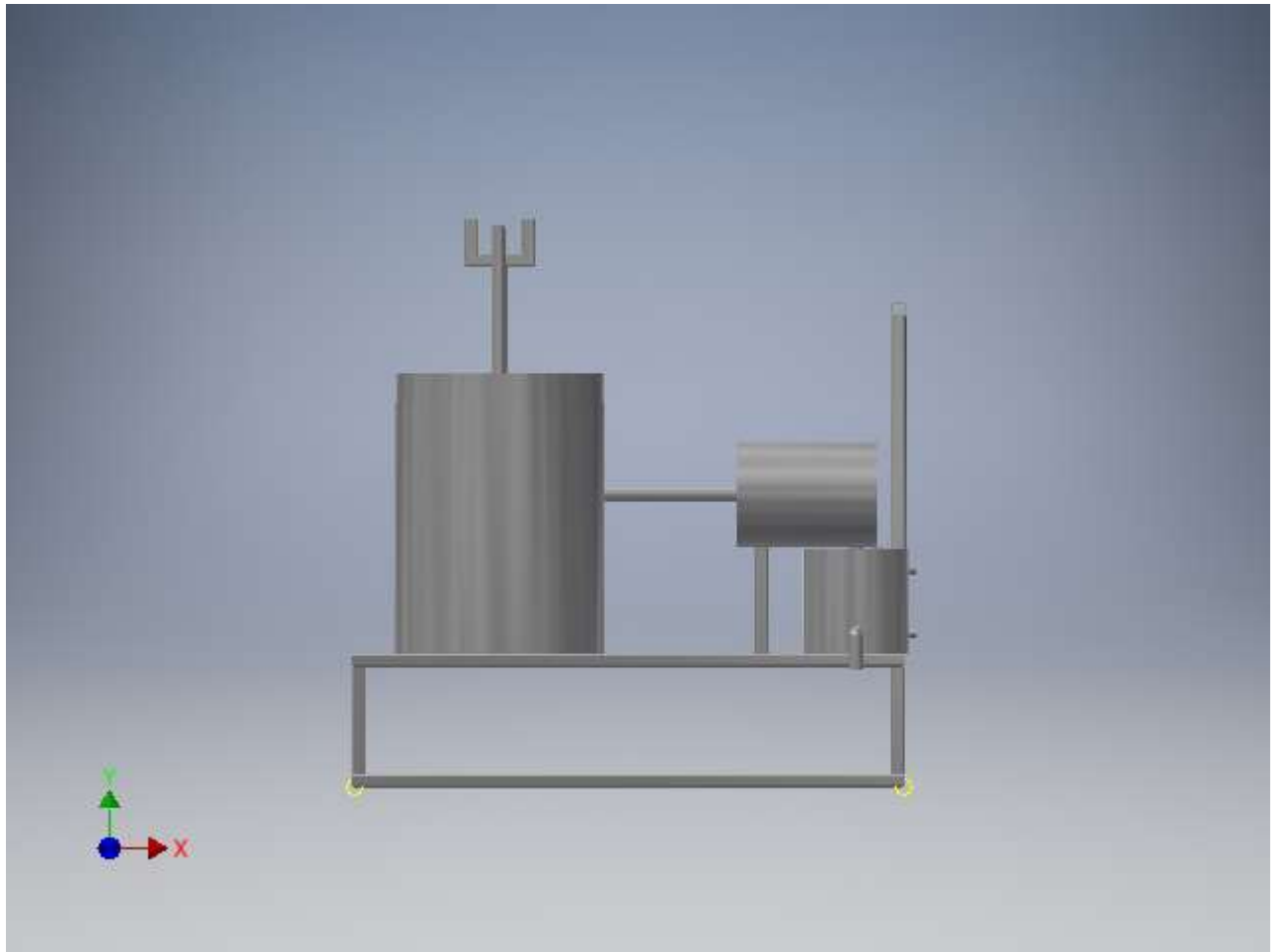

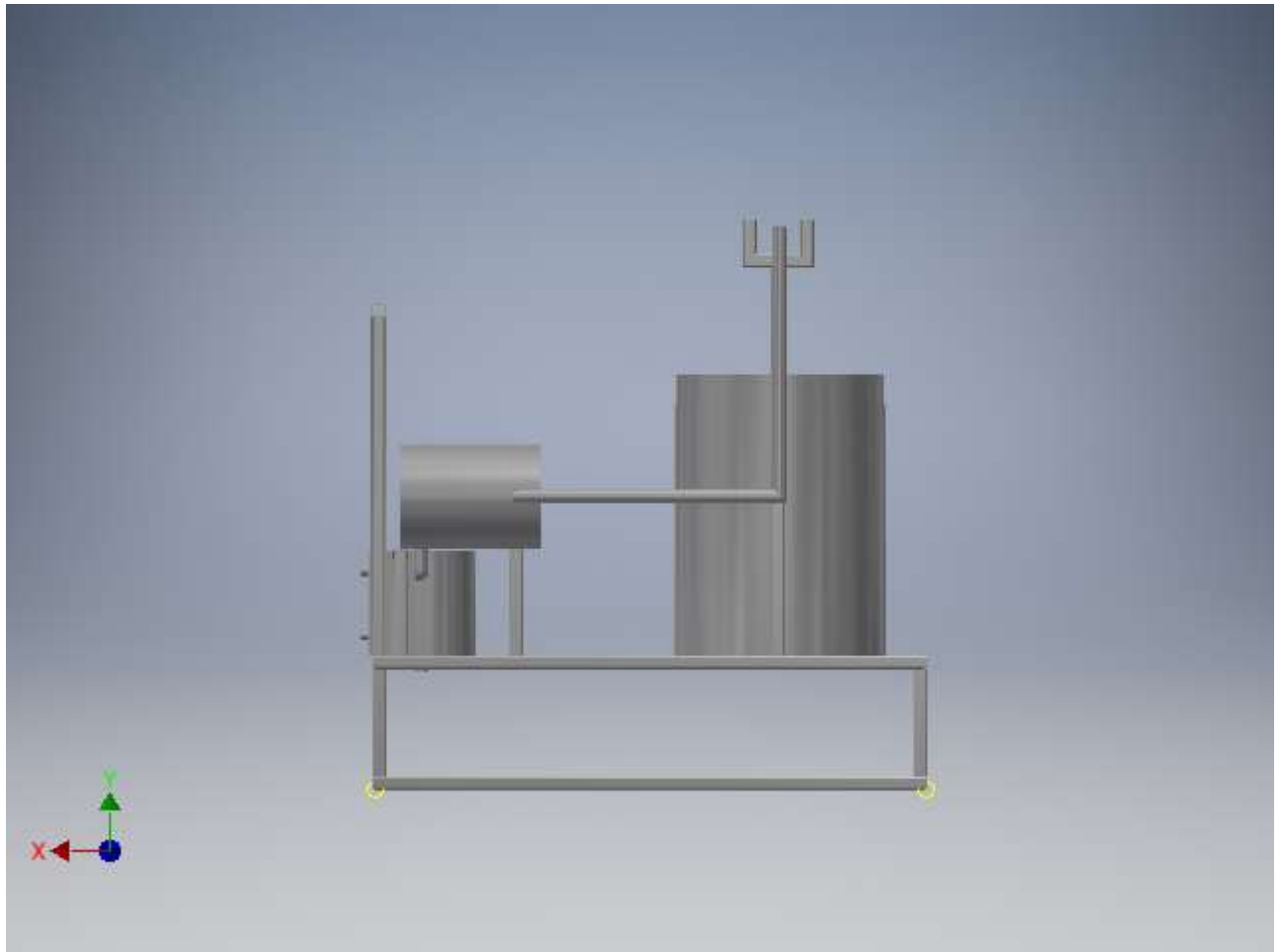

Contacts (Bonded)

| Name | Part Name(s) |
|-----------|--|
| Bonded:1 | uji rangka:1/Frame0001:1/ISO 20x20x2 00000014:1 reaktor uji:1/reaktor:1 |
| Bonded:2 | uji rangka:1/Frame0001:1/ISO 20x20x2 00000003:1 uji rangka:1/Frame0001:1/ISO 20x20x2 00000011:1 |
| Bonded:3 | uji rangka:1/Frame0001:1/ISO 20x20x2 00000003:1 uji rangka:1/Frame0001:1/ISO 20x20x2 00000010:1 |
| Bonded:4 | uji rangka:1/Frame0001:1/ISO 20x20x2 00000003:1 uji rangka:1/Frame0001:1/ISO 20x20x2 00000014:1 |
| Bonded:5 | uji rangka:1/Frame0001:1/ISO 20x20x2 00000003:1 uji rangka:1/Frame0001:1/ISO 20x20x2 00000015:1 |
| Bonded:6 | uji rangka:1/Frame0001:1/ISO 20x20x2 00000003:1 uji rangka:1/Frame0001:1/ISO 20x20x2 00000016:1 |
| Bonded:7 | uji rangka:1/Frame0001:1/ISO 20x20x2 00000003:1 uji rangka:1/Frame0001:1/ISO 20x20x2 00000013:1 |
| Bonded:8 | uji rangka:1/Frame0001:1/ISO 20x20x2 00000007:1 uji rangka:1/Frame0001:1/ISO 20x20x2 00000018:1 |
| Bonded:9 | uji rangka:1/Frame0001:1/ISO 20x20x2 00000007:1 uji rangka:1/Frame0001:1/ISO 20x20x2 00000019:1 |
| Bonded:10 | uji rangka:1/Frame0001:1/ISO 20x20x2 00000007:1 |

| | |
|-----------|--|
| | uji rangka:1/Frame0001:1/ISO 20x20x2 00000017:1 |
| Bonded:11 | uji rangka:1/Frame0001:1/ISO 20x20x2 00000005:1 uji rangka:1/Frame0001:1/ISO 20x20x2 00000011:1 |
| Bonded:12 | uji rangka:1/Frame0001:1/ISO 20x20x2 00000005:1 uji rangka:1/Frame0001:1/ISO 20x20x2 00000010:1 |
| Bonded:13 | uji rangka:1/Frame0001:1/ISO 20x20x2 00000005:1 uji rangka:1/Frame0001:1/ISO 20x20x2 00000017:1 |
| Bonded:14 | uji rangka:1/Frame0001:1/ISO 20x20x2 00000005:1 uji rangka:1/Frame0001:1/ISO 20x20x2 00000018:1 |
| Bonded:15 | uji rangka:1/Frame0001:1/ISO 20x20x2 00000005:1 uji rangka:1/Frame0001:1/ISO 20x20x2 00000019:1 |
| Bonded:16 | uji rangka:1/Frame0001:1/ISO 20x20x2 00000007:1 uji rangka:1/Frame0001:1/ISO 20x20x2 00000008:1 |
| Bonded:17 | uji rangka:1/Frame0001:1/ISO 20x20x2 00000003:1 uji rangka:1/Frame0001:1/ISO 20x20x2 00000004:1 |
| Bonded:18 | uji rangka:1/Frame0001:1/ISO 20x20x2 00000005:1 uji rangka:1/Frame0001:1/ISO 20x20x2 00000008:1 |
| Bonded:19 | uji rangka:1/Frame0001:1/ISO 20x20x2 00000001:1 uji rangka:1/Frame0001:1/ISO 20x20x2 00000022:1 |
| Bonded:20 | uji rangka:1/Frame0001:1/ISO 20x20x2 00000001:1 uji rangka:1/Frame0001:1/ISO 20x20x2 00000014:1 |
| Bonded:21 | uji rangka:1/Frame0001:1/ISO 20x20x2 00000001:1 uji rangka:1/Frame0001:1/ISO 20x20x2 00000015:1 |
| Bonded:22 | uji rangka:1/Frame0001:1/ISO 20x20x2 00000001:1 uji rangka:1/Frame0001:1/ISO 20x20x2 00000016:1 |
| Bonded:23 | uji rangka:1/Frame0001:1/ISO 20x20x2 00000001:1 uji rangka:1/Frame0001:1/ISO 20x20x2 00000013:1 |
| Bonded:24 | uji rangka:1/Frame0001:1/ISO 20x20x2 00000001:1 uji rangka:1/Frame0001:1/ISO 20x20x2 00000004:1 |
| Bonded:25 | uji rangka:1/Frame0001:1/ISO 20x20x2 00000031:1 uji rangka:1/Frame0001:1/ISO 20x20x2 00000032:1 |
| Bonded:26 | uji rangka:1/Frame0001:1/ISO 20x20x2 00000026:1 uji rangka:1/Frame0001:1/ISO 20x20x2 00000027:1 |
| Bonded:27 | uji rangka:1/Frame0001:1/ISO 20x20x2 00000015:1 uji rangka:1/Frame0001:1/ISO 20x20x2 00000028:1 |
| Bonded:28 | uji rangka:1/Frame0001:1/ISO 20x20x2 00000015:1 uji rangka:1/Frame0001:1/ISO 20x20x2 00000026:1 |
| Bonded:29 | uji rangka:1/Frame0001:1/ISO 20x20x2 00000016:1 uji rangka:1/Frame0001:1/ISO 20x20x2 00000033:1 |
| Bonded:30 | uji rangka:1/Frame0001:1/ISO 20x20x2 00000016:1 uji rangka:1/Frame0001:1/ISO 20x20x2 00000031:1 |
| Bonded:31 | uji rangka:1/Frame0001:1/ISO 20x20x2 00000018:1 uji rangka:1/Frame0001:1/ISO 20x20x2 00000021:1 |
| Bonded:32 | uji rangka:1/Frame0001:1/ISO 20x20x2 00000018:1 uji rangka:1/Frame0001:1/ISO 20x20x2 00000020:1 |
| Bonded:33 | uji rangka:1/Frame0001:1/ISO 20x20x2 00000014:1 reaktor uji:1/reaktor:1 |

| | |
|-----------|--|
| Bonded:34 | uji rangka:1/Frame0001:1/ISO 20x20x2 00000019:1 uji rangka:1/Frame0001:1/ISO 20x20x2 00000020:1 |
| Bonded:35 | uji rangka:1/Frame0001:1/ISO 20x20x2 00000019:1 uji rangka:1/Frame0001:1/ISO 20x20x2 00000021:1 |
| Bonded:36 | uji rangka:1/Frame0001:1/ISO 20x20x2 00000007:1 uji rangka:1/Frame0001:1/ISO 20x20x2 00000012:1 |
| Bonded:37 | uji rangka:1/Frame0001:1/ISO 20x20x2 00000007:1 uji rangka:1/Frame0001:1/ISO 20x20x2 00000009:1 |
| Bonded:38 | uji rangka:1/Frame0001:1/ISO 20x20x2 00000005:1 uji rangka:1/Frame0001:1/ISO 20x20x2 00000006:1 |
| Bonded:39 | uji rangka:1/Frame0001:1/ISO 20x20x2 00000008:1 uji rangka:1/Frame0001:1/ISO 20x20x2 00000009:1 |
| Bonded:40 | uji rangka:1/Frame0001:1/ISO 20x20x2 00000008:1 uji rangka:1/Frame0001:1/ISO 20x20x2 00000010:1 |
| Bonded:41 | uji rangka:1/Frame0001:1/ISO 20x20x2 00000029:1 uji rangka:1/Frame0001:1/ISO 20x20x2 00000030:1 |
| Bonded:42 | uji rangka:1/Frame0001:1/ISO 20x20x2 00000029:1 uji rangka:1/Frame0001:1/ISO 20x20x2 00000030:1 |
| Bonded:43 | uji rangka:1/Frame0001:1/ISO 20x20x2 00000029:1 uji rangka:1/Frame0001:1/ISO 20x20x2 00000030:1 |
| Bonded:44 | uji rangka:1/Frame0001:1/ISO 20x20x2 00000027:1 reaktor udara:1 |
| Bonded:45 | uji rangka:1/Frame0001:1/ISO 20x20x2 00000032:1 reaktor udara:1 |
| Bonded:46 | uji rangka:1/Frame0001:1/ISO 20x20x2 00000022:1 uji rangka:1/Frame0001:1/ISO 20x20x2 00000023:1 |
| Bonded:47 | uji rangka:1/Frame0001:1/ISO 20x20x2 00000022:1 uji rangka:1/Frame0001:1/ISO 20x20x2 00000023:1 |
| Bonded:48 | uji rangka:1/Frame0001:1/ISO 20x20x2 00000022:1 uji rangka:1/Frame0001:1/ISO 20x20x2 00000023:1 |
| Bonded:49 | uji rangka:1/Frame0001:1/ISO 20x20x2 00000013:1 reaktor uji:1/reaktor:1 |
| Bonded:50 | uji rangka:1/Frame0001:1/ISO 20x20x2 00000004:1 uji rangka:1/Frame0001:1/ISO 20x20x2 00000011:1 |
| Bonded:51 | uji rangka:1/Frame0001:1/ISO 20x20x2 00000004:1 uji rangka:1/Frame0001:1/ISO 20x20x2 00000012:1 |
| Bonded:52 | uji rangka:1/Frame0001:1/ISO 20x20x2 00000001:1 uji rangka:1/Frame0001:1/ISO 20x20x2 00000009:1 |
| Bonded:53 | uji rangka:1/Frame0001:1/ISO 20x20x2 00000001:1 uji rangka:1/Frame0001:1/ISO 20x20x2 00000012:1 |
| Bonded:54 | uji rangka:1/Frame0001:1/ISO 20x20x2 00000032:1 reaktor udara:1 |
| Bonded:55 | uji rangka:1/Frame0001:1/ISO 20x20x2 00000027:1 reaktor udara:1 |
| Bonded:56 | uji rangka:1/Frame0001:1/ISO 20x20x2 00000027:1 reaktor udara:1 |
| Bonded:57 | uji rangka:1/Frame0001:1/ISO 20x20x2 00000013:1 reaktor uji:1/reaktor:1 |

| | |
|-----------|--|
| Bonded:58 | uji rangka:1/Frame0001:1/ISO 20x20x2 00000032:1 uji rangka:1/Frame0001:1/ISO 20x20x2 00000033:1 |
| Bonded:59 | uji rangka:1/Frame0001:1/ISO 20x20x2 00000027:1 uji rangka:1/Frame0001:1/ISO 20x20x2 00000028:1 |
| Bonded:60 | uji rangka:1/Frame0001:1/ISO 20x20x2 00000006:1 uji rangka:1/Frame0001:1/ISO 20x20x2 00000007:1 |
| Bonded:61 | uji rangka:1/Frame0001:1/ISO 20x20x2 00000023:1 uji rangka:1/Frame0001:1/ISO 20x20x2 00000025:1 |
| Bonded:62 | uji rangka:1/Frame0001:1/ISO 20x20x2 00000002:1 uji rangka:1/Frame0001:1/ISO 20x20x2 00000010:1 |
| Bonded:63 | uji rangka:1/Frame0001:1/ISO 20x20x2 00000006:1 uji rangka:1/Frame0001:1/ISO 20x20x2 00000012:1 |
| Bonded:64 | uji rangka:1/Frame0001:1/ISO 20x20x2 00000002:1 uji rangka:1/Frame0001:1/ISO 20x20x2 00000009:1 |
| Bonded:65 | uji rangka:1/Frame0001:1/ISO 20x20x2 00000006:1 uji rangka:1/Frame0001:1/ISO 20x20x2 00000011:1 |
| Bonded:66 | uji rangka:1/Frame0001:1/ISO 20x20x2 00000004:1 uji rangka:1/Frame0001:1/ISO 20x20x2 00000029:1 |
| Bonded:67 | uji rangka:1/Frame0001:1/ISO 20x20x2 00000002:1 uji rangka:1/Frame0001:1/ISO 20x20x2 00000003:1 |
| Bonded:68 | uji rangka:1/Frame0001:1/ISO 20x20x2 00000001:1 uji rangka:1/Frame0001:1/ISO 20x20x2 00000002:1 |
| Bonded:69 | uji rangka:1/Frame0001:1/ISO 20x20x2 00000023:1 uji rangka:1/Frame0001:1/ISO 20x20x2 00000024:1 |
| Bonded:70 | reaktor udara:1 Frame0007:1/ISO 21.3x2.0 00000032:1 |
| Bonded:71 | reaktor udara:1 kondensor air oke:1 |
| Bonded:72 | Frame0007:1/ISO 21.3x2.0 00000034:1 Frame0007:1/ISO 21.3x2.0 00000035:1 |
| Bonded:73 | Frame0007:1/ISO 21.3x2.0 00000031:1 Frame0007:1/ISO 21.3x2.0 00000033:1 |
| Bonded:74 | Frame0007:1/ISO 21.3x2.0 00000033:1 Frame0007:1/ISO 21.3x2.0 00000034:1 |
| Bonded:75 | Frame0007:1/ISO 21.3x2.0 00000031:1 Frame0007:1/ISO 21.3x2.0 00000032:1 |
| Bonded:76 | reaktor uji:1/tutup oke:1 Frame0007:1/ISO 21.3x2.0 00000035:1 |
| Bonded:77 | reaktor uji:1/reaktor:1 reaktor uji:1/tutup oke:1 |

Results

Reaction Force and Moment on Constraints

| Constraint Name | Reaction Force | | Reaction Moment | |
|--------------------|----------------|-------------------|-----------------|-------------------|
| | Magnitude | Component (X,Y,Z) | Magnitude | Component (X,Y,Z) |
| Fixed Constraint:1 | 155,598 N | 83,9151 N | 165,533 N m | 15,7119 N m |

| | | | | |
|--------------------|-----------|------------|------------|--------------|
| | | -97,8919 N | | 35,9317 N m |
| | | -87,0983 N | | 160,821 N m |
| Fixed Constraint:2 | 171,629 N | 55,086 N | 230,33 N m | -58,3343 N m |
| | | 160,768 N | | 1,03237 N m |
| | | -23,9951 N | | -222,819 N m |

Result Summary

| Name | Minimum | Maximum |
|----------------------|-------------------------|-----------------|
| Volume | 5785770 mm ³ | |
| Mass | 46,086 kg | |
| Von Mises Stress | 0,00208749 MPa | 444,947 MPa |
| 1st Principal Stress | -134,398 MPa | 467,274 MPa |
| 3rd Principal Stress | -486,719 MPa | 64,3589 MPa |
| Displacement | 0 mm | 5,4951 mm |
| Safety Factor | 0,561865 ul | 15 ul |
| Stress XX | -408,615 MPa | 149,908 MPa |
| Stress XY | -86,1412 MPa | 143,143 MPa |
| Stress XZ | -83,0316 MPa | 109,087 MPa |
| Stress YY | -346,012 MPa | 354,367 MPa |
| Stress YZ | -147,142 MPa | 210,833 MPa |
| Stress ZZ | -422,271 MPa | 307,7 MPa |
| X Displacement | -3,544 mm | 0,430928 mm |
| Y Displacement | -4,20378 mm | 0,0323299 mm |
| Z Displacement | -1,86724 mm | 1,48467 mm |
| Equivalent Strain | 0,00000000865507 ul | 0,00207466 ul |
| 1st Principal Strain | -0,000023523 ul | 0,00202247 ul |
| 3rd Principal Strain | -0,00238965 ul | 0,0000427608 ul |
| Strain XX | -0,00152467 ul | 0,000824087 ul |
| Strain XY | -0,000580225 ul | 0,000964174 ul |
| Strain XZ | -0,00055928 ul | 0,000734784 ul |
| Strain YY | -0,00150271 ul | 0,0013813 ul |
| Strain YZ | -0,00099111 ul | 0,00142012 ul |
| Strain ZZ | -0,00193727 ul | 0,00134662 ul |
| Contact Pressure | 0 MPa | 476,85 MPa |
| Contact Pressure X | -326,437 MPa | 314,278 MPa |
| Contact Pressure Y | -295,608 MPa | 359,327 MPa |
| Contact Pressure Z | -336,555 MPa | 273,513 MPa |

Figures

Von Mises Stress

Type: Von Mises Stress

Unit: MPa

23/07/2019, 4:36:25

444,9 Max

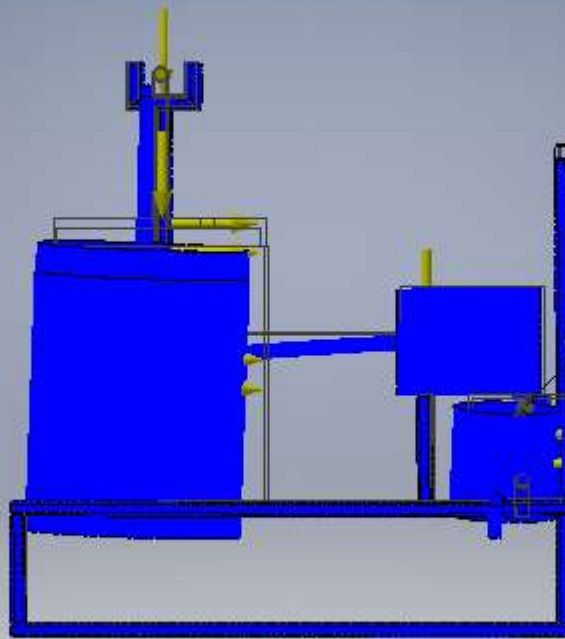

Min: 0 MPa

Max: 444,9 MPa

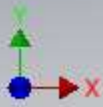

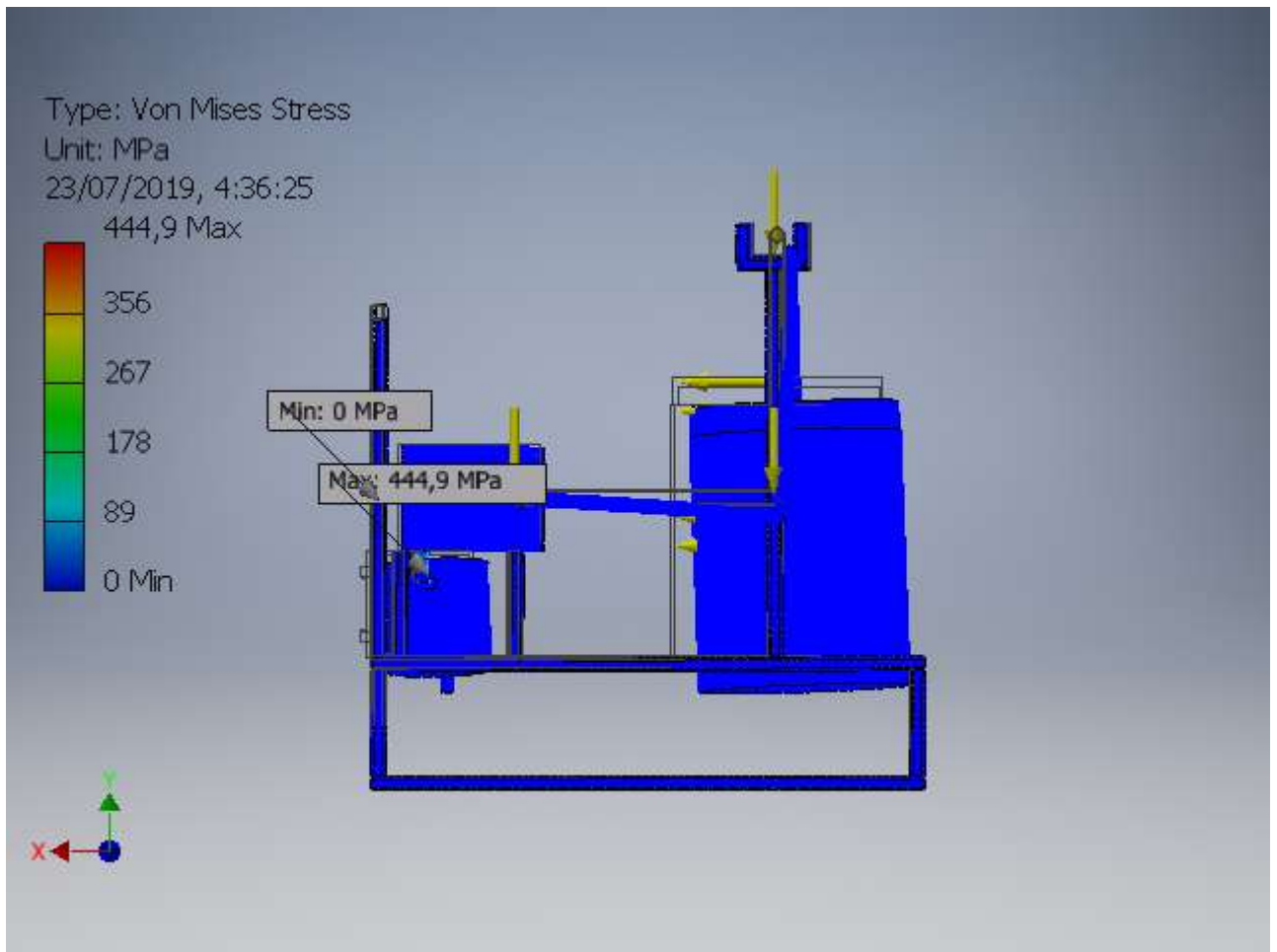

1st Principal Stress

Type: 1st Principal Stress

Unit: MPa

23/07/2019, 4:36:27

467,3 Max

346,9

226,6

106,3

-14,1

-134,4 Min

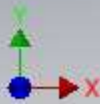
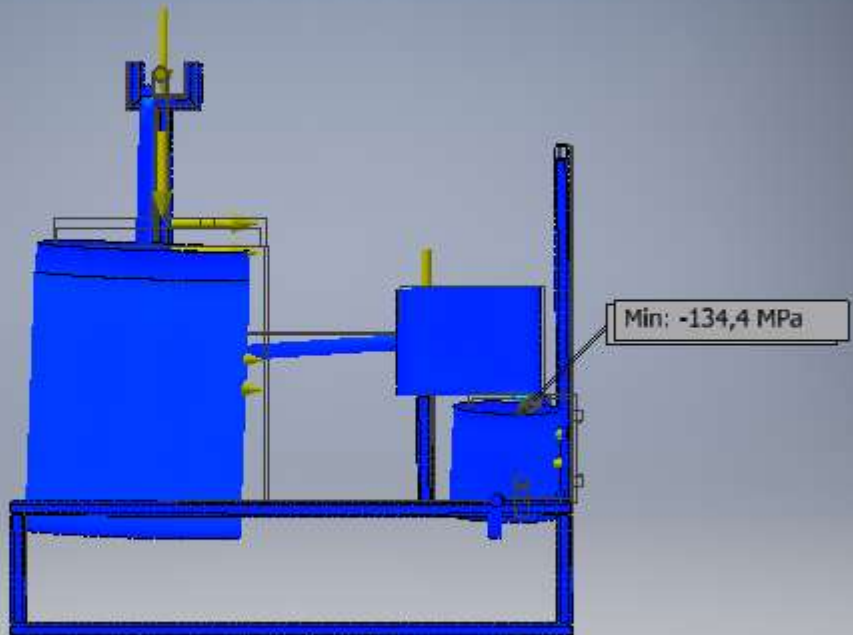

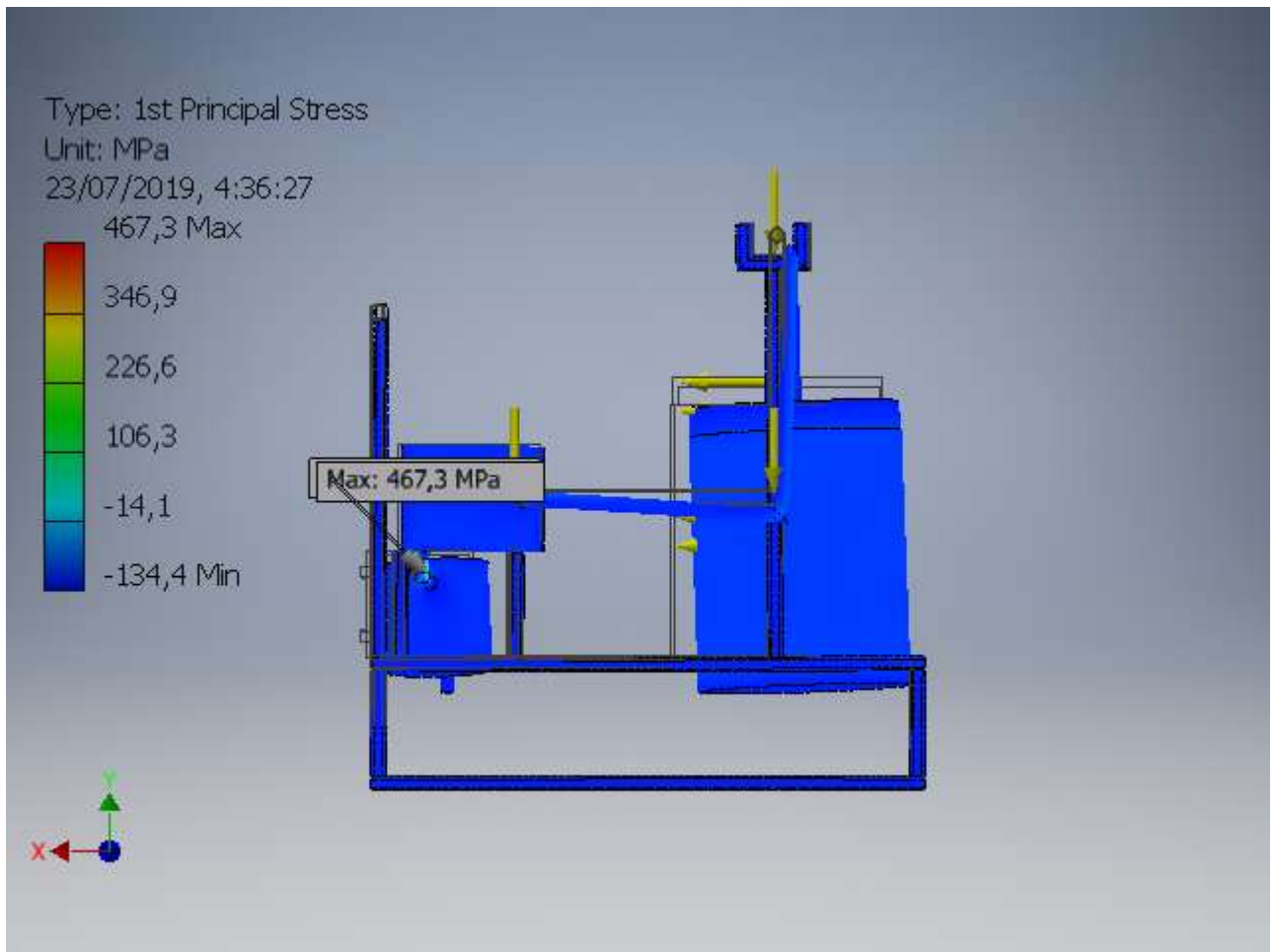

3rd Principal Stress

Type: 3rd Principal Stress

Unit: MPa

23/07/2019, 4:36:29

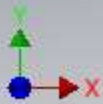
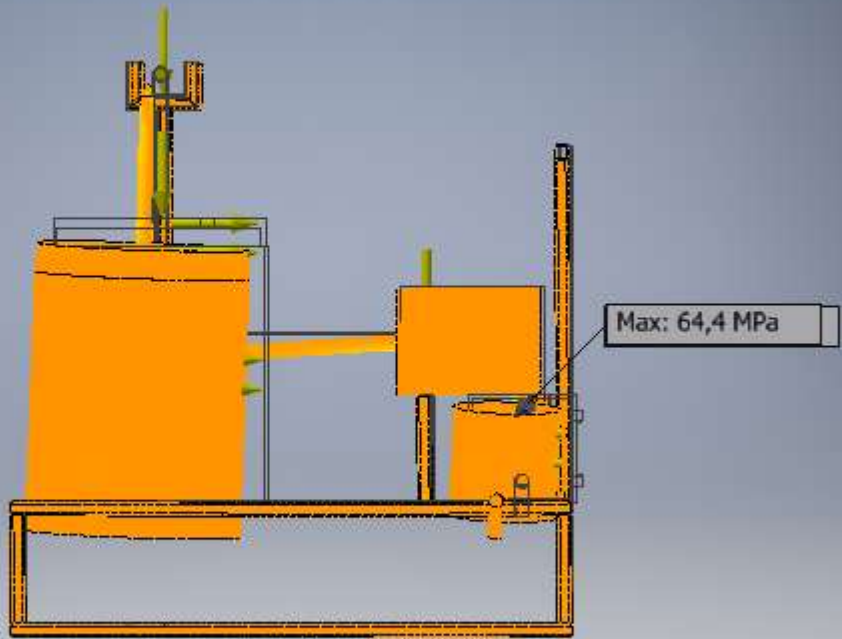

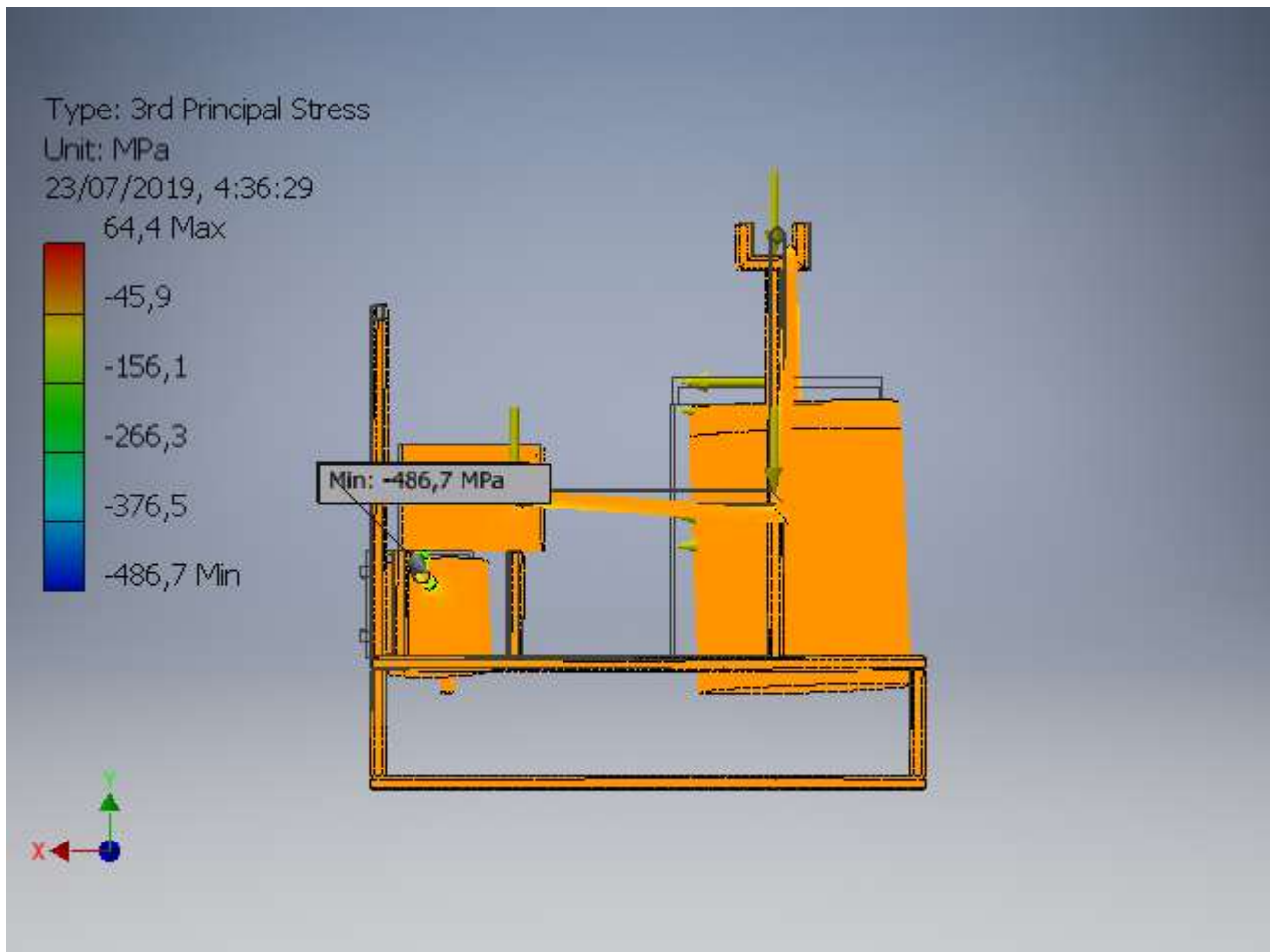

Displacement

Type: Displacement

Unit: mm

23/07/2019, 4:36:43

5,495 Max

4,396

3,297

2,198

1,099

0 Min

0 Min

0 Min

0 Min

0 Min

0 Min

0 Min

0 Min

0 Min

0 Min

0 Min

0 Min

0 Min

0 Min

0 Min

0 Min

0 Min

0 Min

0 Min

0 Min

0 Min

0 Min

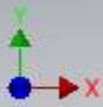
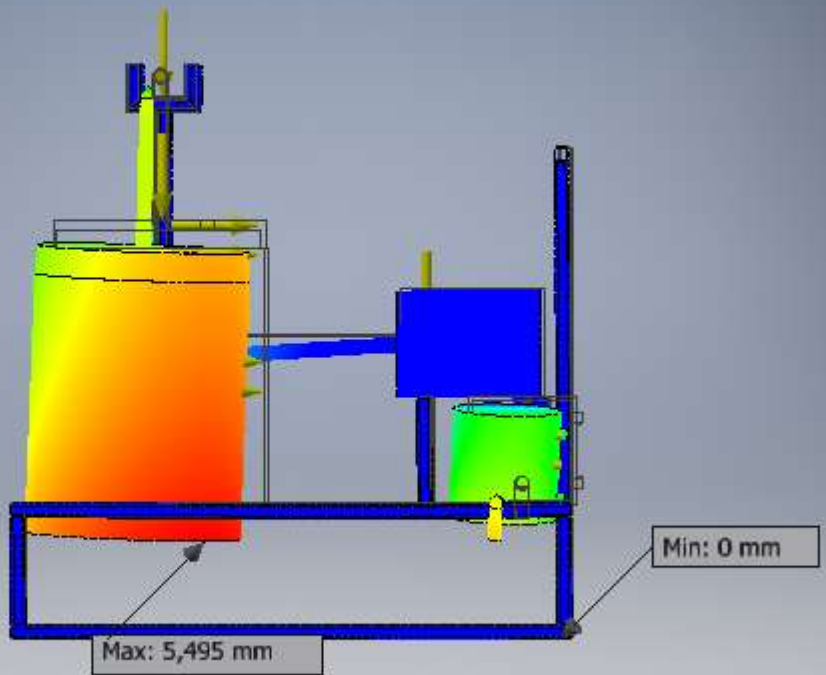

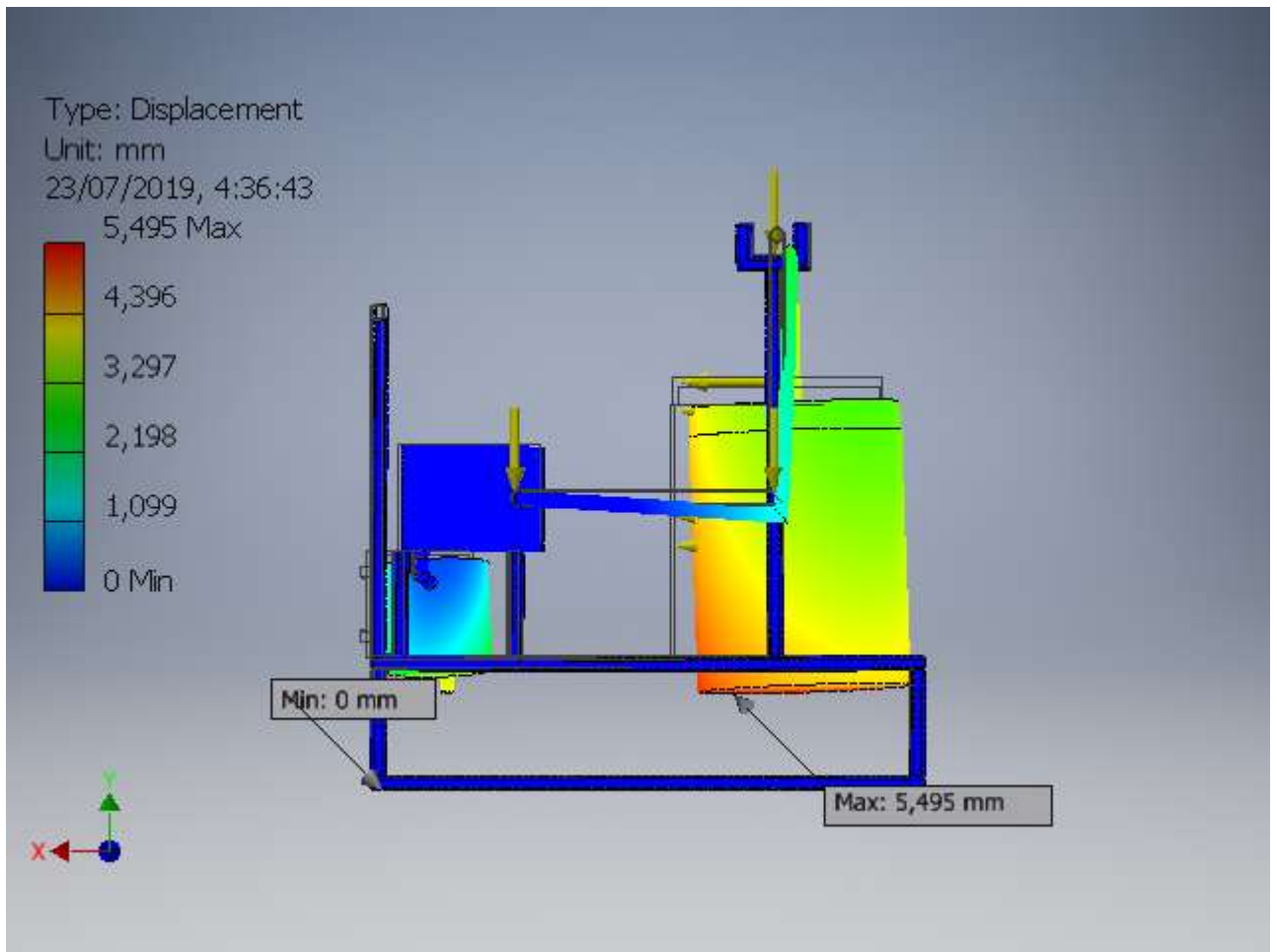

Safety Factor

Type: Safety Factor

Unit: ul

23/07/2019, 4:36:41

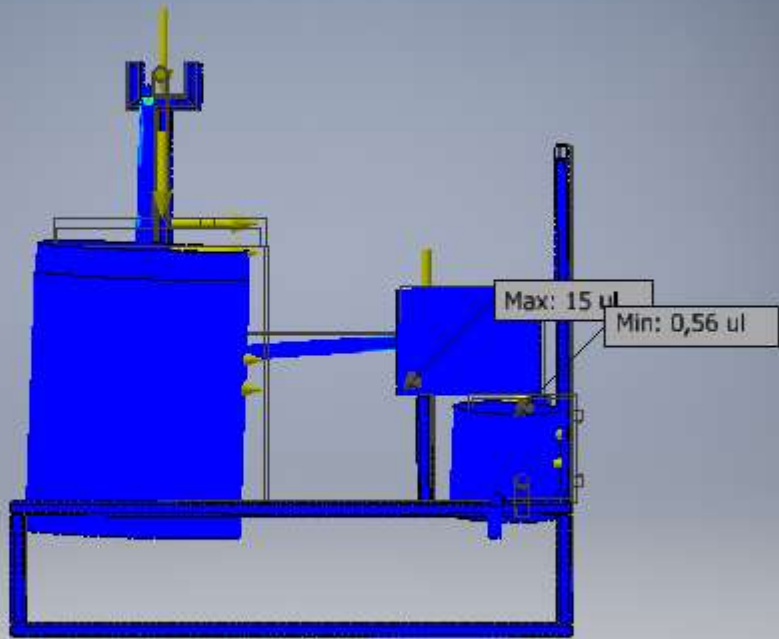

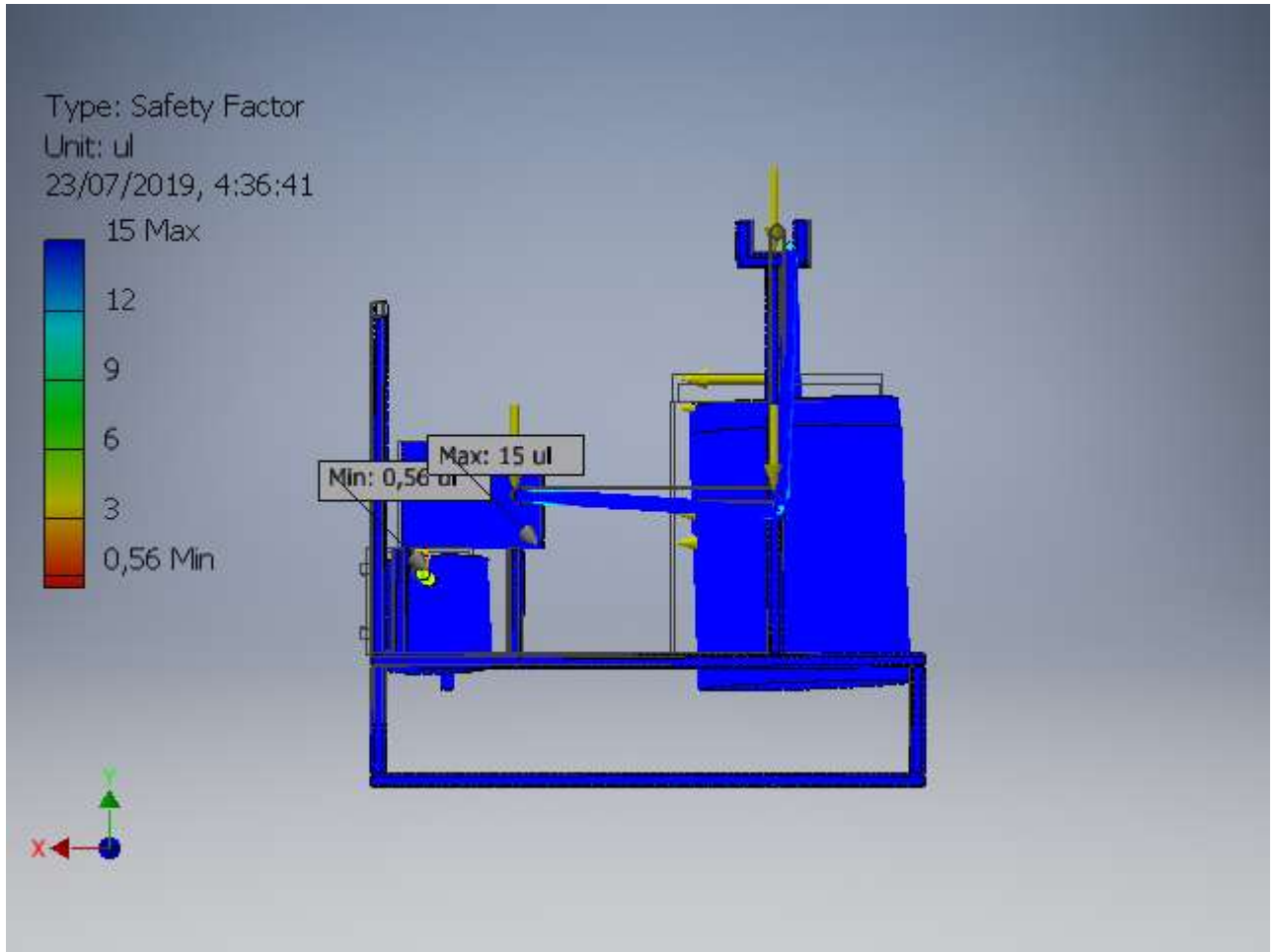

Stress XX

Type: Stress XX

Unit: MPa

23/07/2019, 4:36:31

149,9 Max

38,2

-73,5

-185,2

-296,9

-408,6 Min

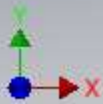
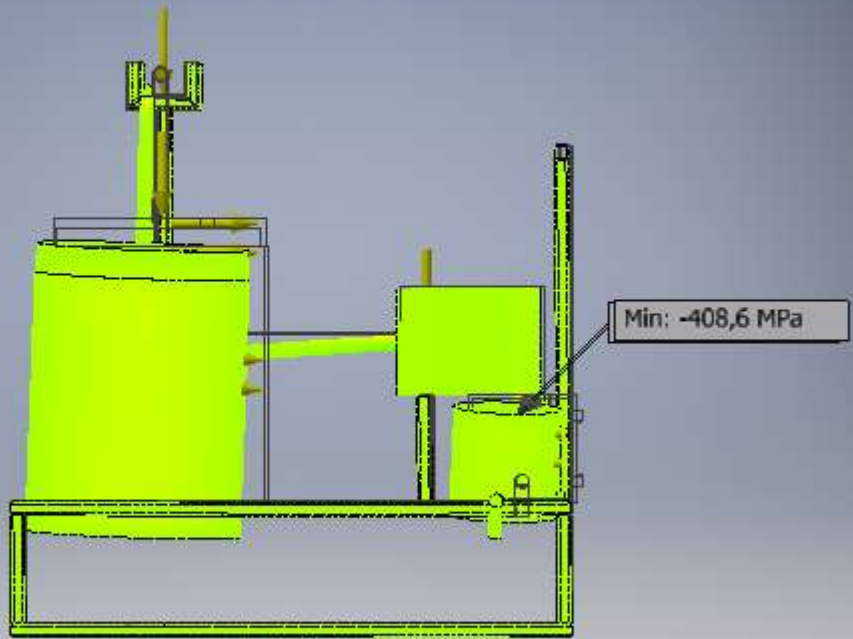

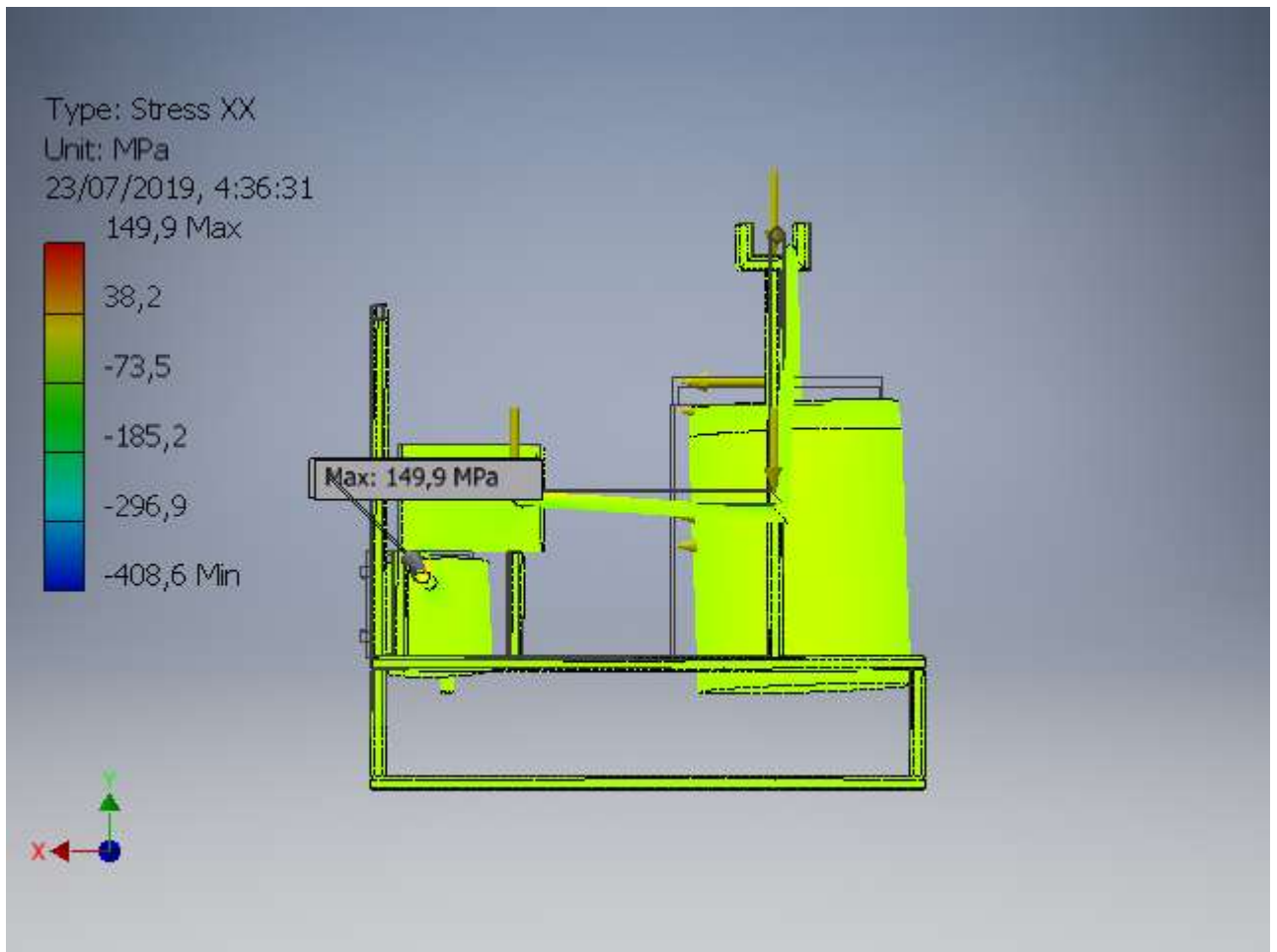

Stress XY

Type: Stress XY

Unit: MPa

23/07/2019, 4:36:32

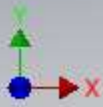
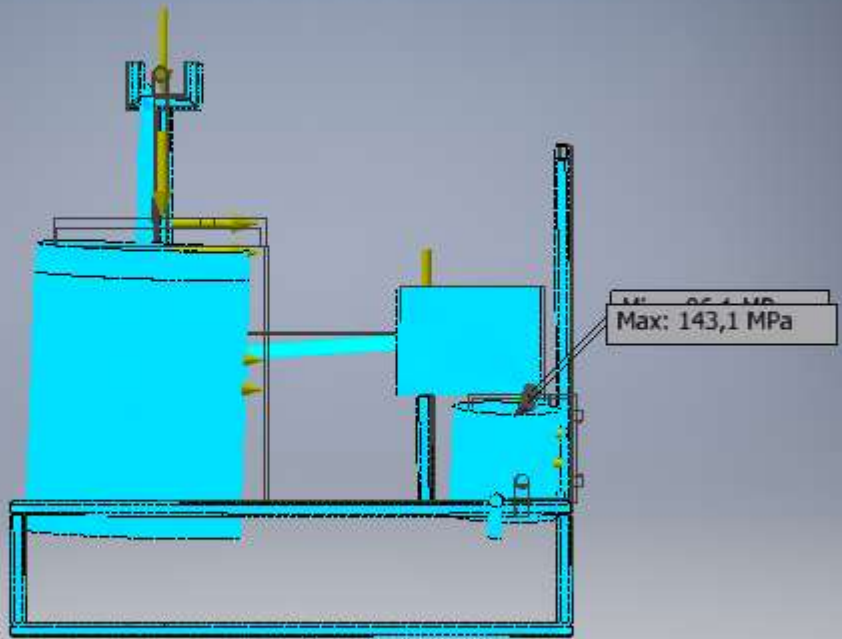
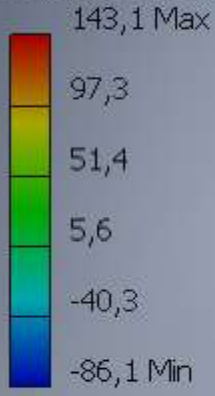

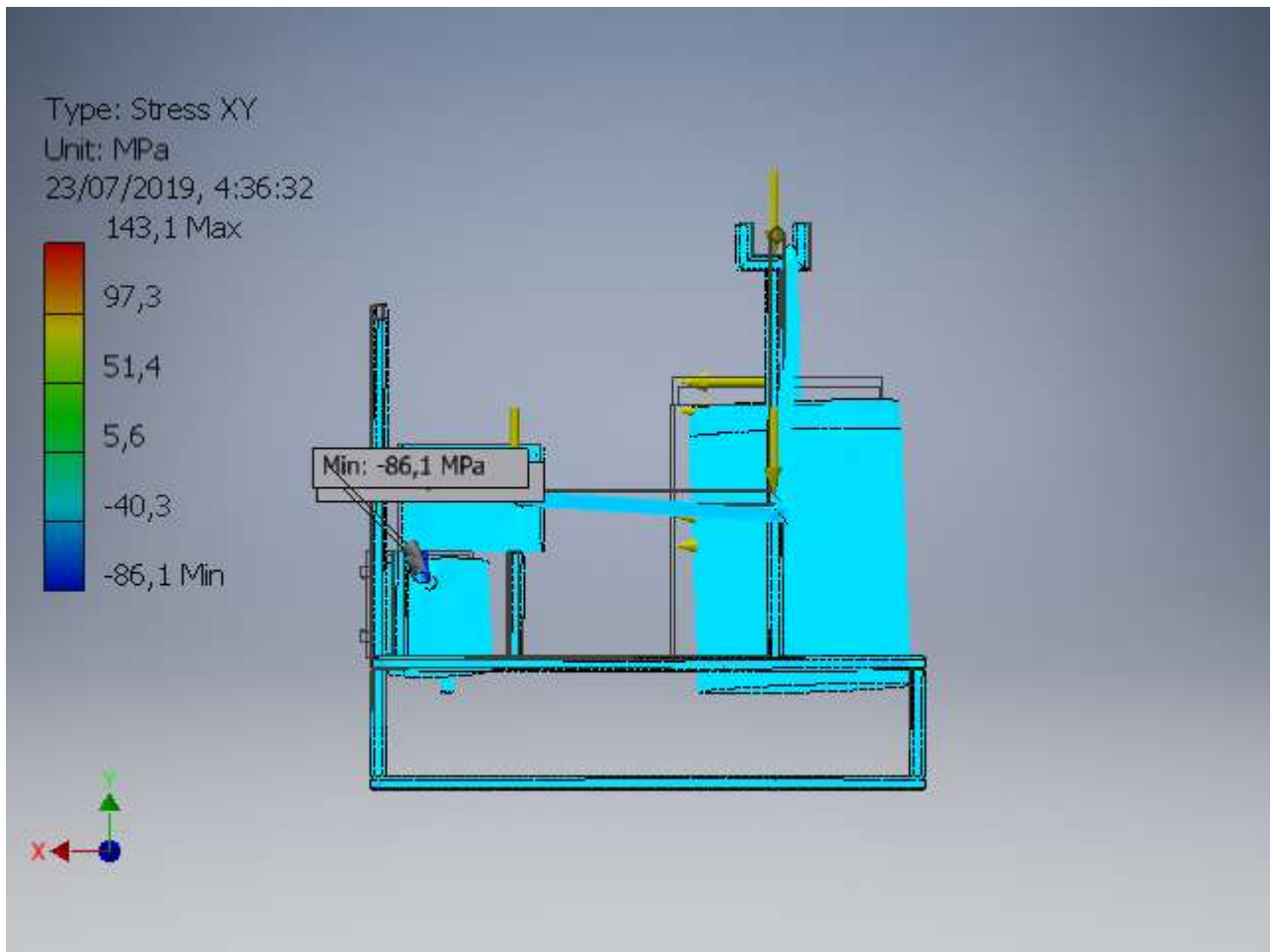

Stress XZ

Type: Stress XZ

Unit: MPa

23/07/2019, 4:36:34

109,1 Max

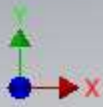
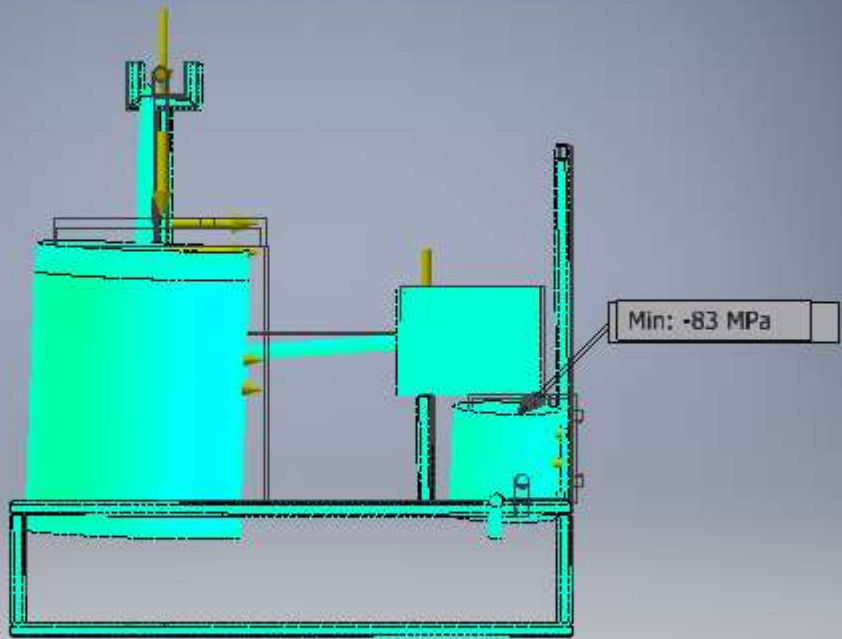

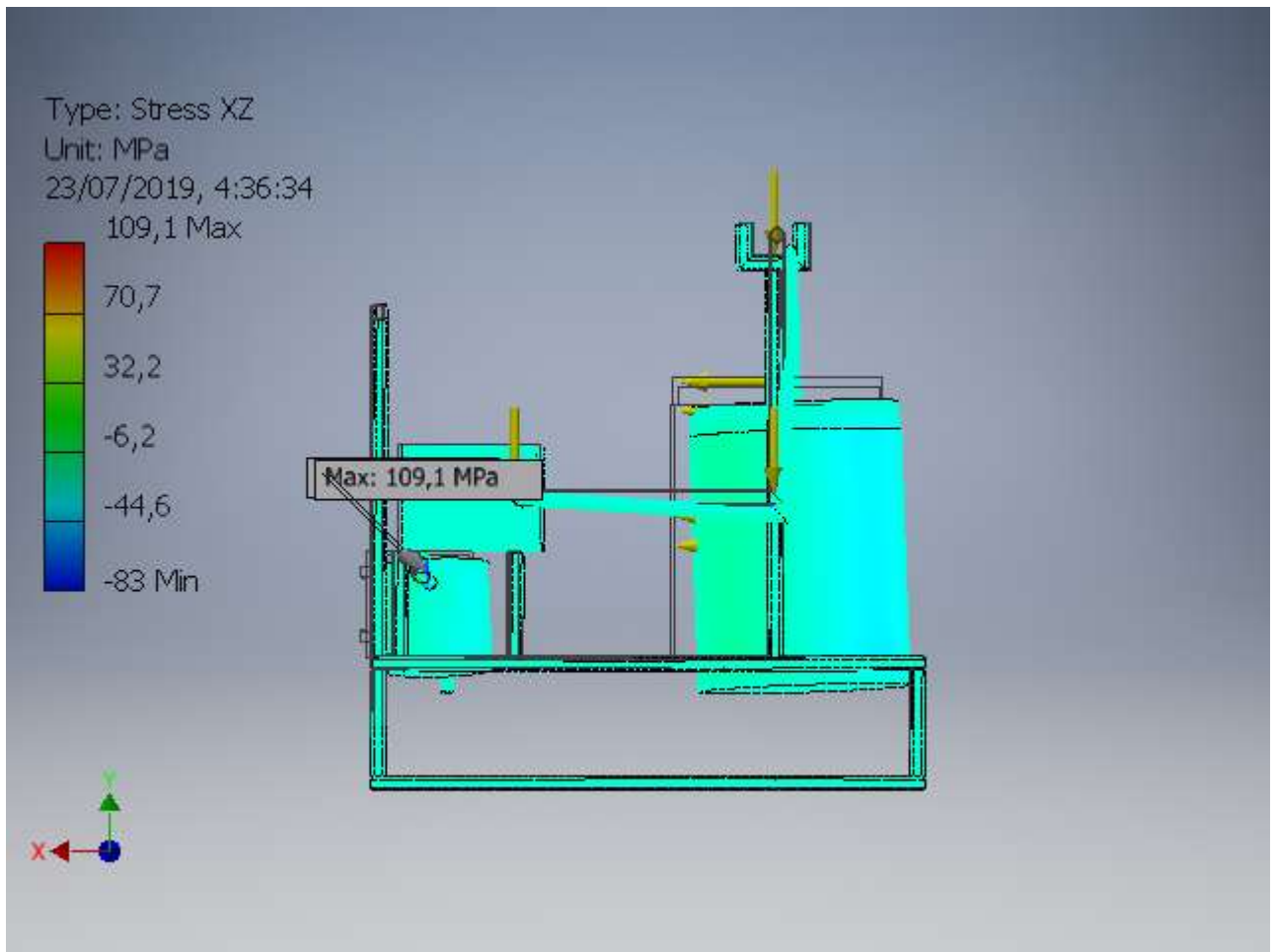

Stress YY

Type: Stress YY

Unit: MPa

23/07/2019, 4:36:36

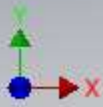
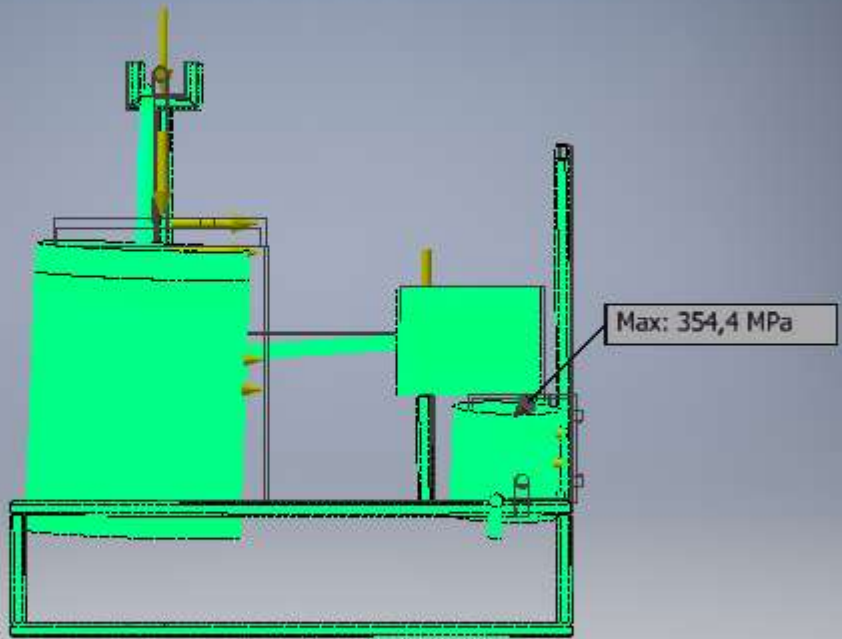
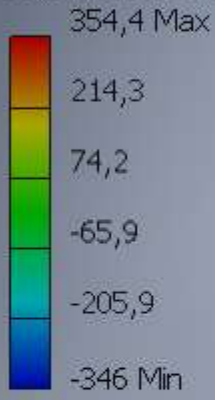

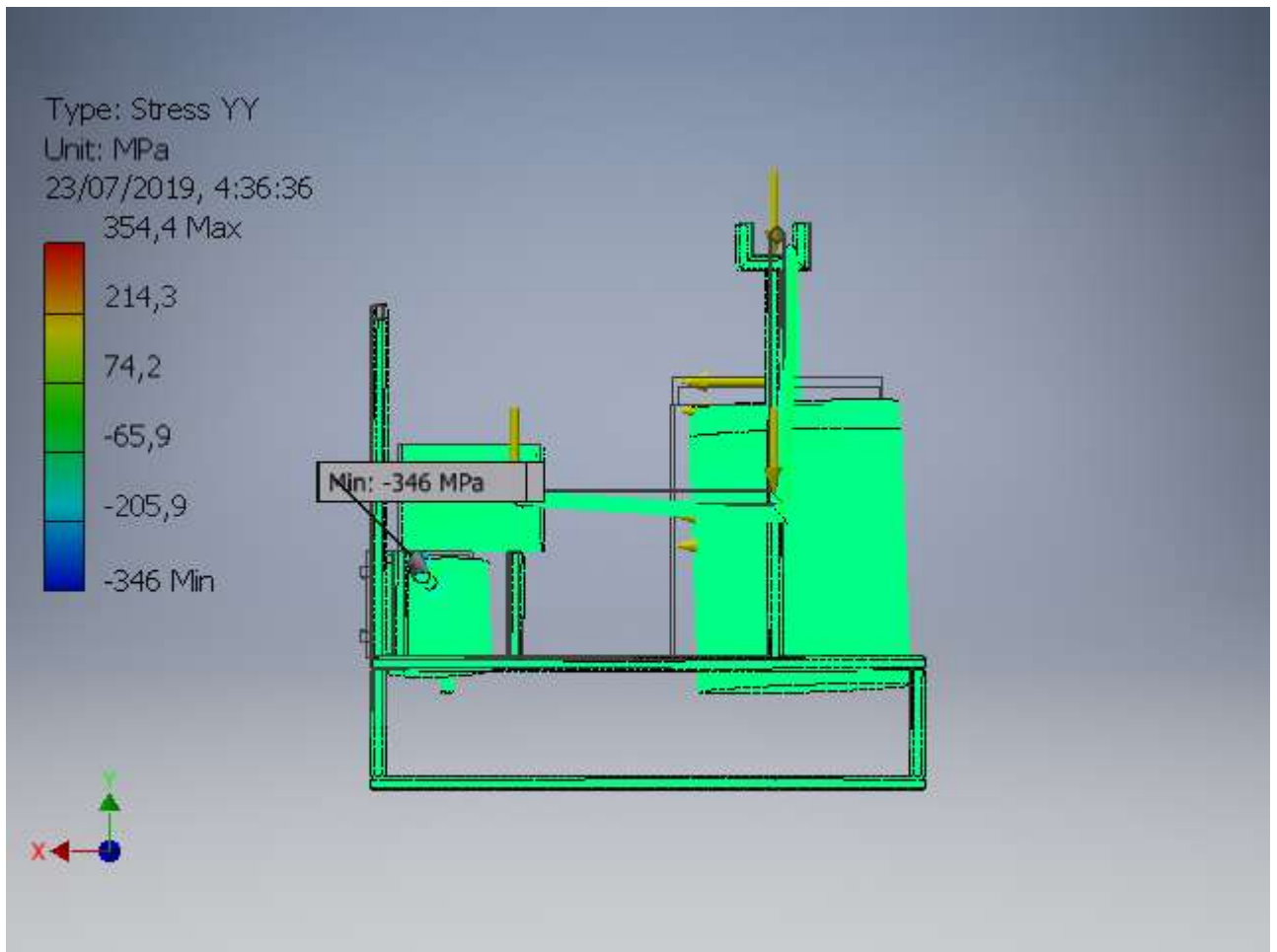

Stress YZ

Type: Stress YZ

Unit: MPa

23/07/2019, 4:36:38

210,8 Max

139,2

67,6

-4

-75,5

-147,1 Min

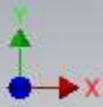
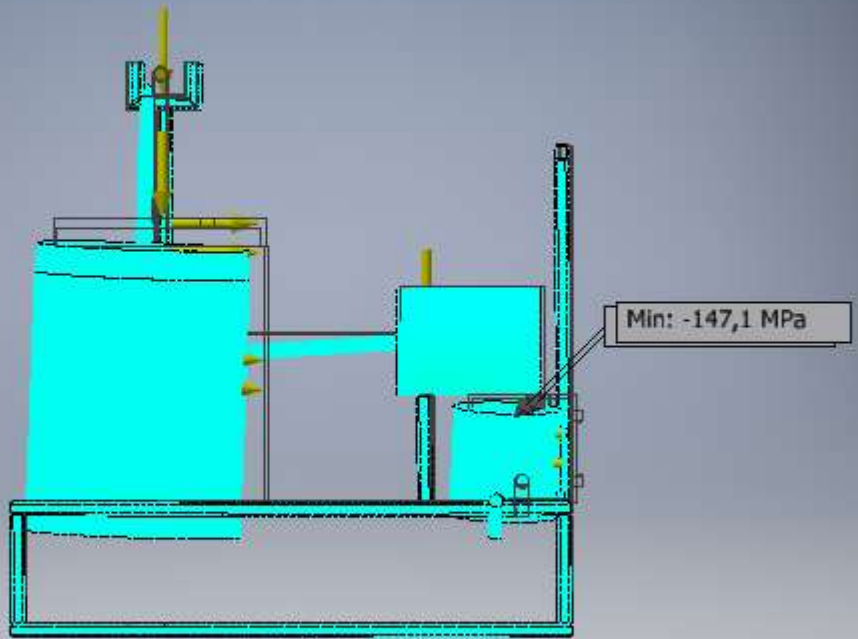

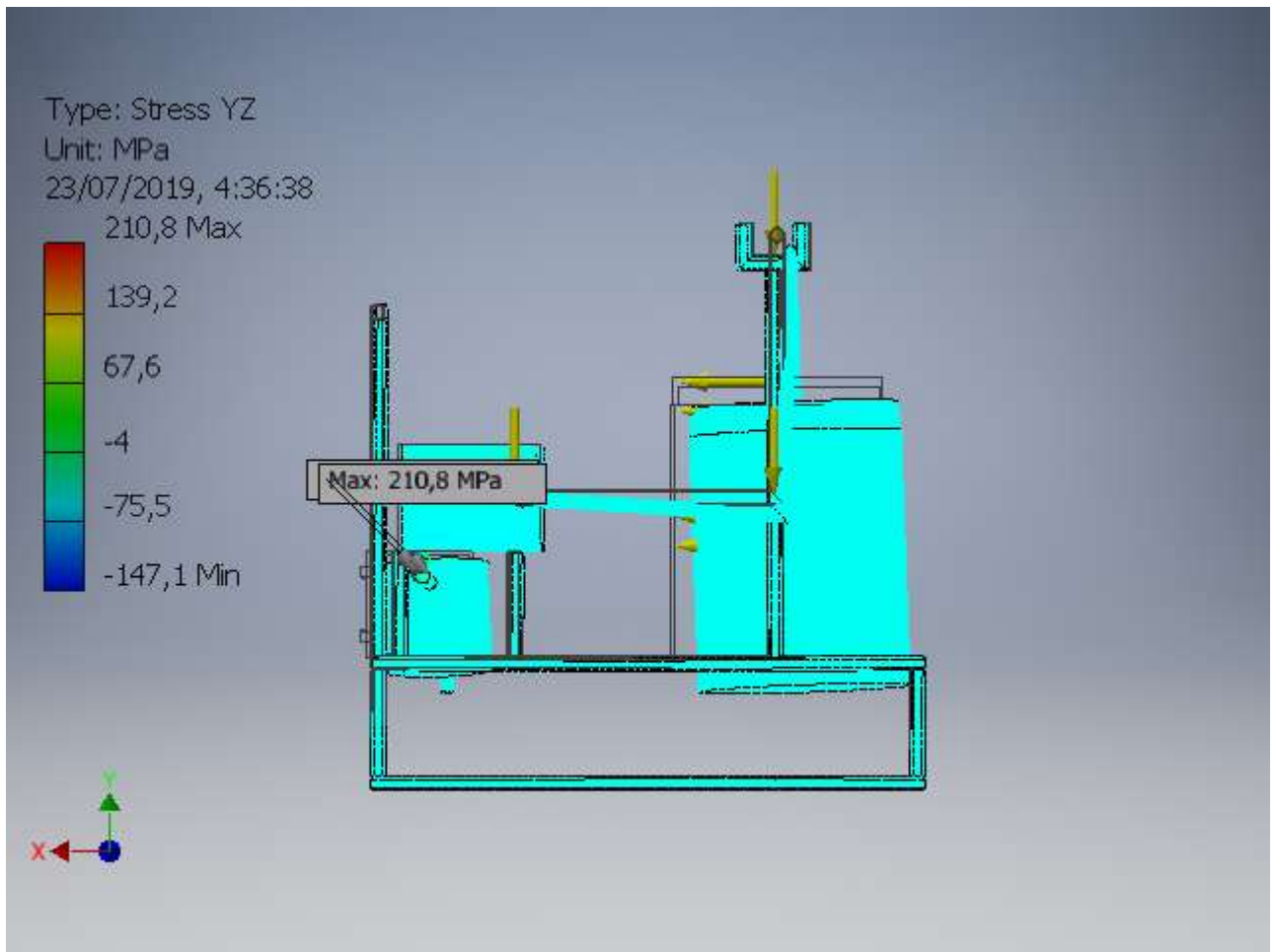

Stress ZZ

Type: Stress ZZ

Unit: MPa

23/07/2019, 4:36:39

307,7 Max

161,7

15,7

-130,3

-276,3

-422,3 Min

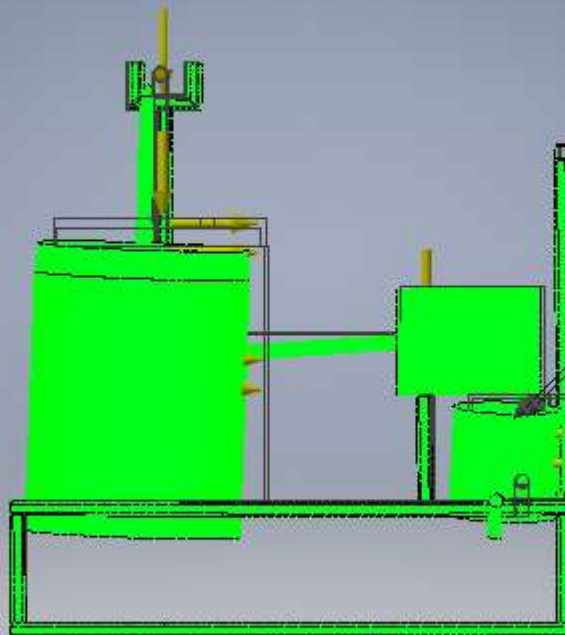

Max: 307,7 MPa

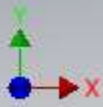

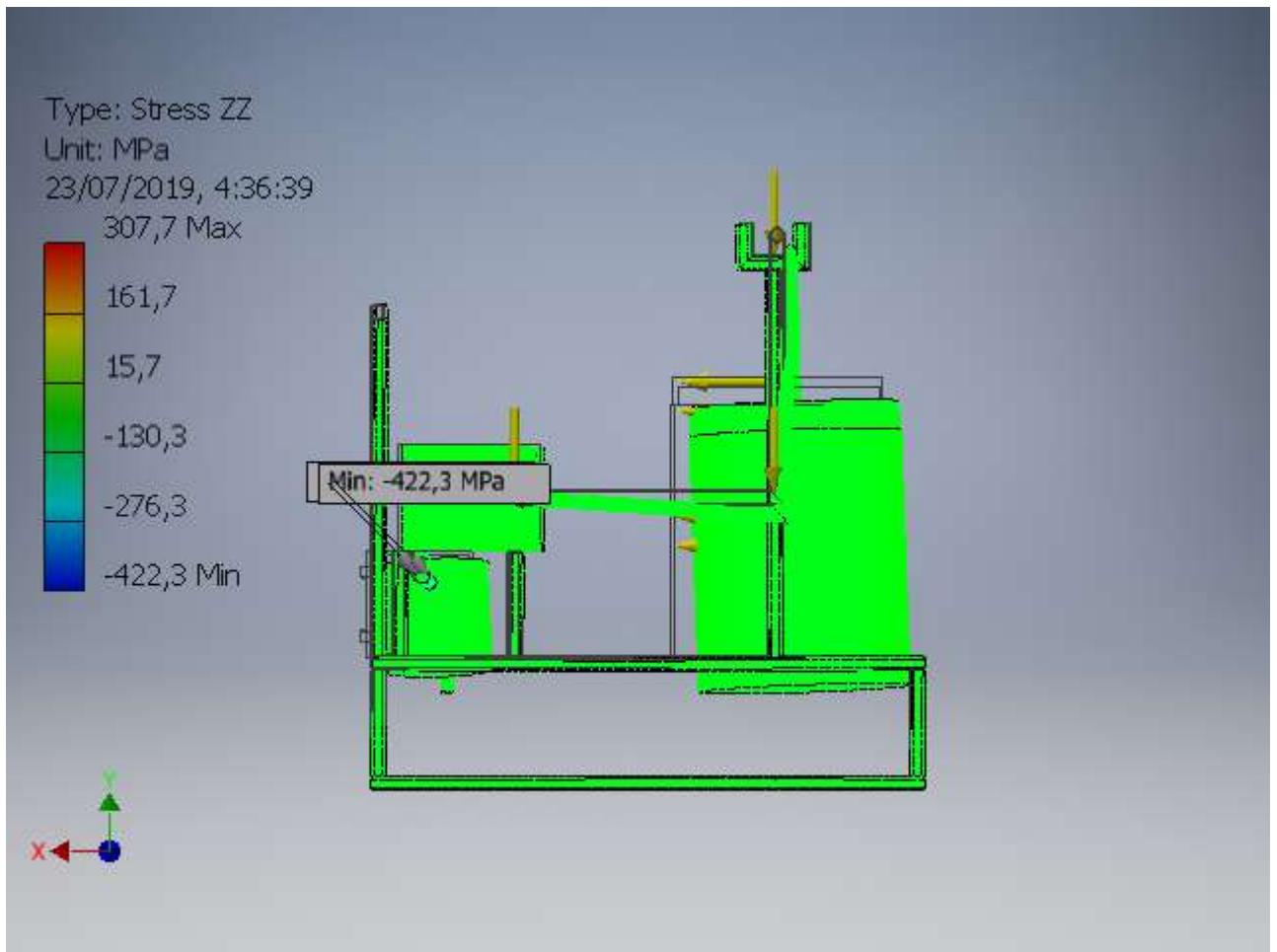

X Displacement

Type: X Displacement

Unit: mm

23/07/2019, 4:36:45

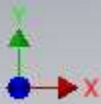
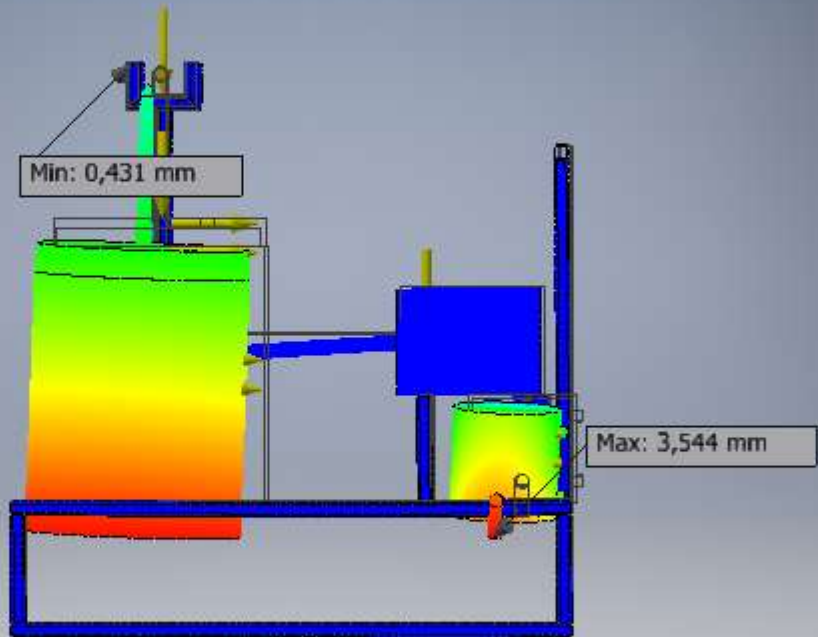
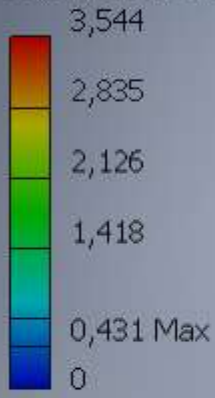

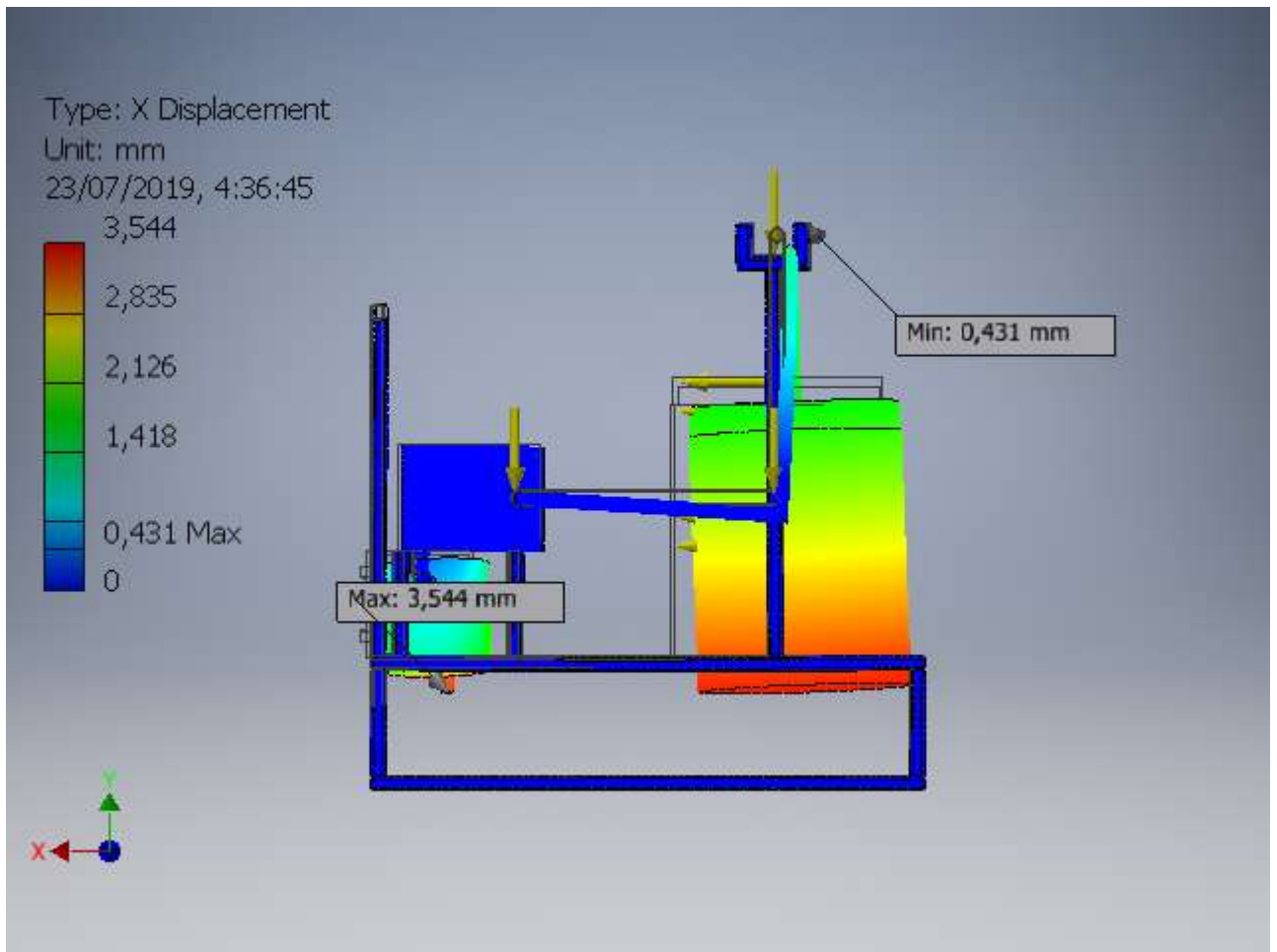

Y Displacement

Type: Y Displacement

Unit: mm

23/07/2019, 4:36:46

4,204

3,363

2,522

1,682

0,841

0,032 Max

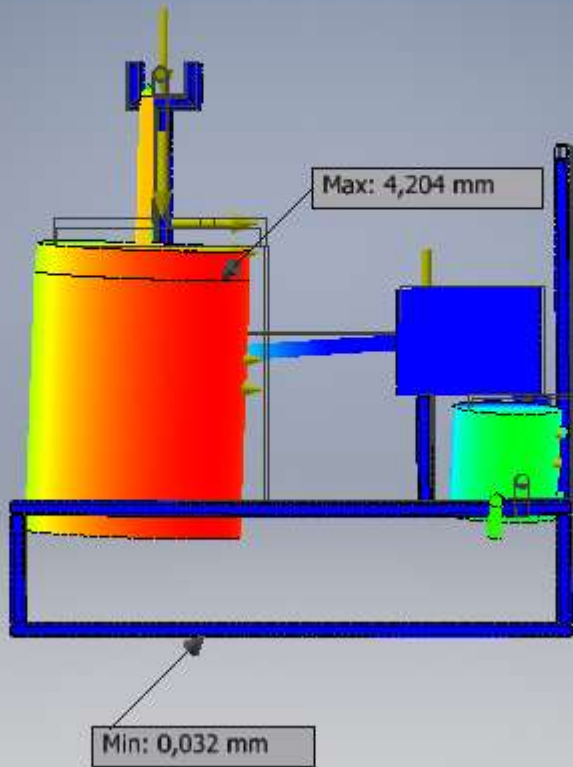

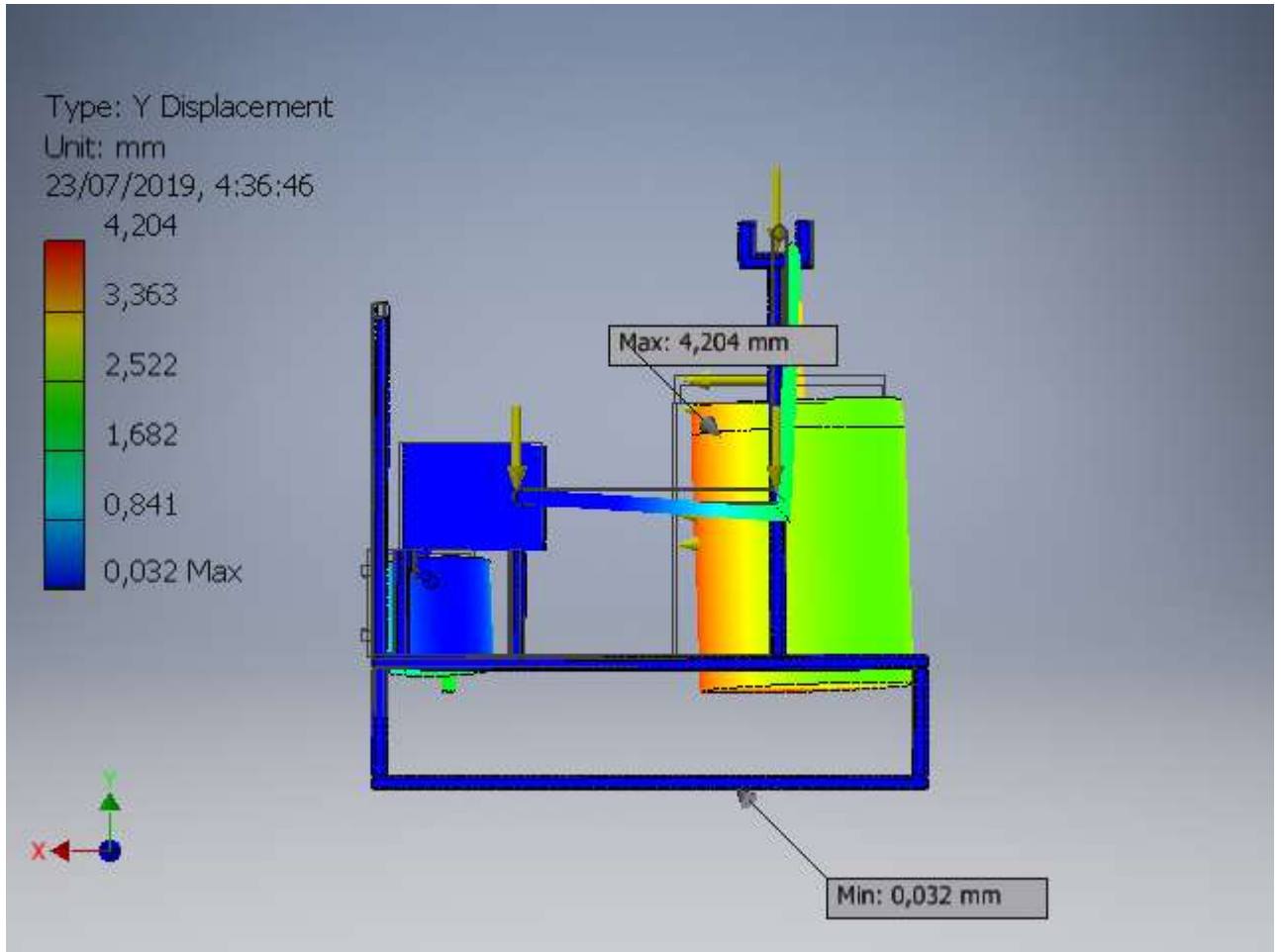

Z Displacement

Type: Z Displacement

Unit: mm

23/07/2019, 4:36:48

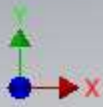
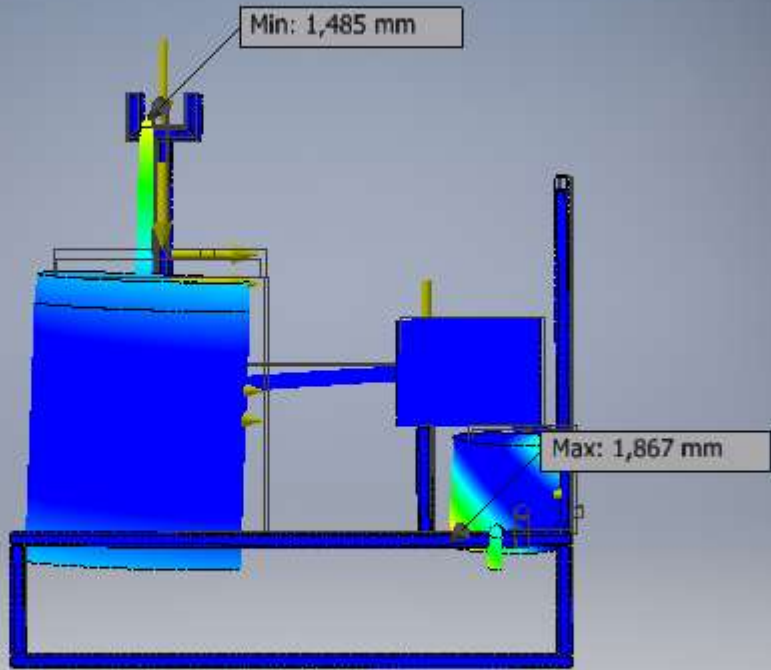
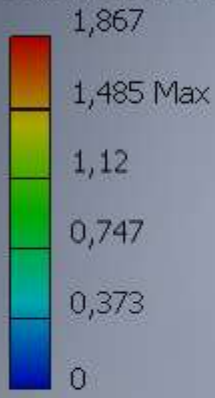

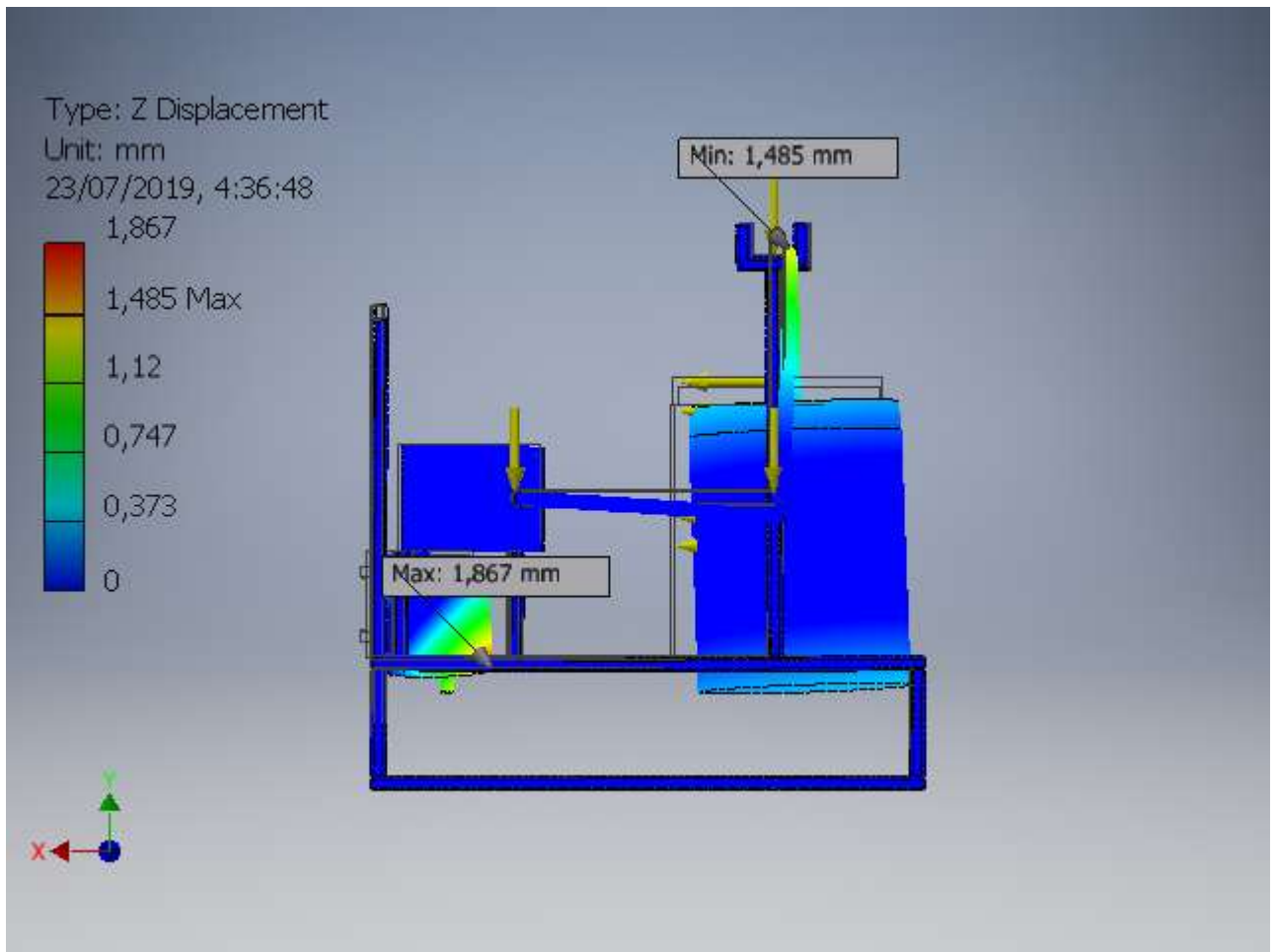

Equivalent Strain

Type: Equivalent Strain

Unit: ul

23/07/2019, 4:36:50

0,002075 Max

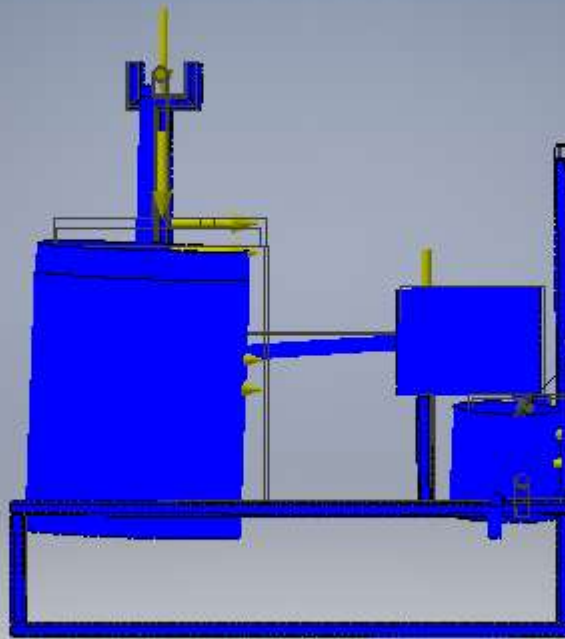
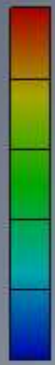

Min: 0 ul

Max: 0,002075 ul

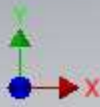

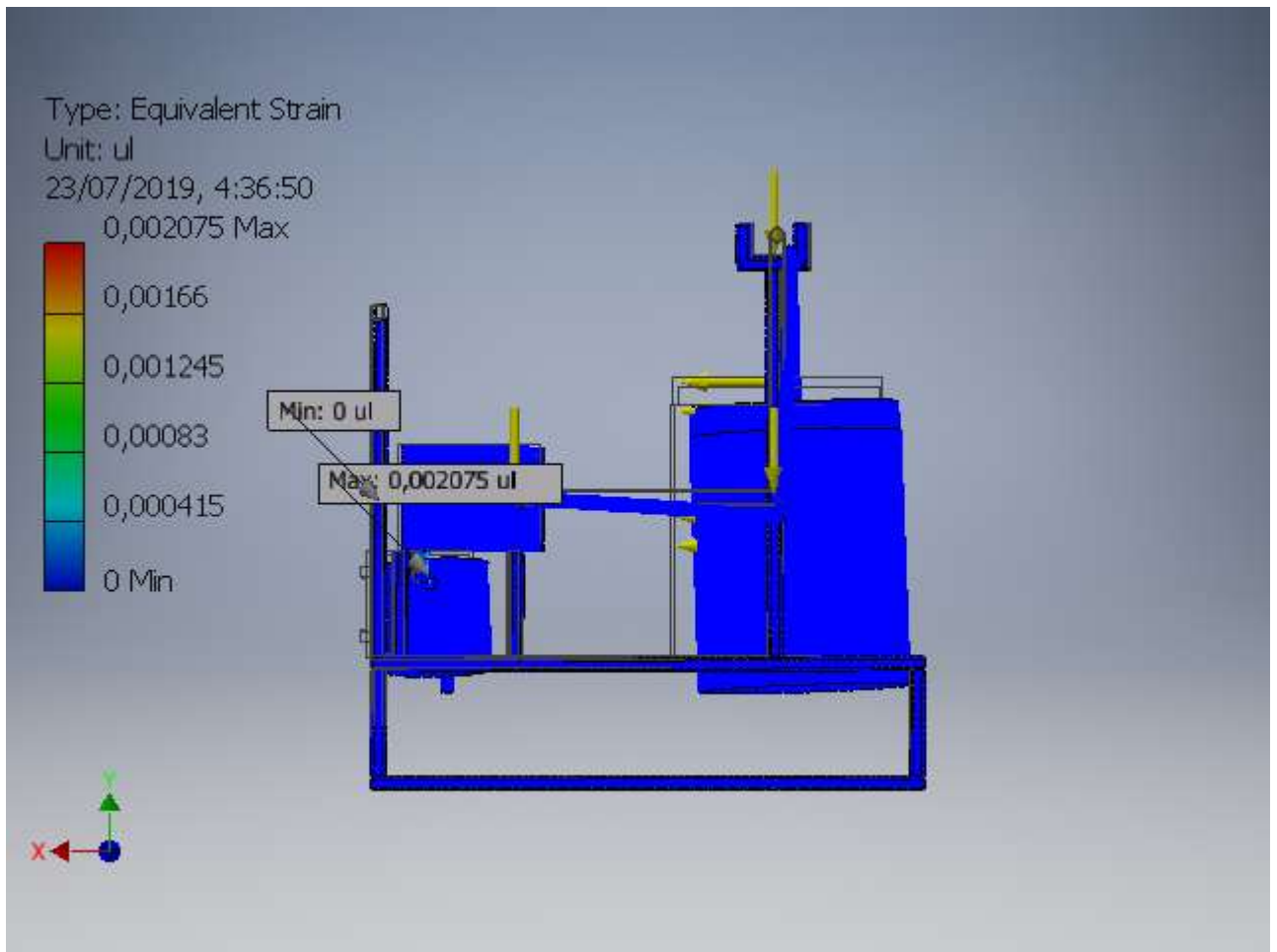

1st Principal Strain

Type: 1st Principal Strain

Unit: ul

23/07/2019, 4:36:52

0,002022 Max

0,001613

0,001204

0,000795

0,000386

-0,000024 Min

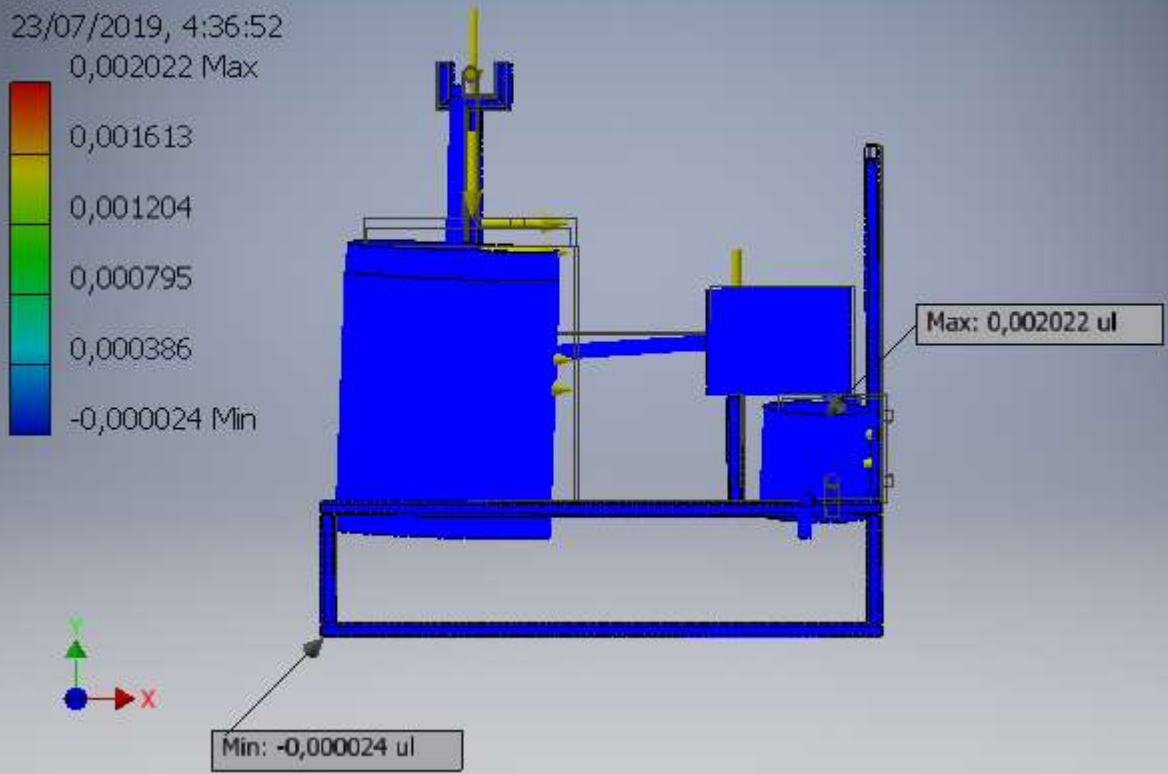

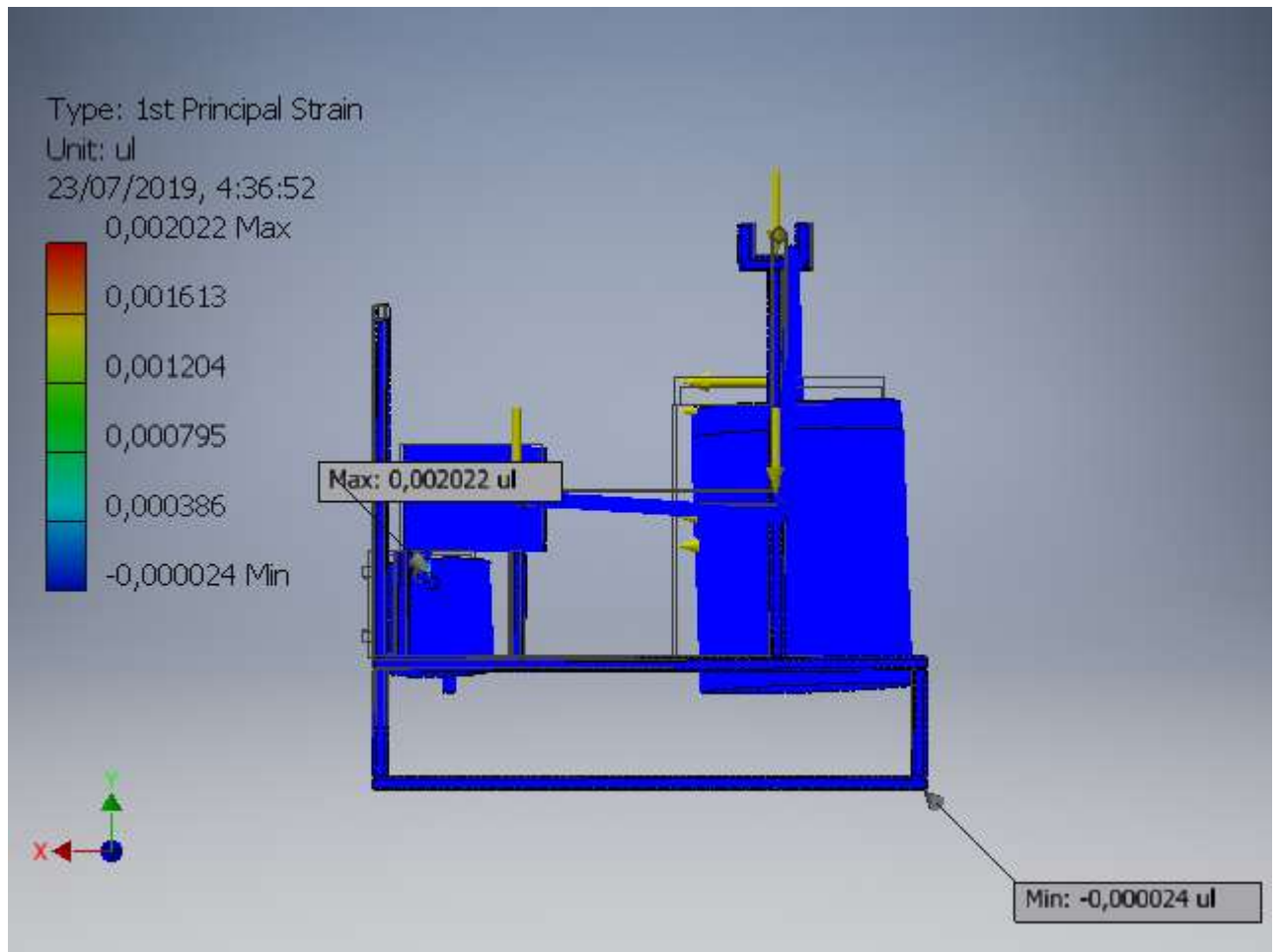

3rd Principal Strain

Type: 3rd Principal Strain

Unit: ul

23/07/2019, 4:36:54

0,000043 Max

-0,000444

-0,00093

-0,001417

-0,001903

-0,00239 Min

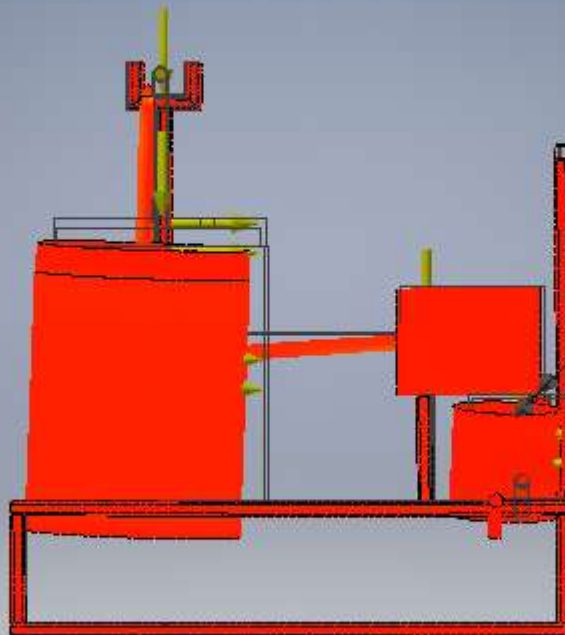

Max: 0,000043 ul
Min: -0,00239 ul

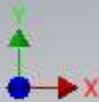

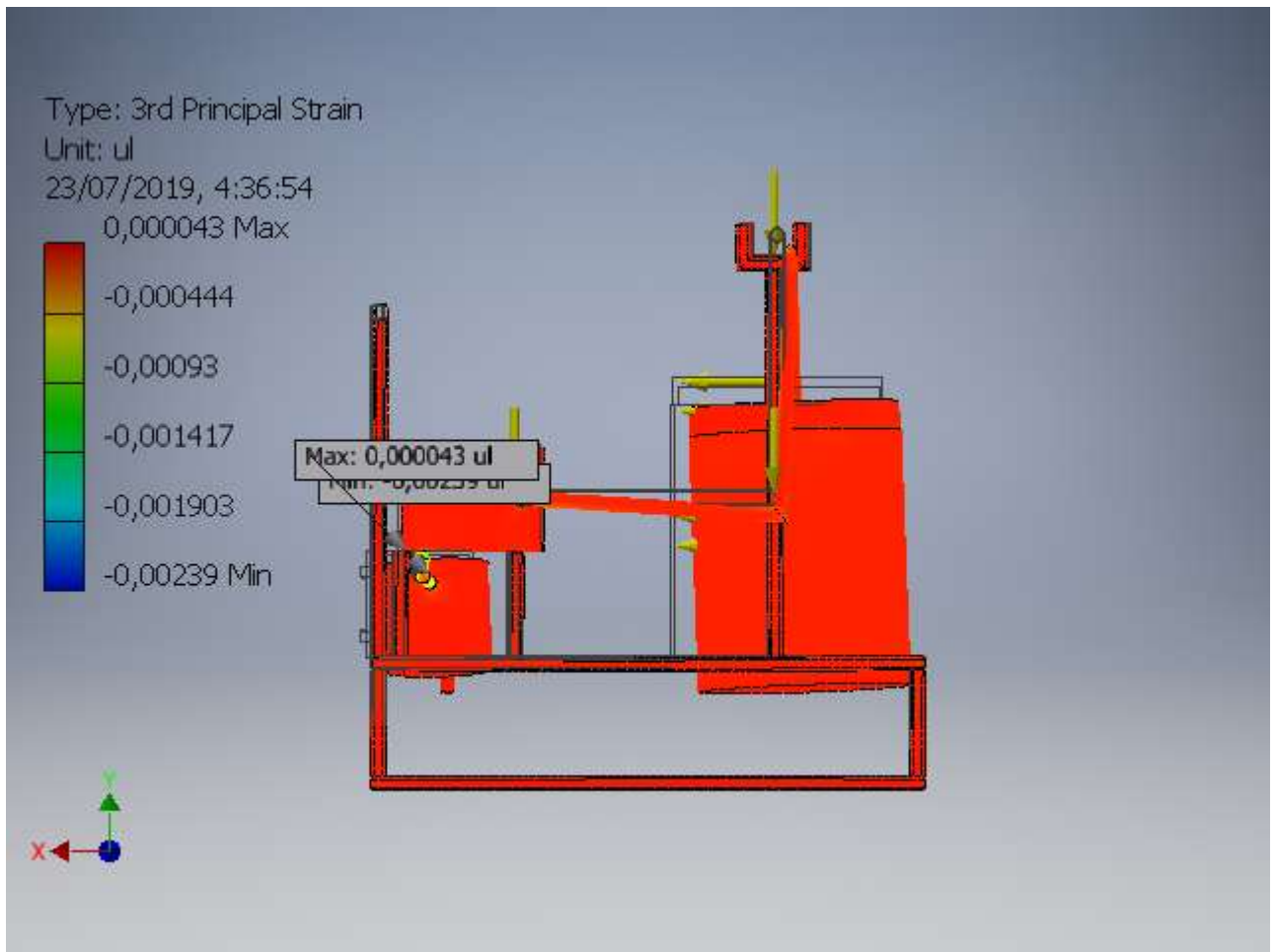

Strain XX

Type: Strain XX

Unit: ul

23/07/2019, 4:36:56

0,000824 Max

0,000354

-0,000115

-0,000585

-0,001055

-0,001525 Min

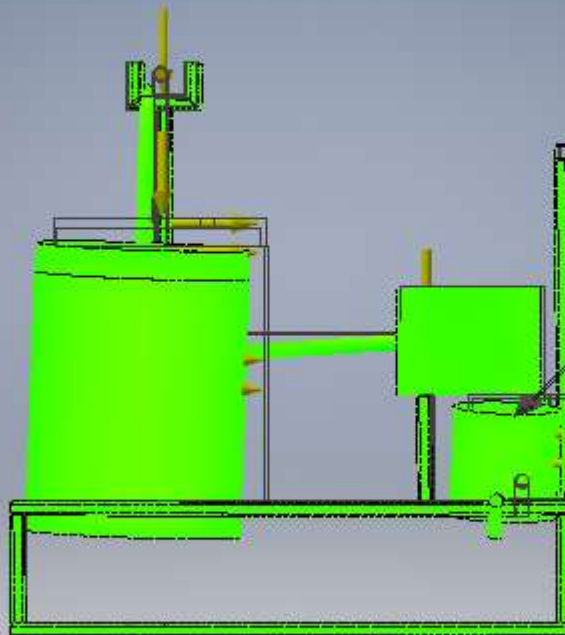

Min: -0,001525 ul

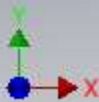

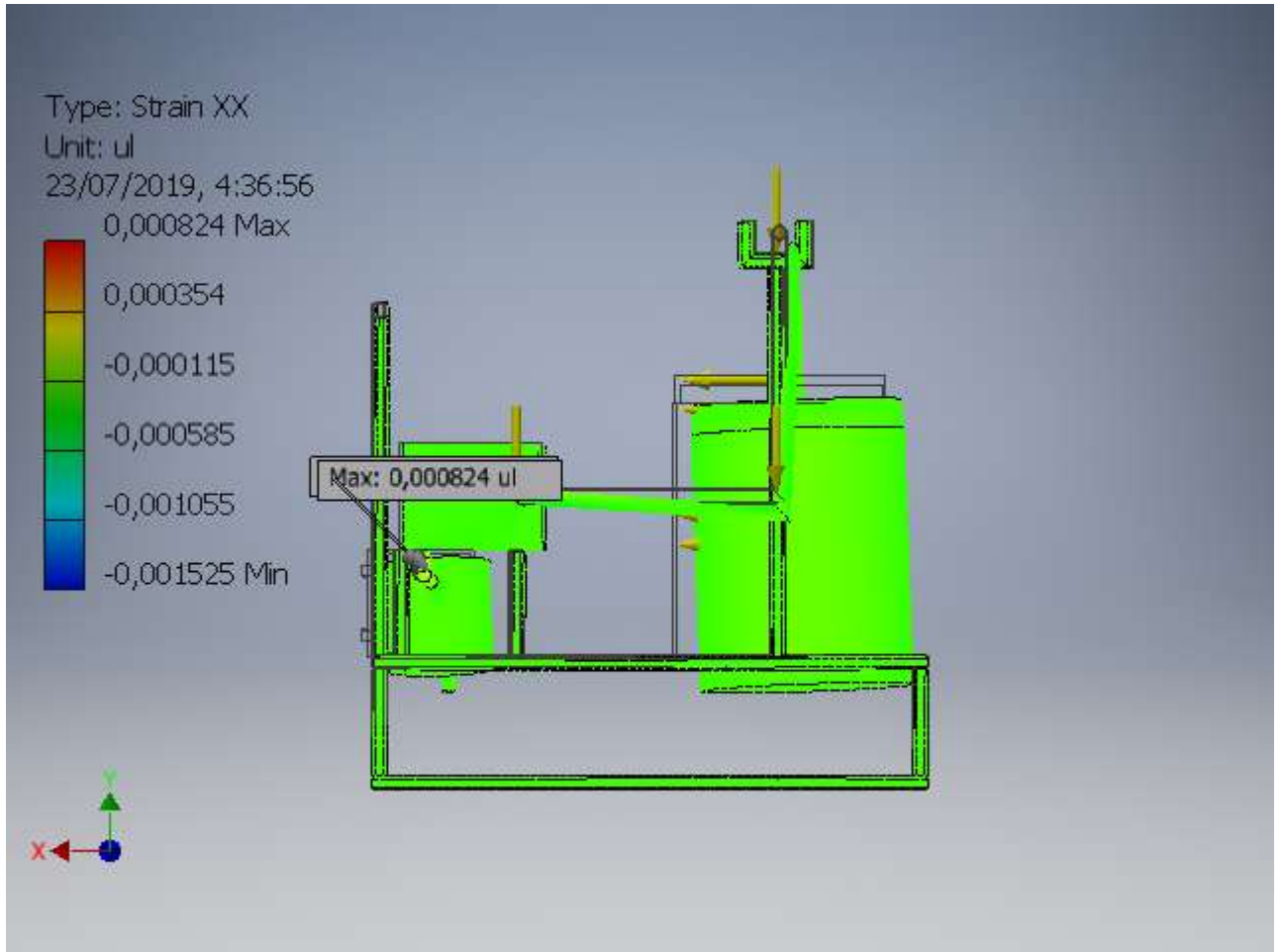

Strain XY

Type: Strain XY

Unit: ul

23/07/2019, 4:36:57

9,642e-004 Max

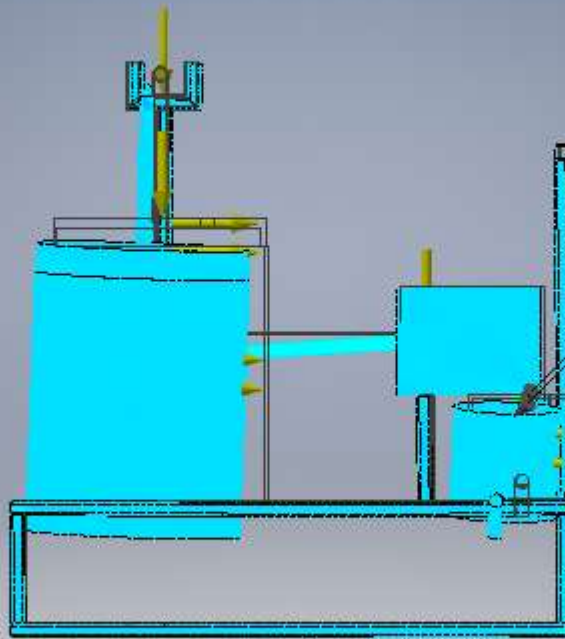

Max: 9,642e-004 ul

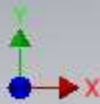

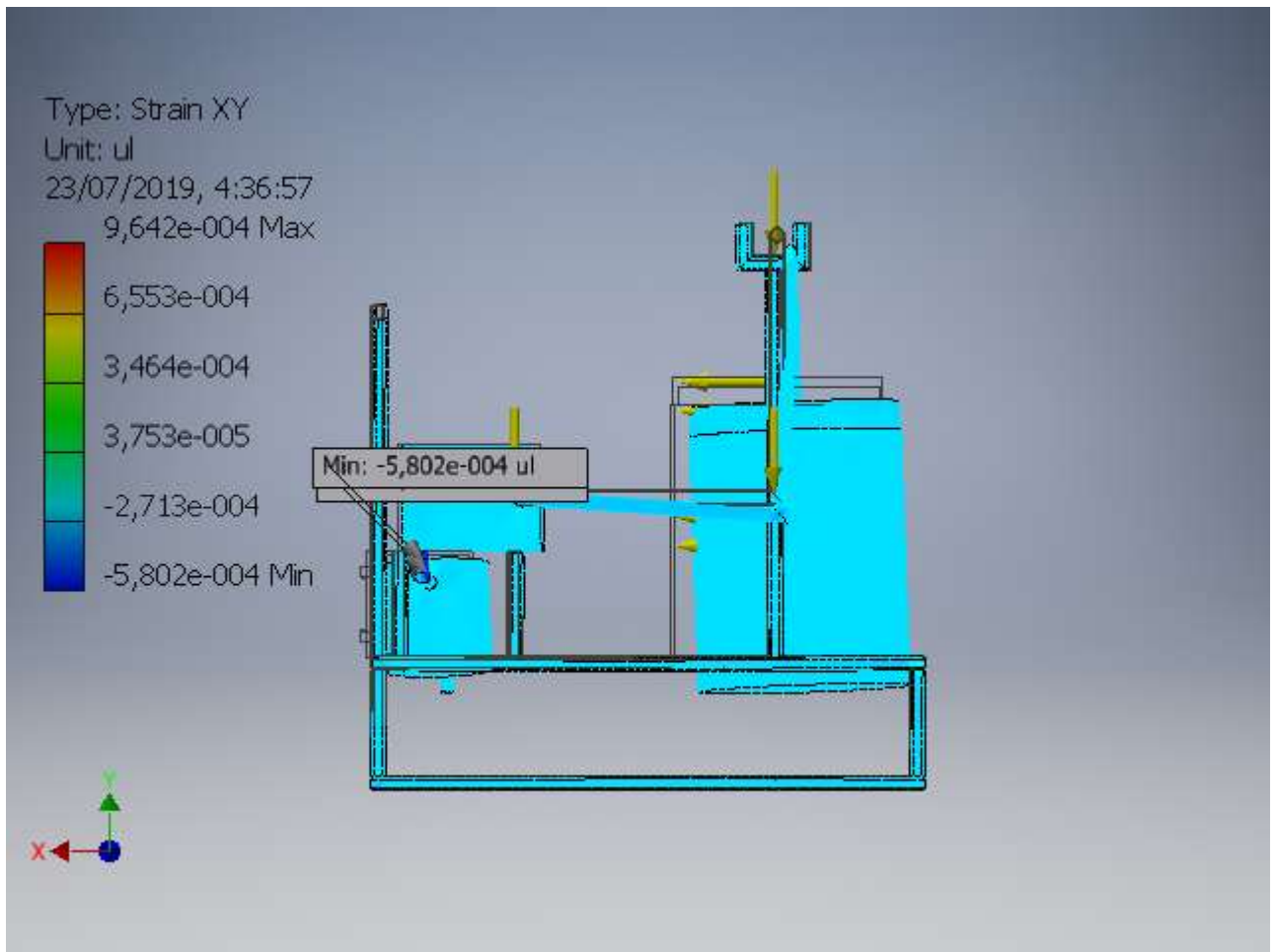

Strain XZ

Type: Strain XZ

Unit: ul

23/07/2019, 4:36:59

7,348e-004 Max

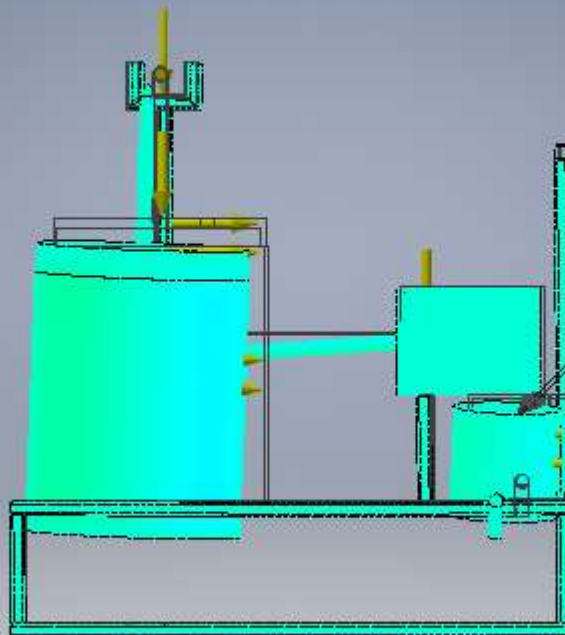
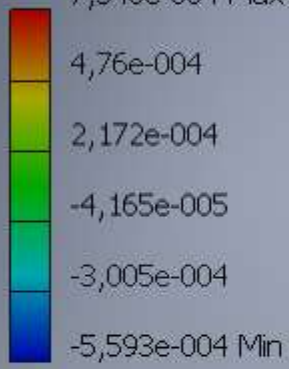

Min: -5,593e-004 ul

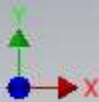

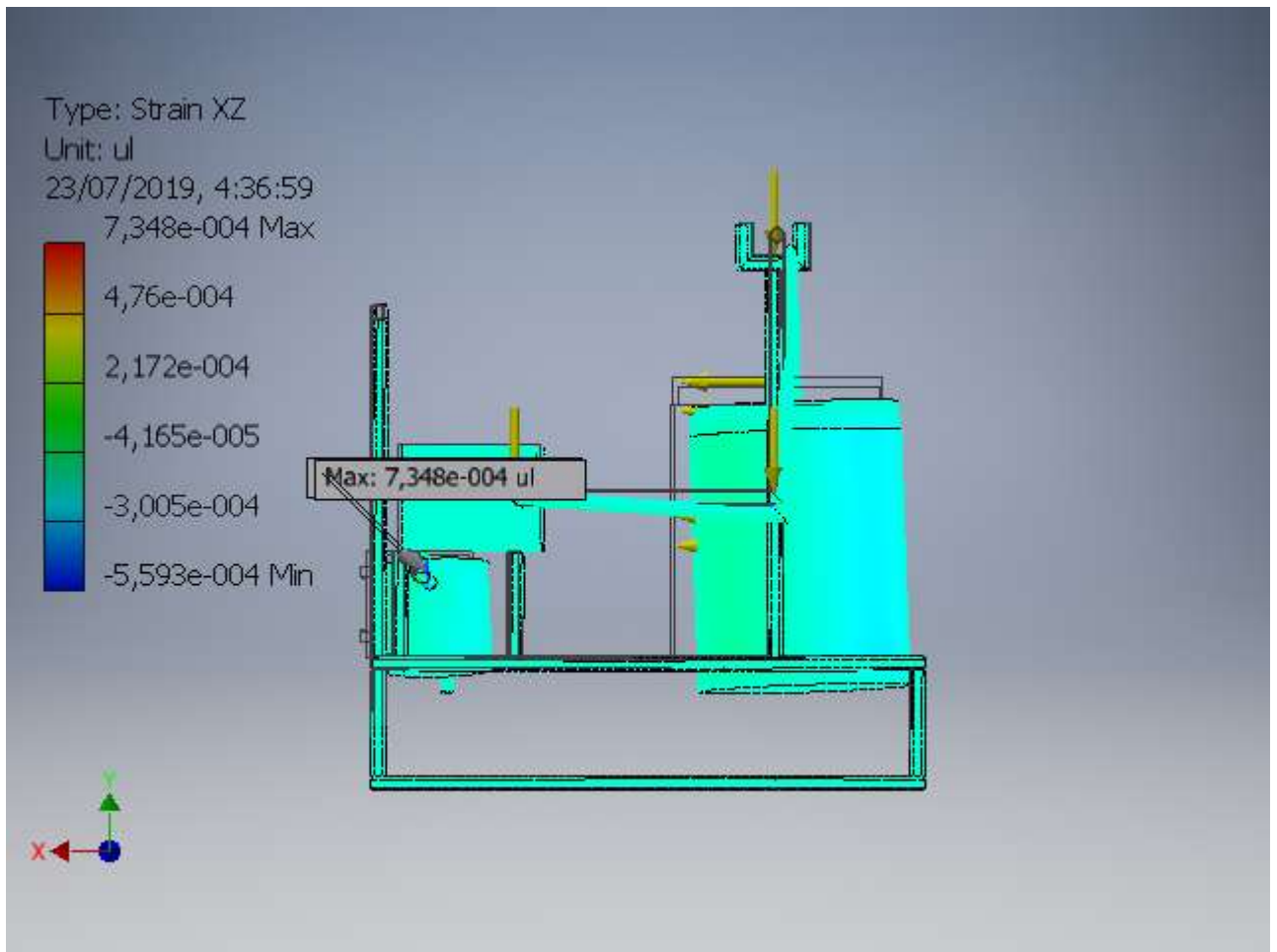

Strain YY

Type: Strain YY

Unit: ul

23/07/2019, 4:37:01

0,001381 Max

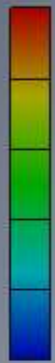

0,000804

0,000228

-0,000349

-0,000926

-0,001503 Min

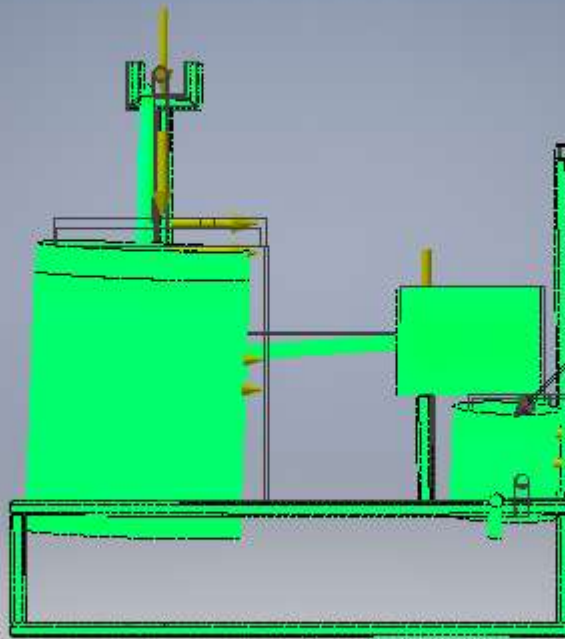

Max: 0,001381 ul

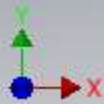

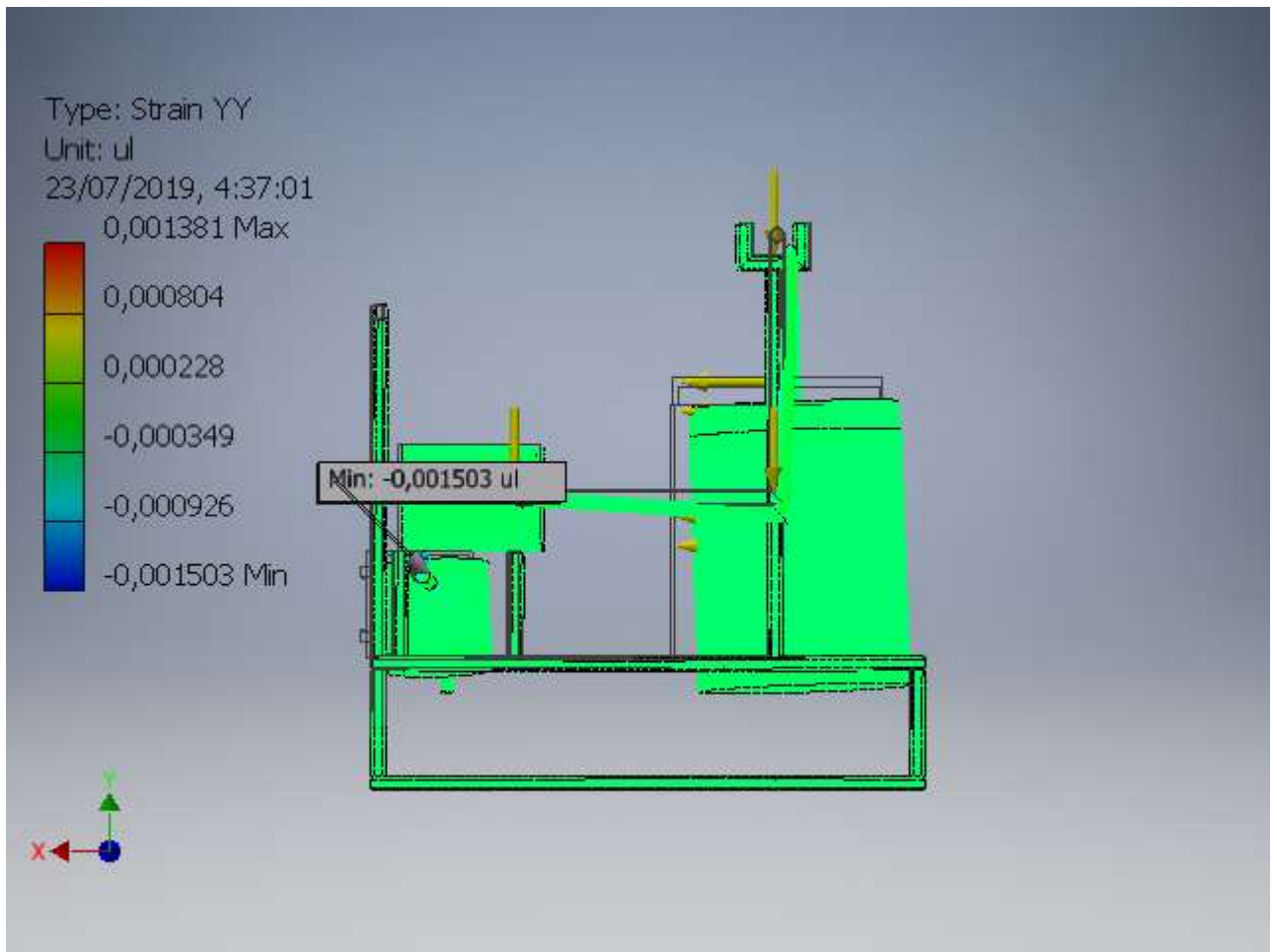

Strain YZ

Type: Strain YZ

Unit: ul

23/07/2019, 4:37:03

0,00142 Max

0,000938

0,000456

-0,000027

-0,000509

-0,000991 Min

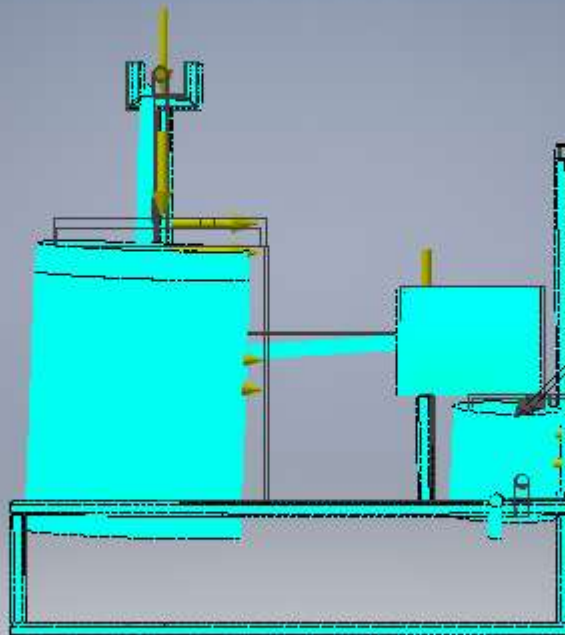

Min: -0,000991 ul

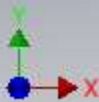

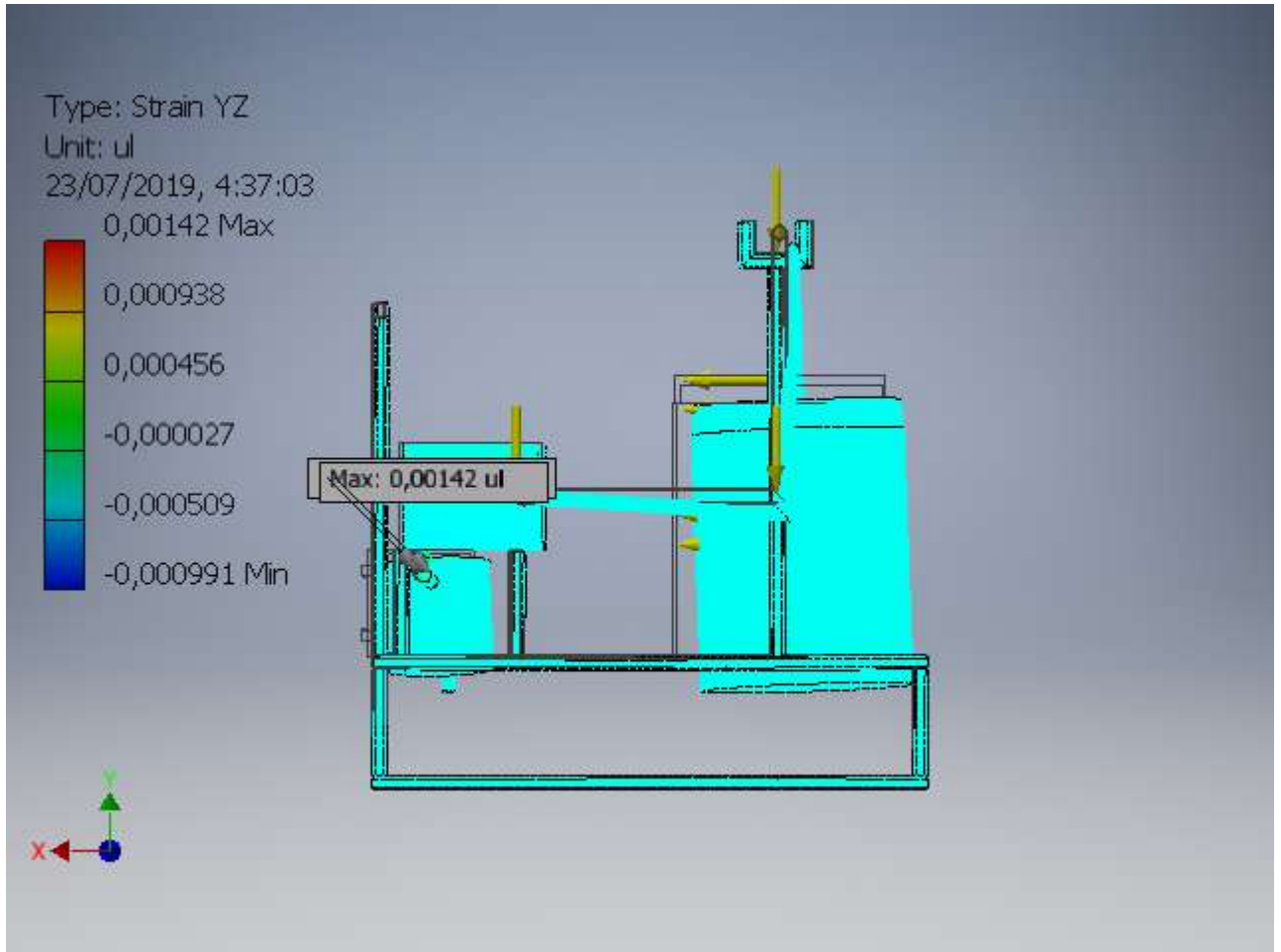

Strain ZZ

Type: Strain ZZ

Unit: ul

23/07/2019, 4:37:05

0,001347 Max

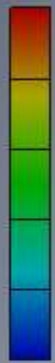

0,00069

0,000033

-0,000624

-0,00128

-0,001937 Min

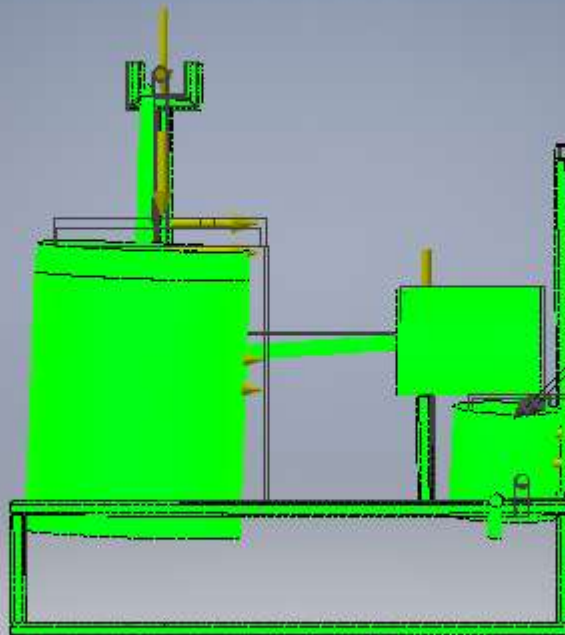

Max: 0,001347 ul

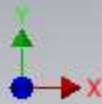

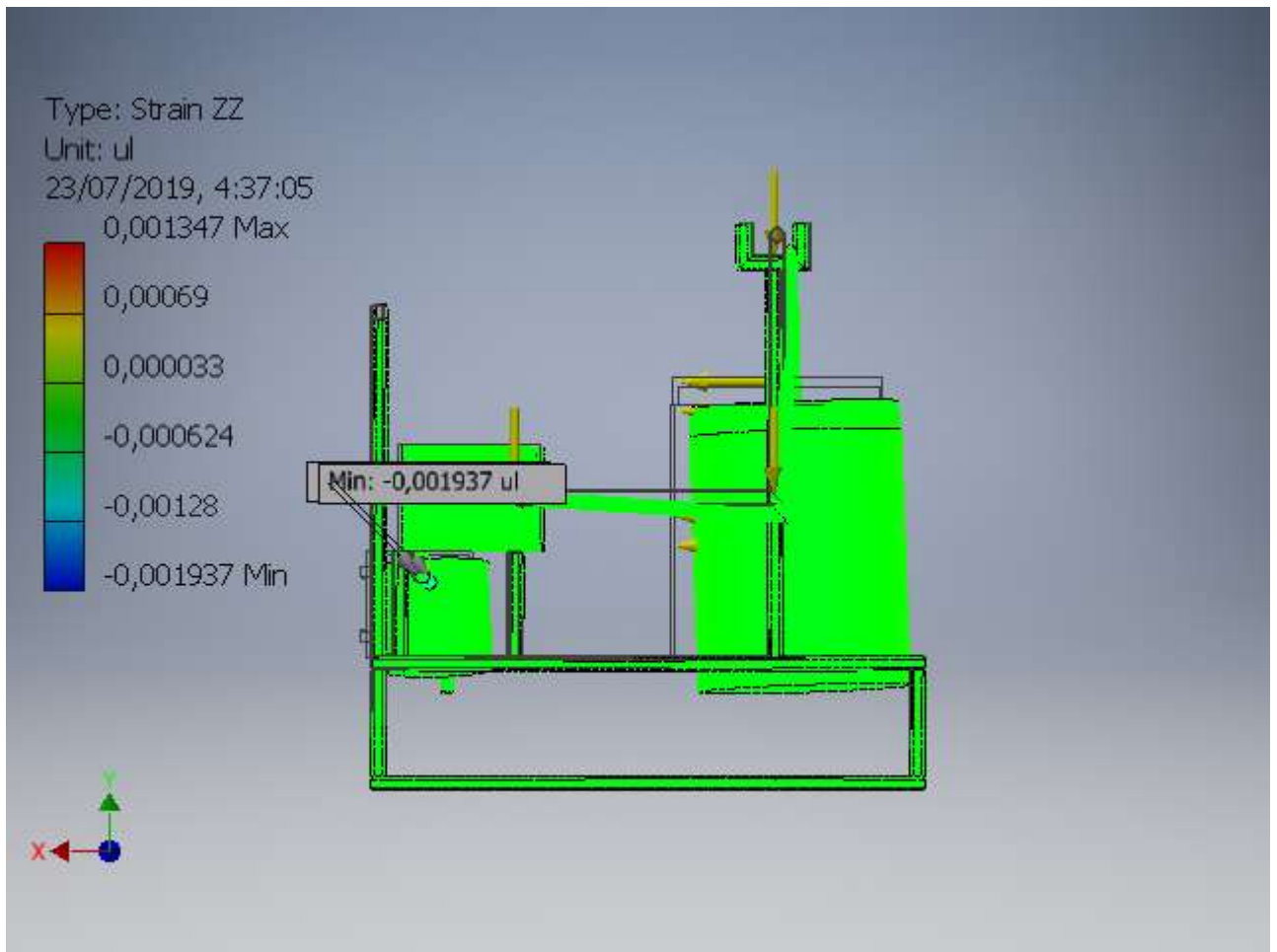

Contact Pressure

Type: Contact Pressure

Unit: MPa

23/07/2019, 4:37:08

476,9 Max

381,5

286,1

190,8

95,4

0 Min

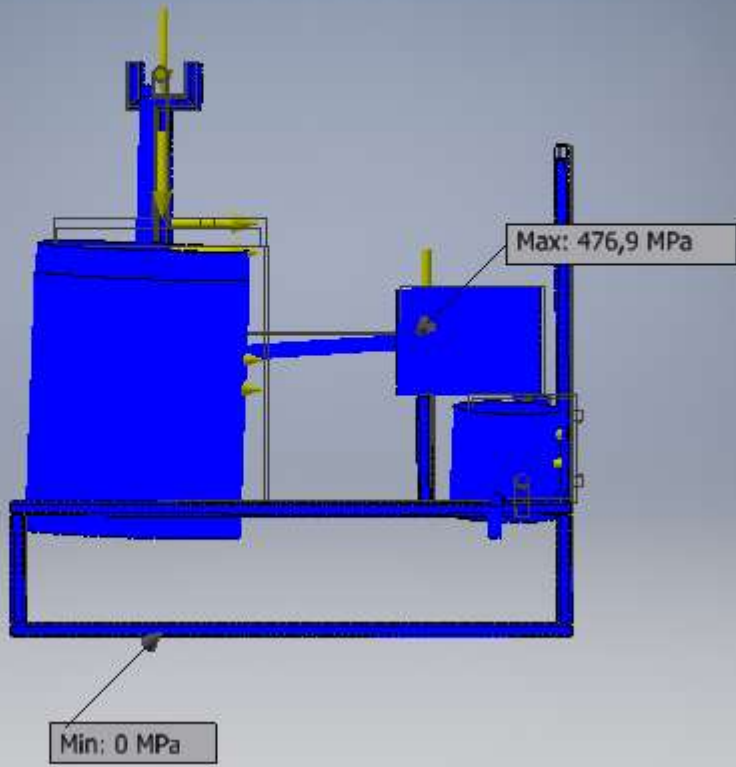

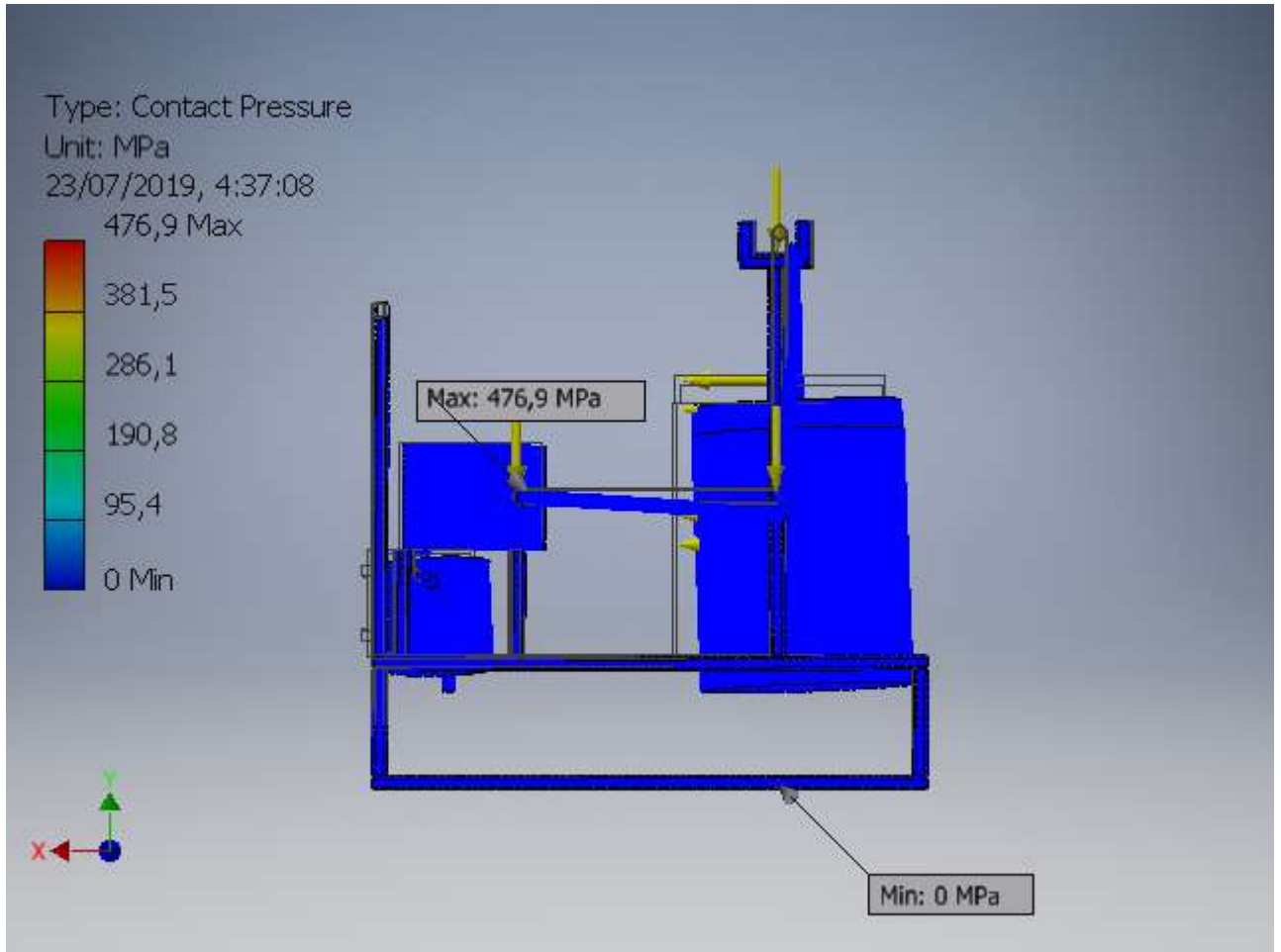

Contact Pressure X

Type: Contact Pressure X

Unit: MPa

23/07/2019, 4:37:09

314,3 Max

186,1

58

-70,2

-198,3

-326,4 Min

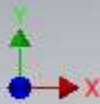
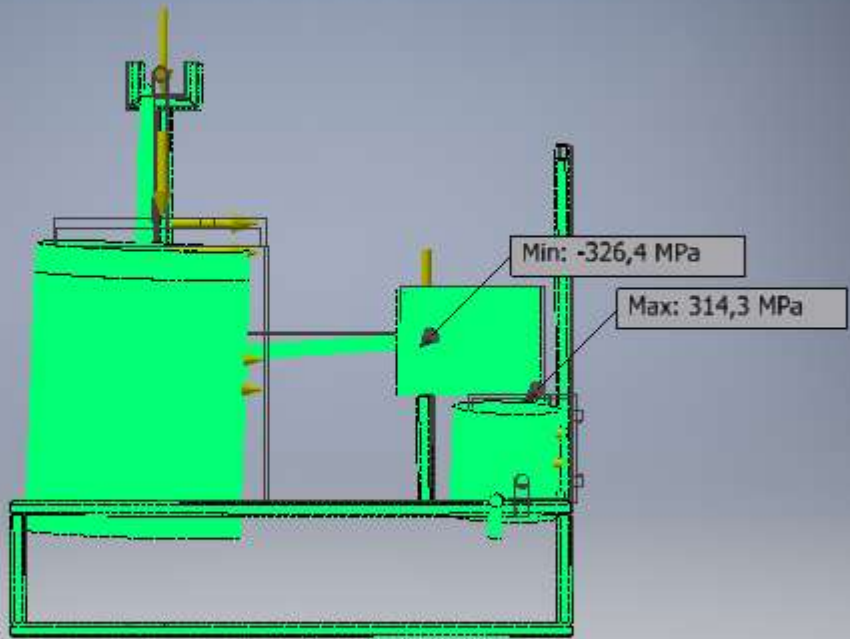

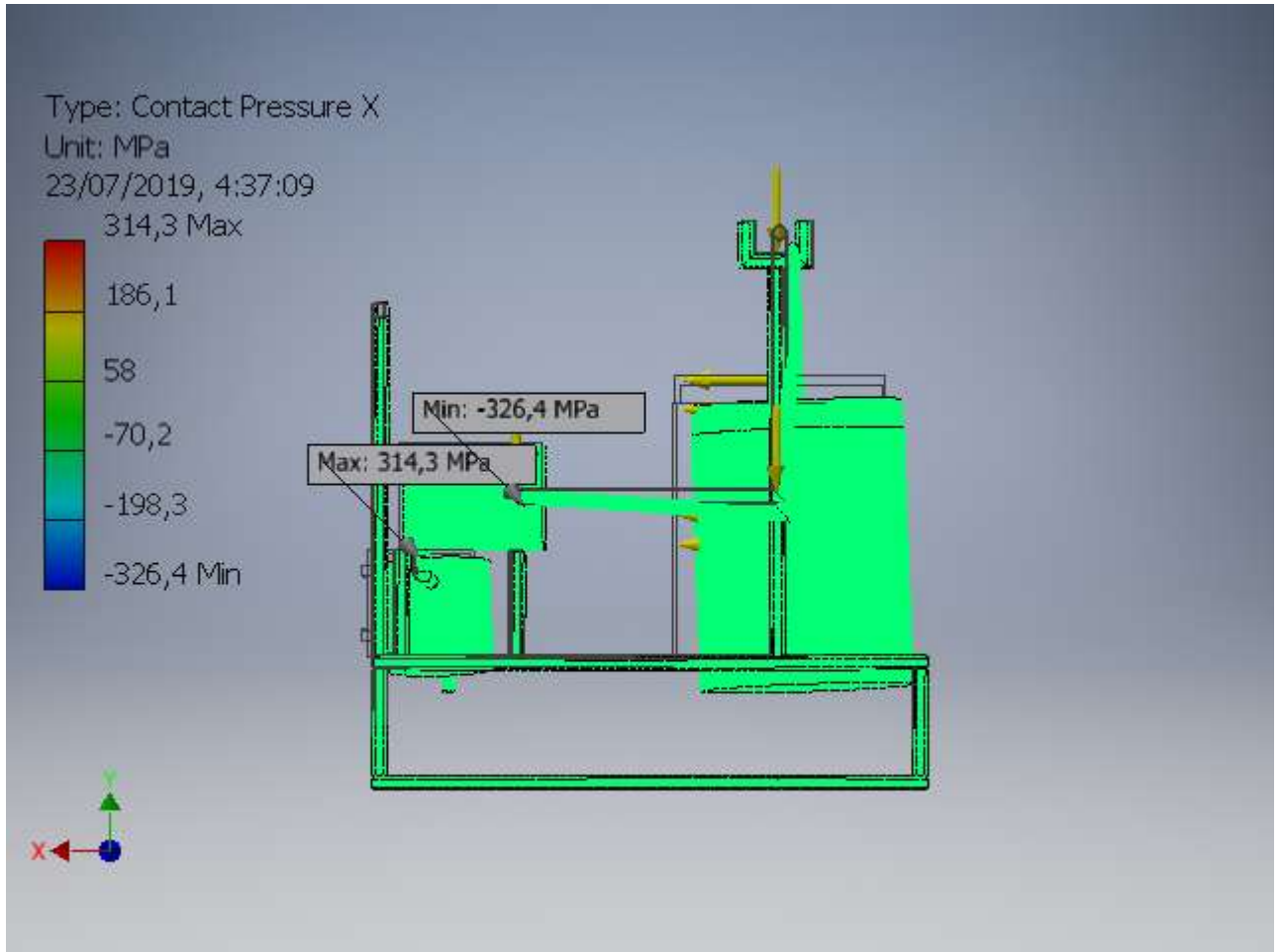

Contact Pressure Y

Type: Contact Pressure Y

Unit: MPa

23/07/2019, 4:37:12

359,3 Max

228,3

97,4

-33,6

-164,6

-295,6 Min

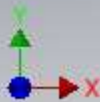
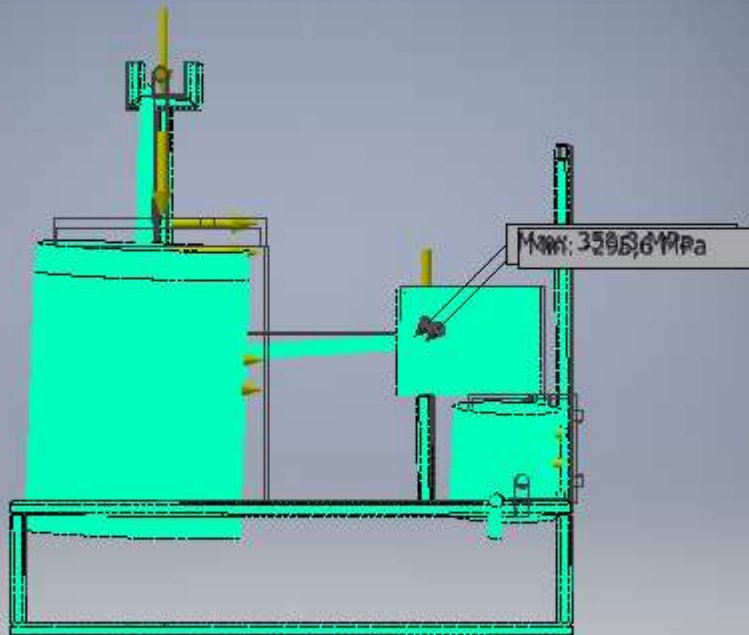

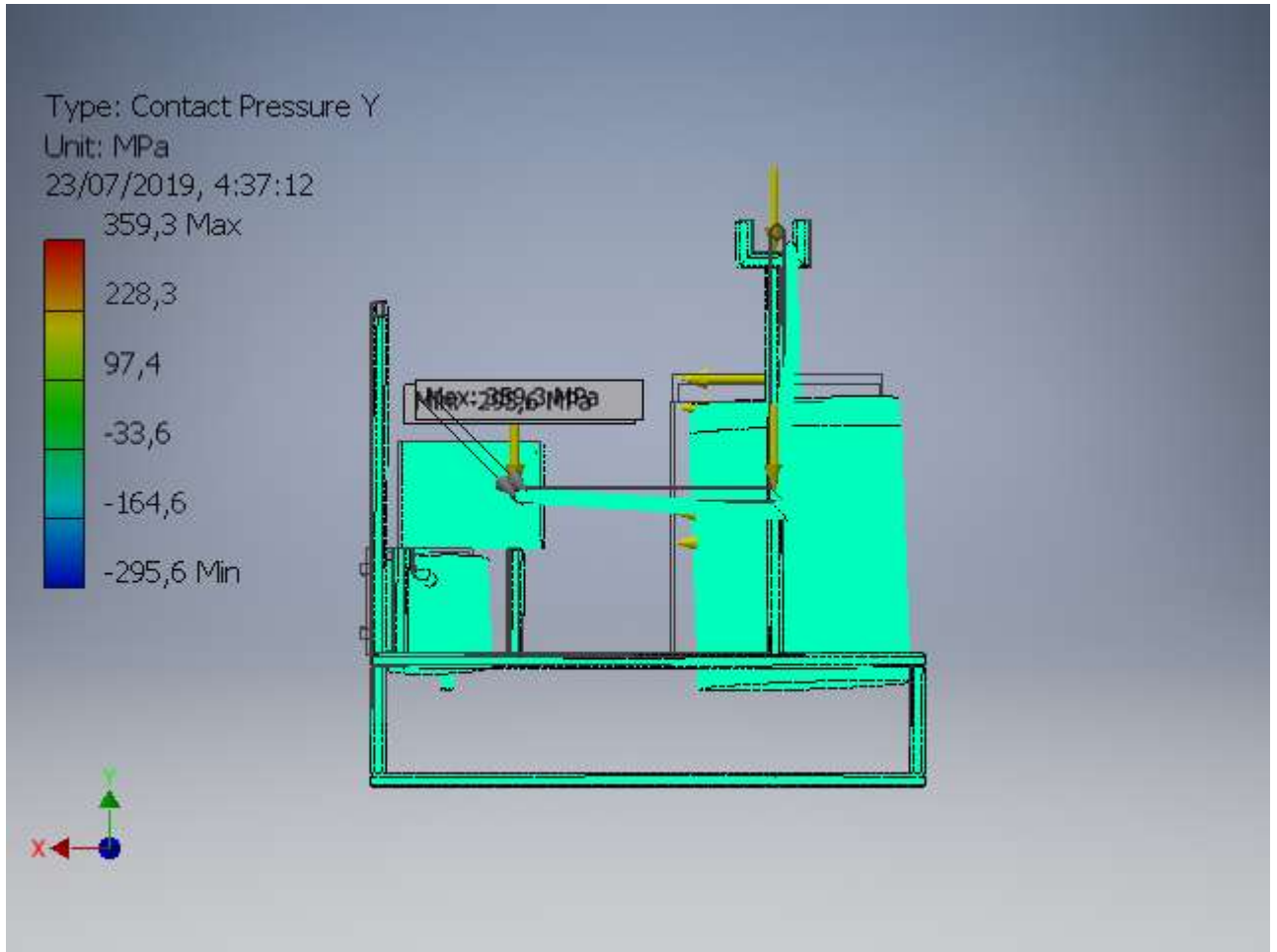

Contact Pressure Z

Type: Contact Pressure Z

Unit: MPa

23/07/2019, 4:37:14

273,5 Max

151,5

29,5

-92,5

-214,5

-336,6 Min

Max: 273,5 MPa

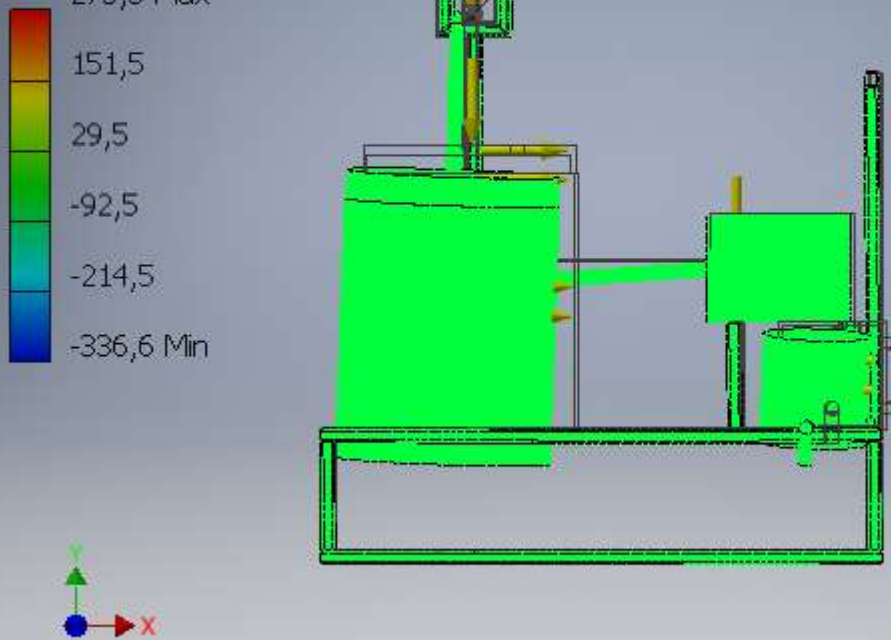

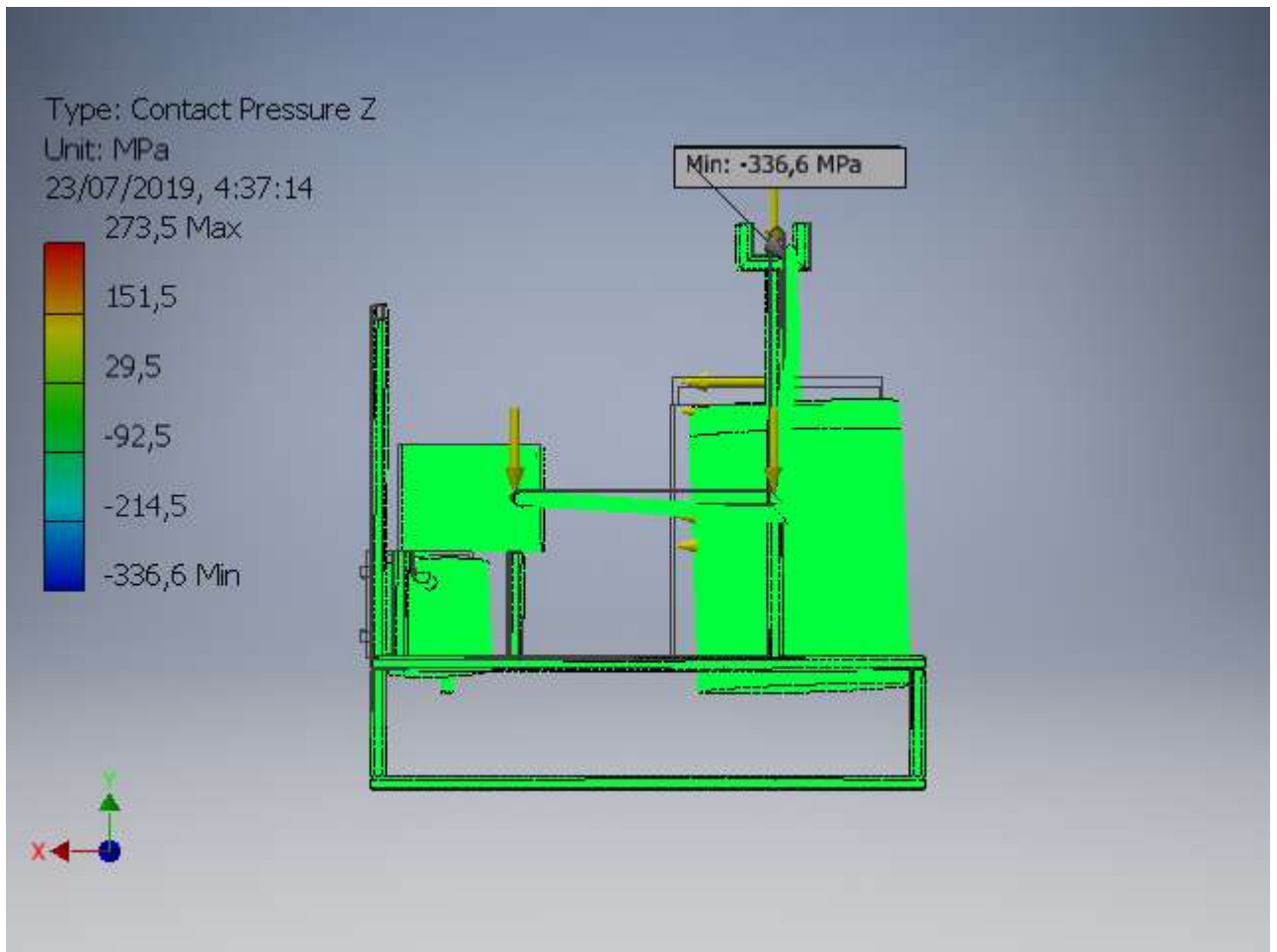

D:\Data\cahyo\im\tes alat pirolisis.iam