







**KETERANGAN :**

- DVRM     DIGITAL VIDEO RECORDER + MULTIPLEXER
-      DOME CAMERA COLOUR PANTILD (PTZ)
-      DOME CAMERA COLOUR FIXED
-      CAMERA COLOUR FIXED
-      C/W HOUSING INDOOR TYPE
-      CAMERA COLOUR FIXED
-      C/W HOUSING OUTDOOR TYPE
-      SOCKET OUTLET 200 W



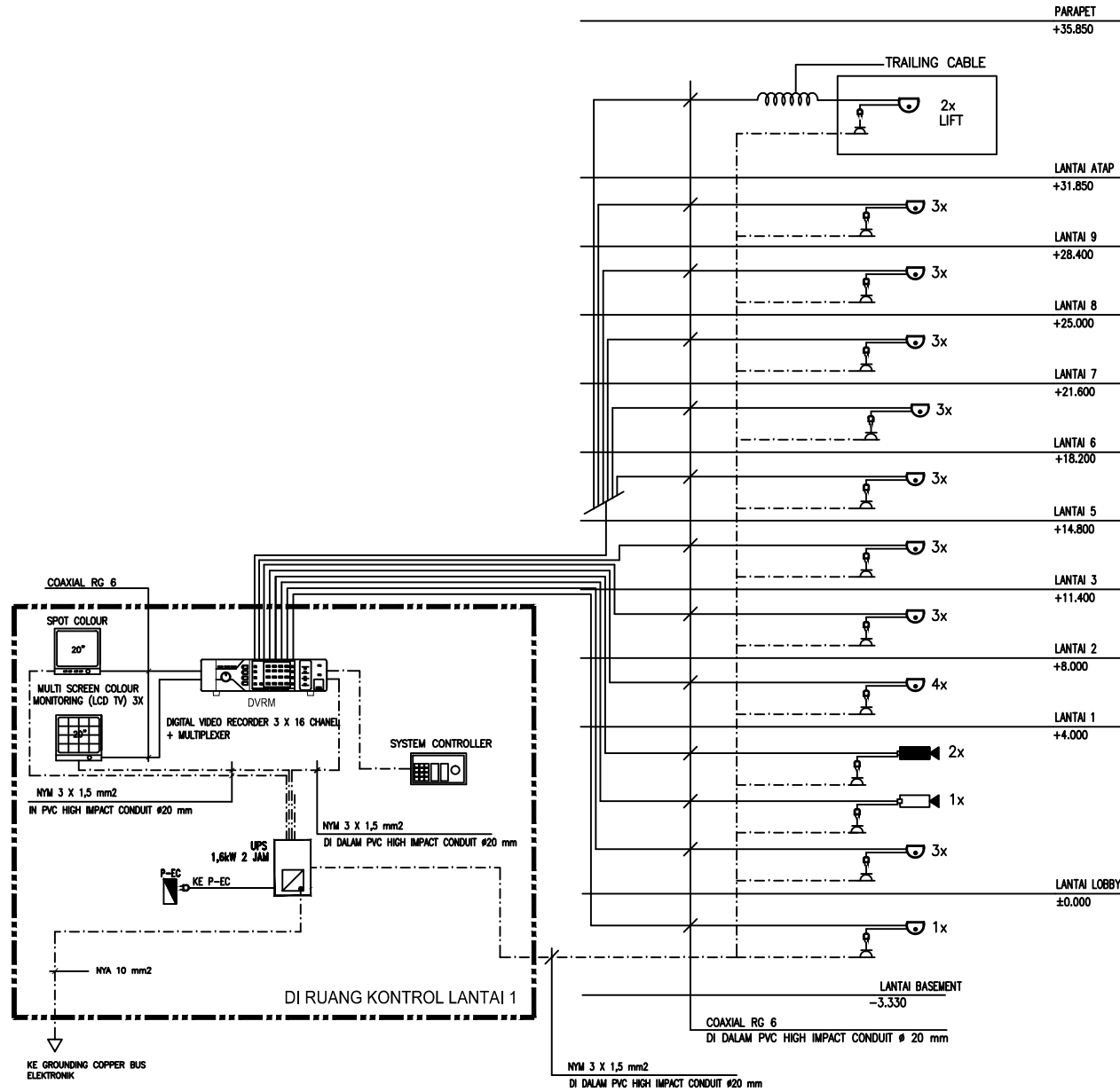
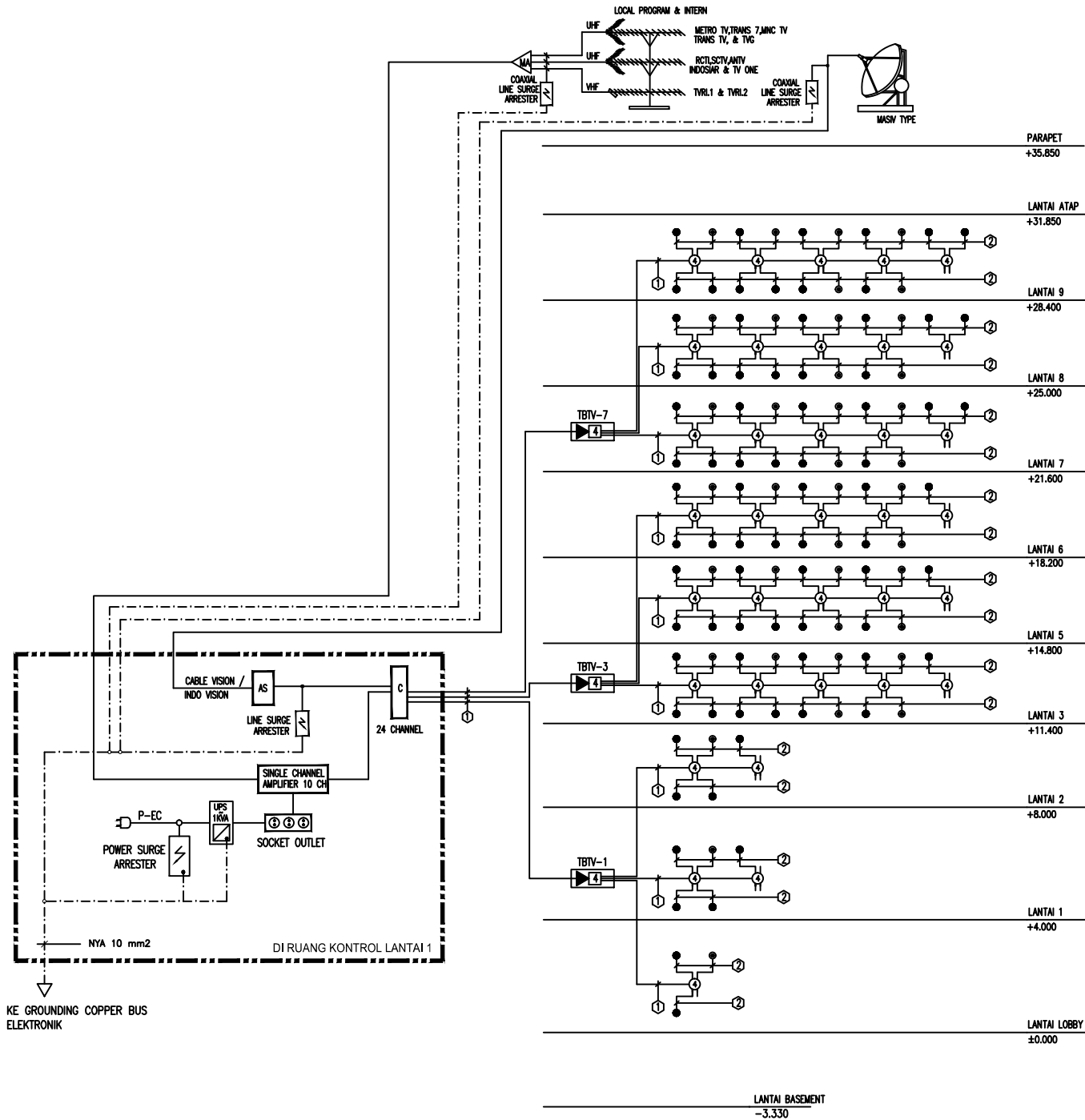

- KETERANGAN :**
- = COMBINER
  - = ACTIVE SPLITTER
  - = MASTHEAD AMPLIFIER
  - = BOOSTER
  - = COUPLER 4 WAY
  - = COUPLER 2 WAY
  - = SPLITTER 2 WAY
  - = SPLITTER 4 WAY
  - TV = TV OUTLET ( METAL )
  - = COAXIAL CABLE RG-11 75 Ohm
  - = COAXIAL CABLE RG-6 75 Ohm
  - TBTV = TERMINAL BOX MATV

KE GROUNDING COPPER BUS ELEKTRONIK

LANTAI BASEMENT  
-3.330

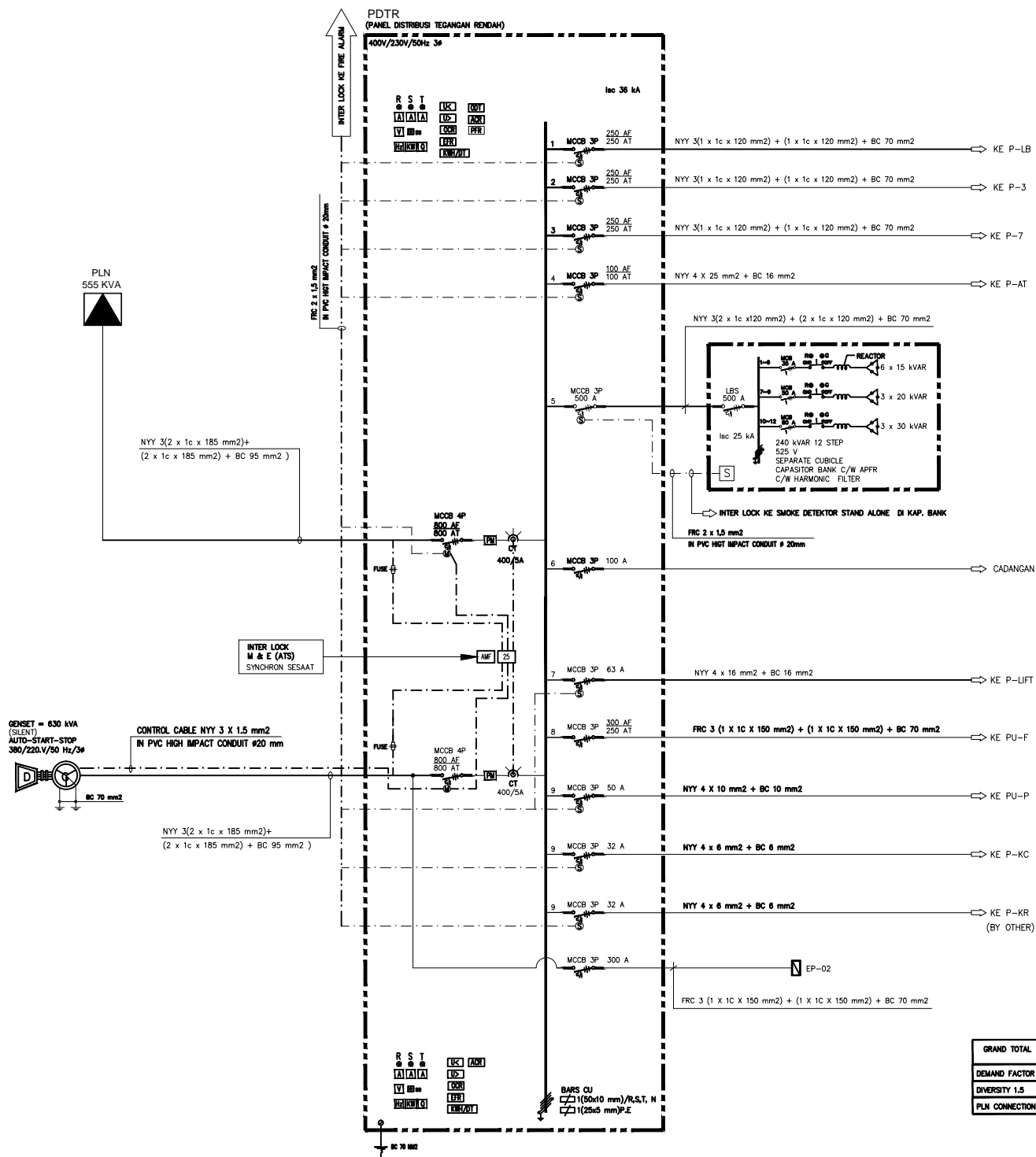

	BEBAN (W)	
	NORMAL	EMERGENCY
1	118311	118311
2	133674	133674
3	139620	139620
4	44300	44300
5		
6		
7	16000	16000
8	94046	94046
9	19097	19097
10	15000	15000
11	-	-
12	-	-
GRAND TOTAL	486002 W 607503 VA	486002 W 607503 VA
DEMAND FACTOR 0.8	486002 VA	486002 VA
DIVERSITY 1.5	324002	324002
PLN CONNECTION	345 KVA	

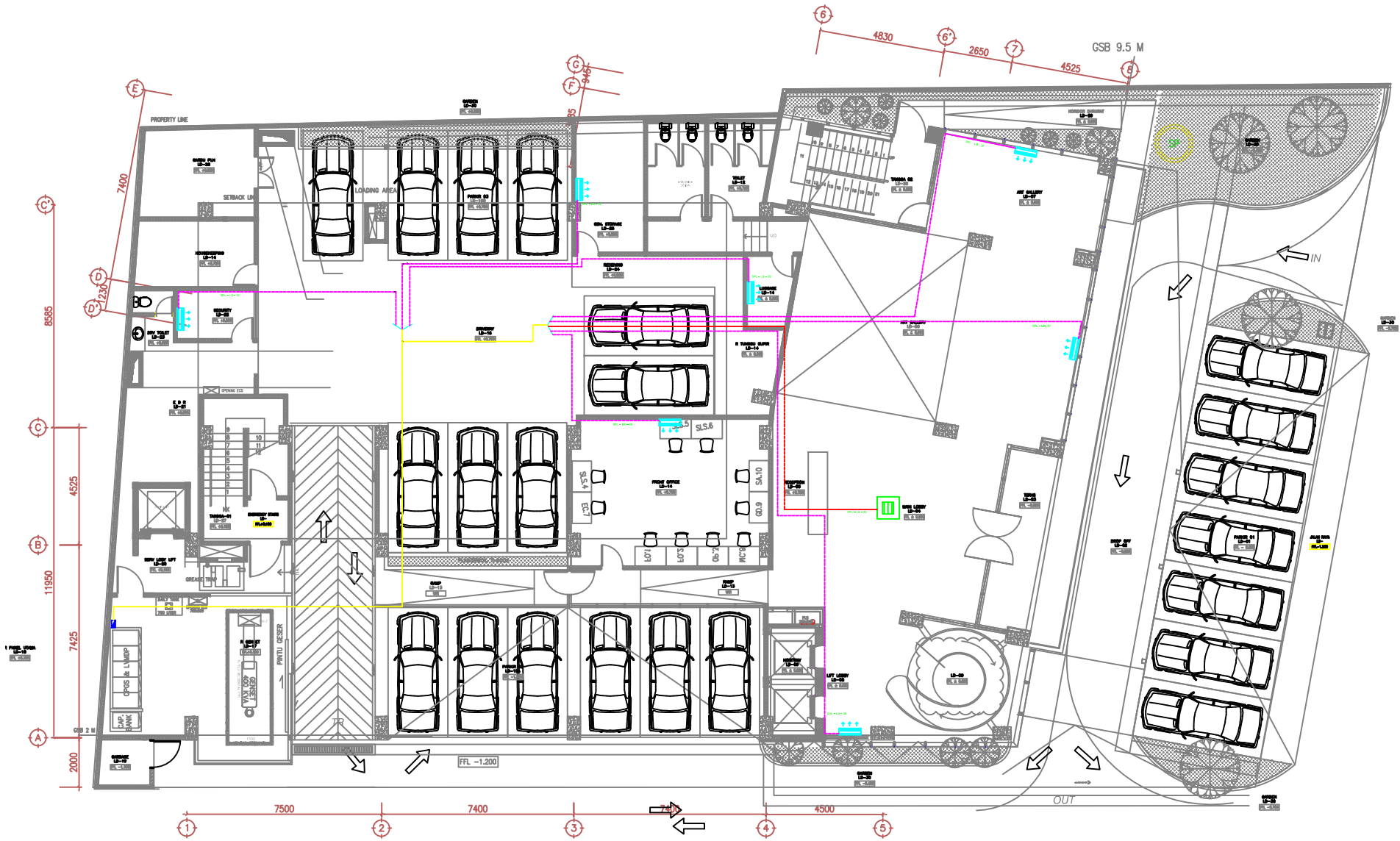

1  
A1-001

**DENAH LT LOBBY**  
SKALA 1 : 100



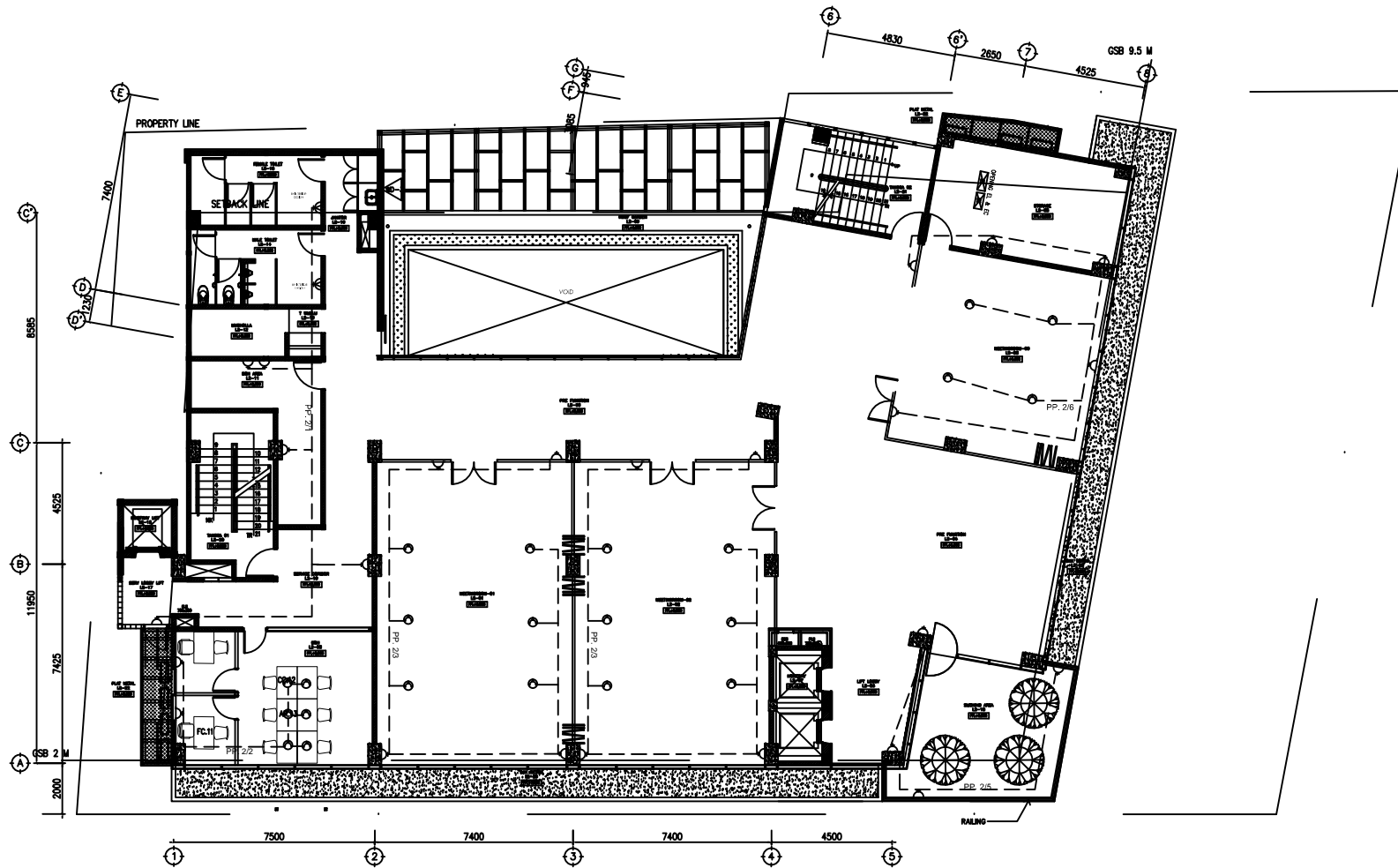

1
A1-001
**DENAH LT. 2 LVL + 8.000**  
 SKALA 1 : 100

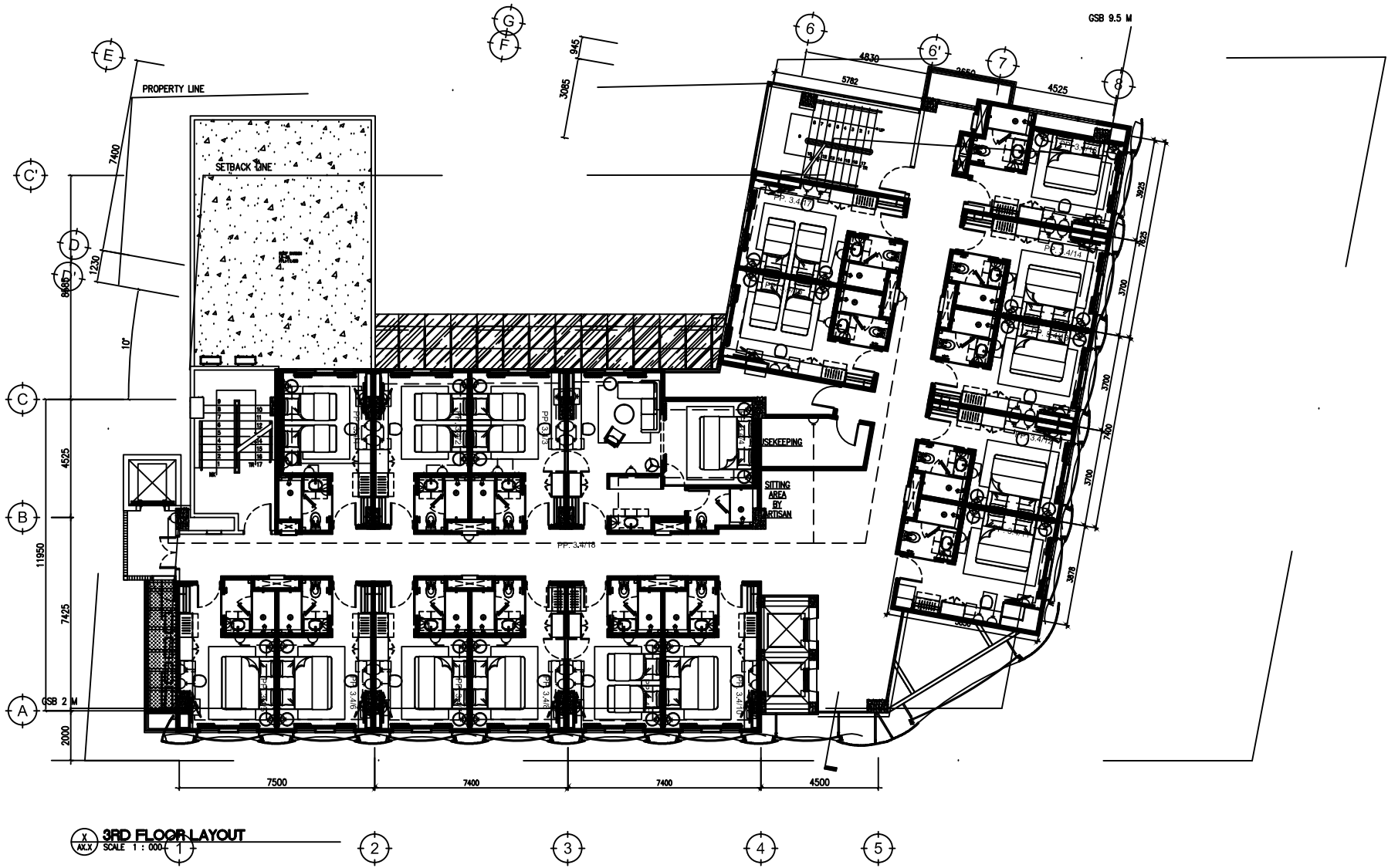

**3RD FLOOR LAYOUT**  
 SCALE: 1 : 1000

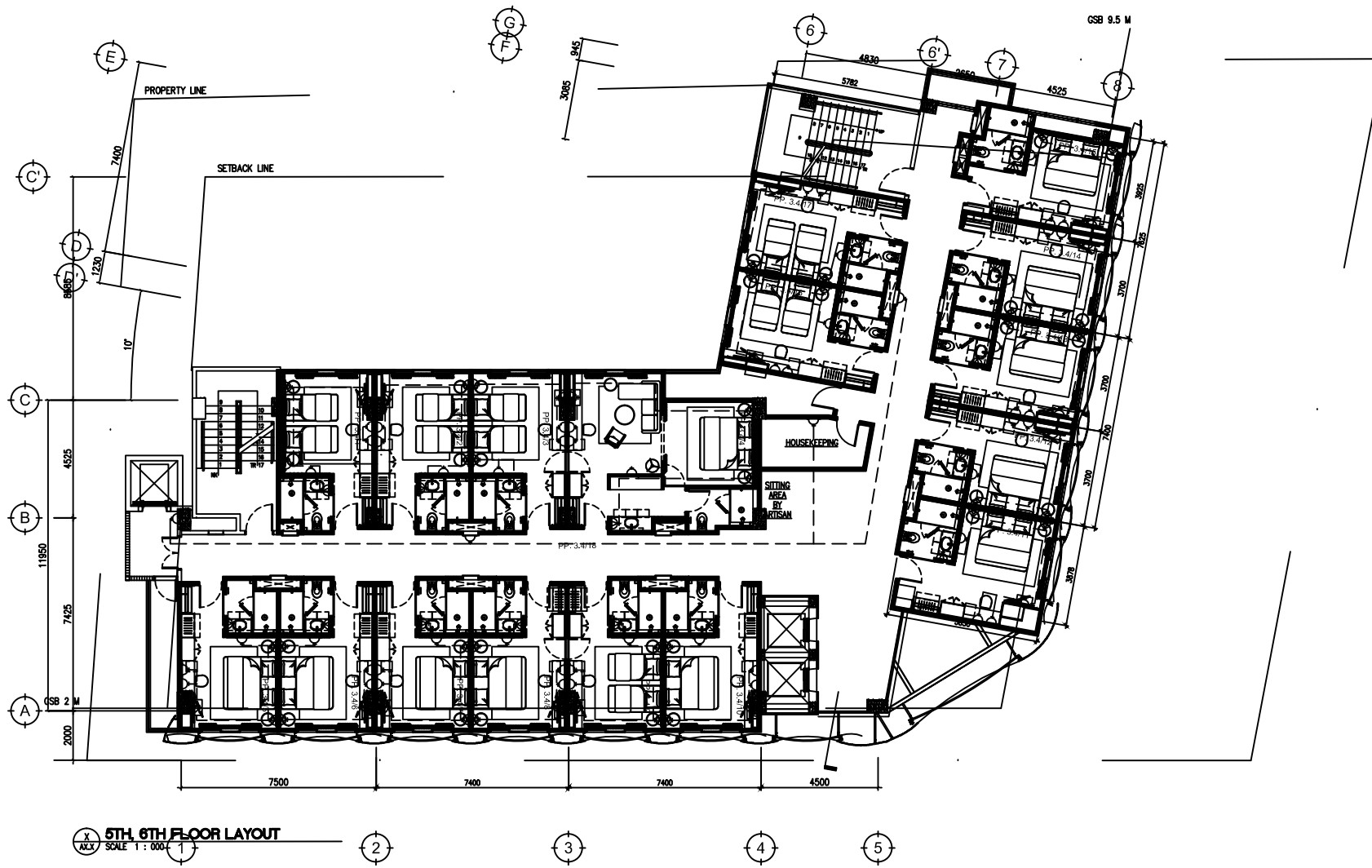





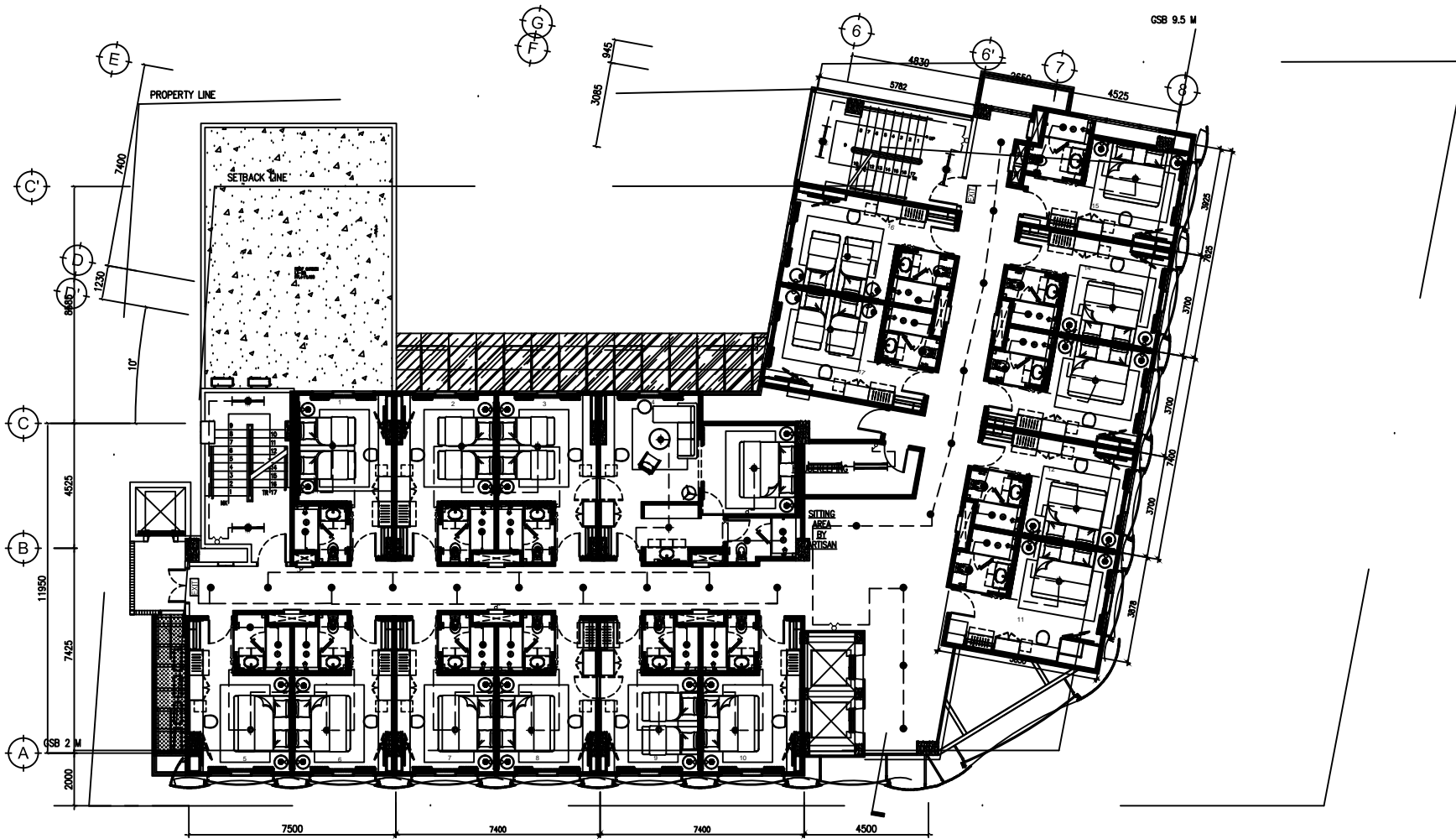

3RD FLOOR LAYOUT  
 SCALE 1 : 000





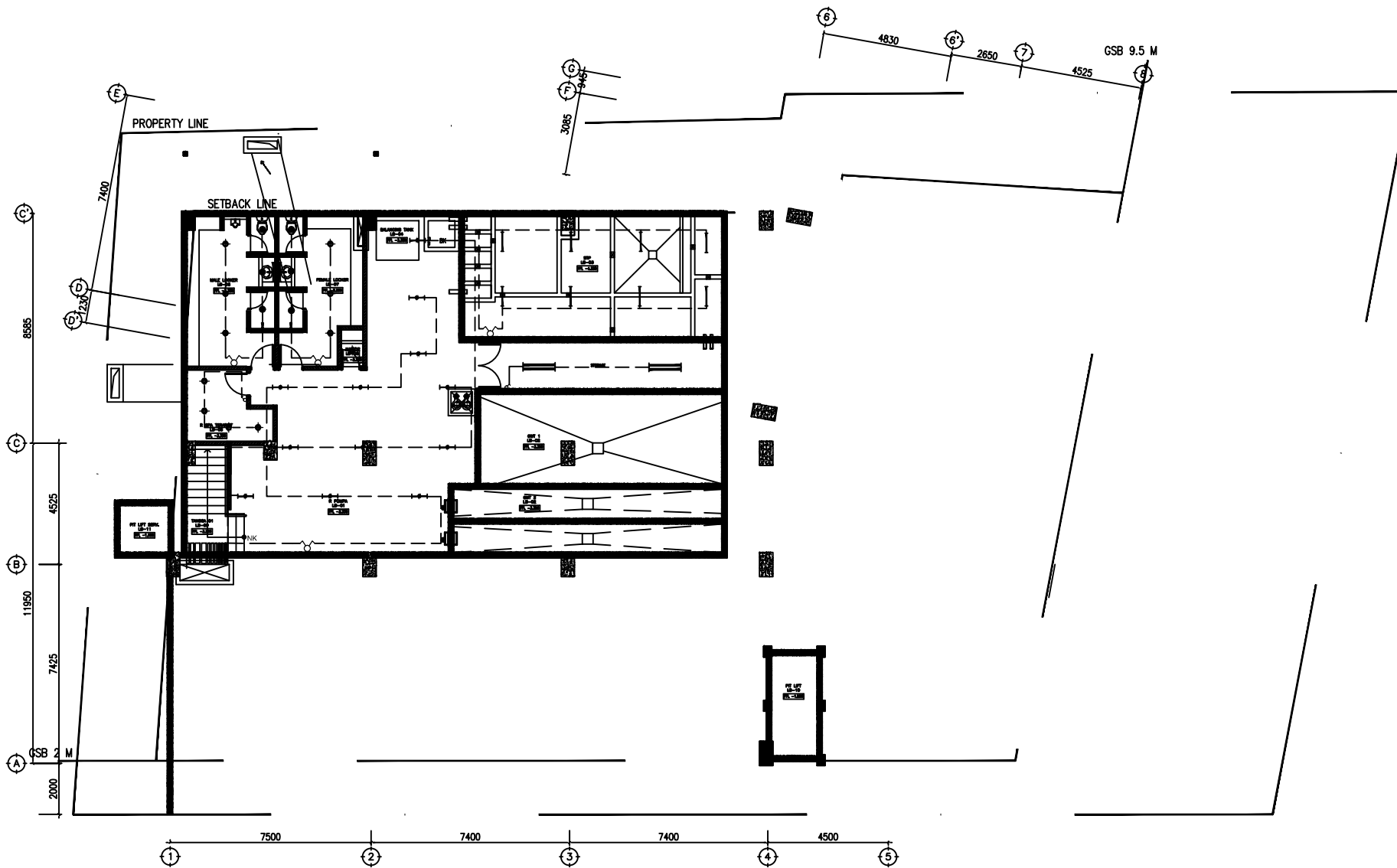

1  
A1-001

# DENAH BASEMENT

SKALA 1 : 100

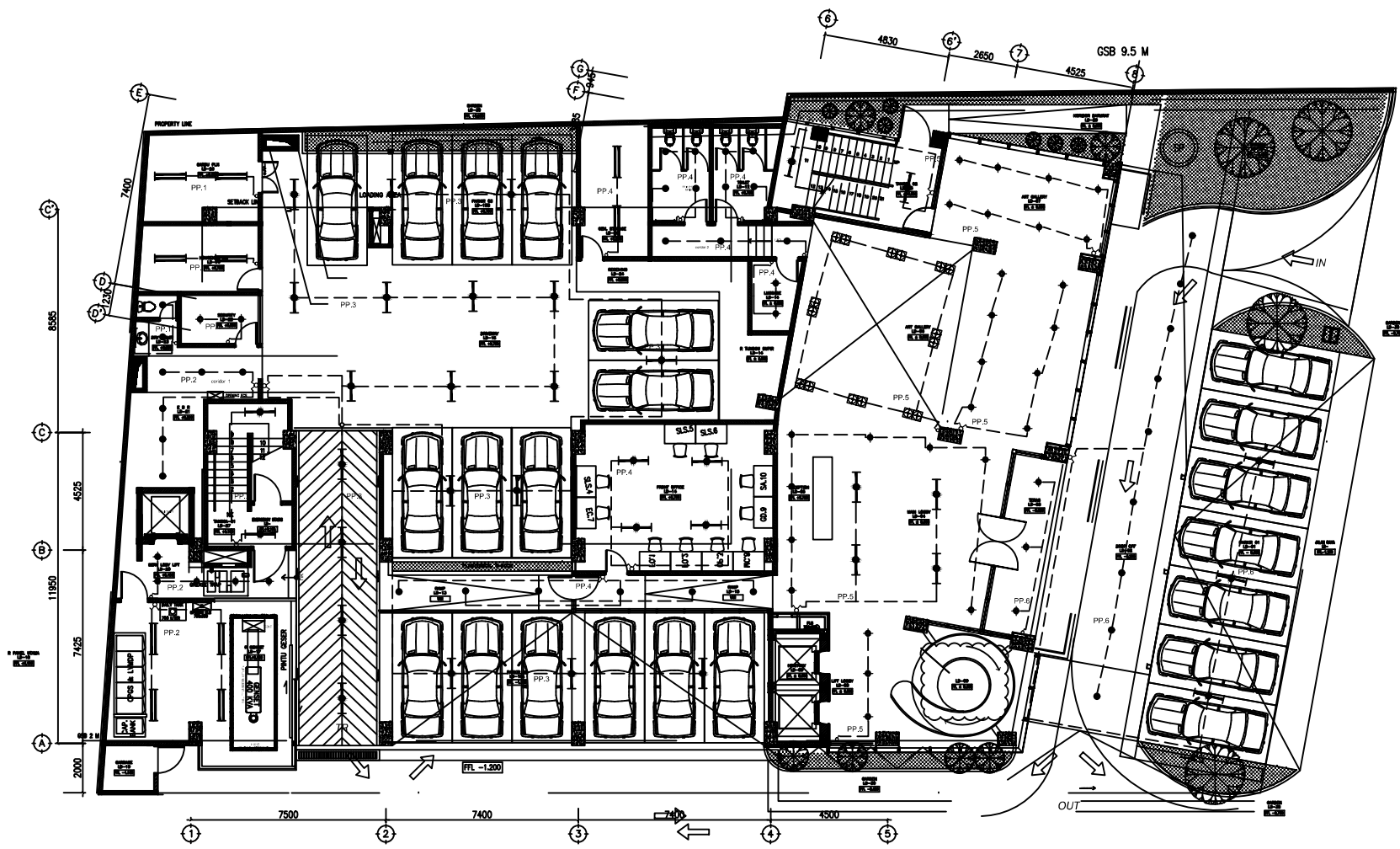

1  
A1-001

DENAH LT LOBBY  
SKALA 1 : 100



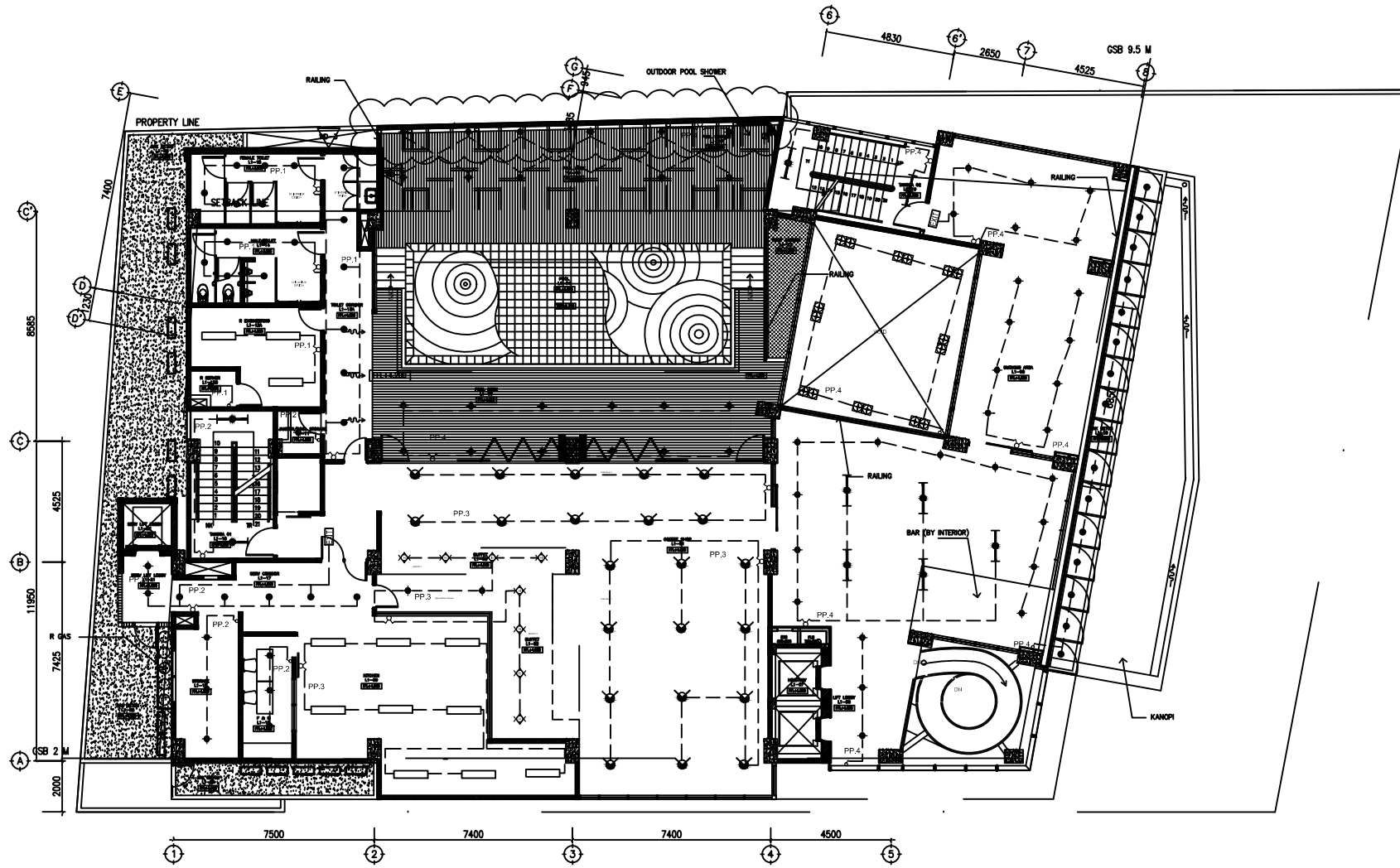

1
**DENAH LT 1**  
 A1-001 SKALA 1 : 100

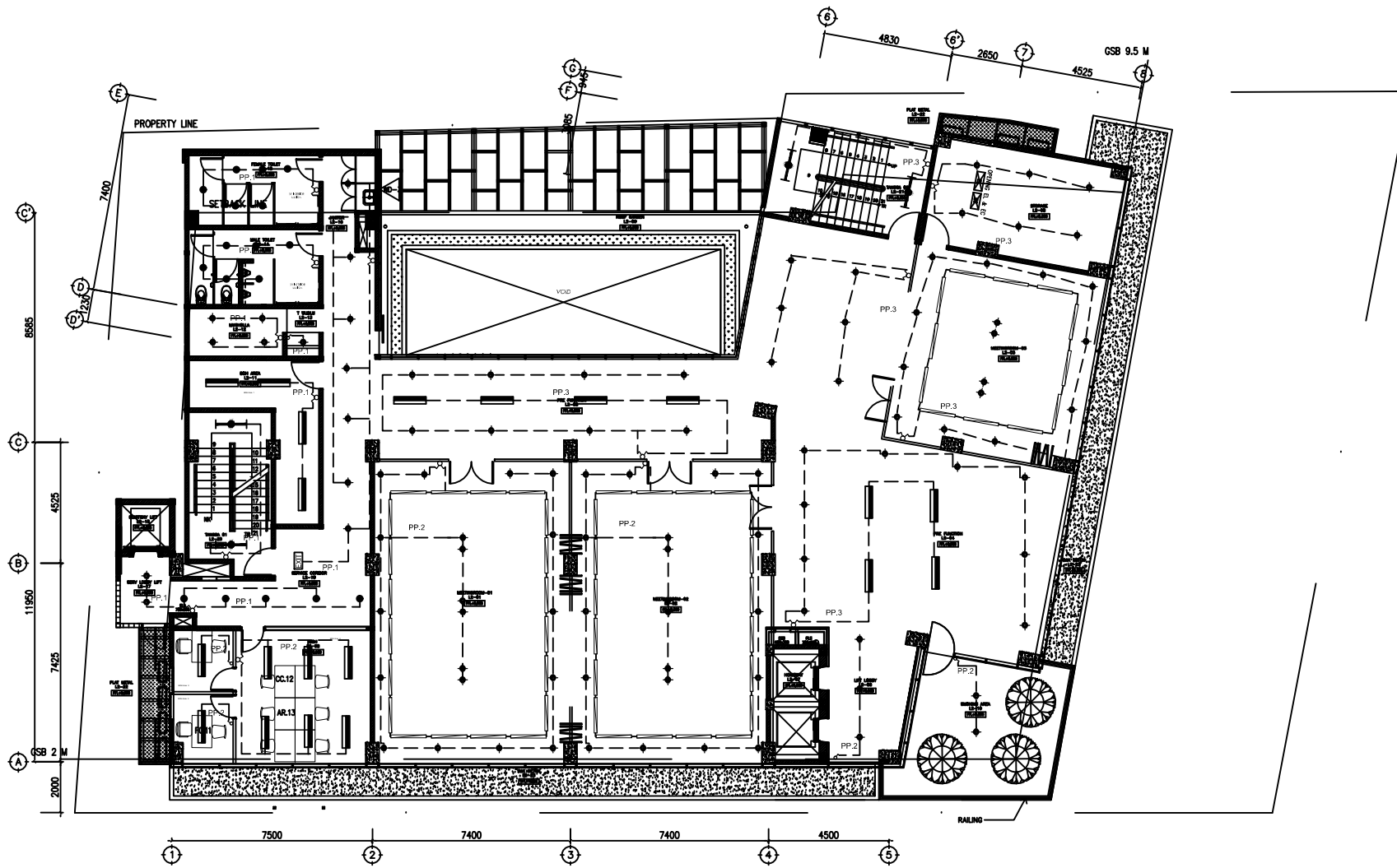

1  
A1-001

**DENAH LT. 2 LVL + 8.000**

SKALA 1 : 100

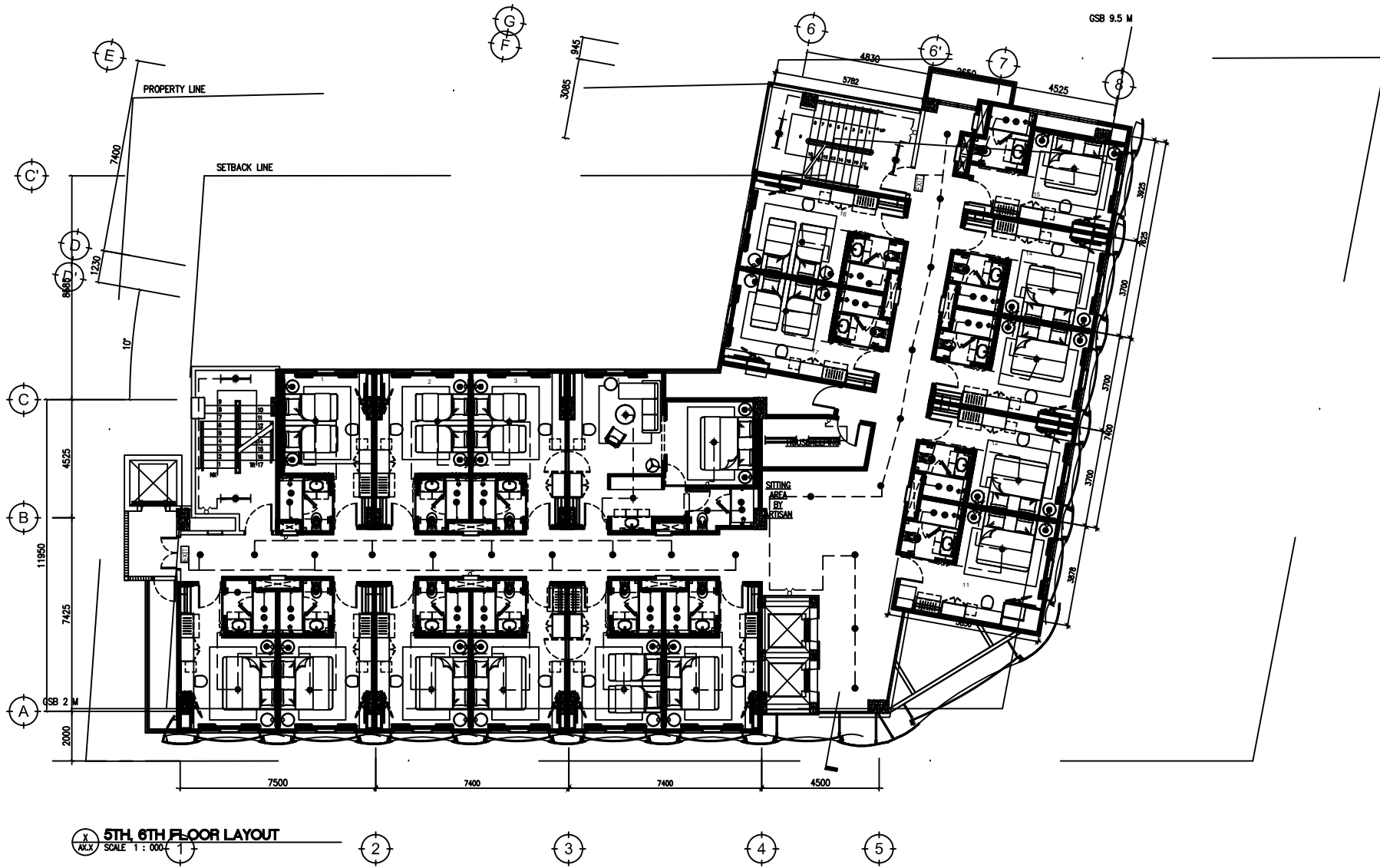

**5TH, 6TH FLOOR LAYOUT**  
 SCALE 1 : 000



