

A (1:6)

Ø10,00 -40,00 DEEP

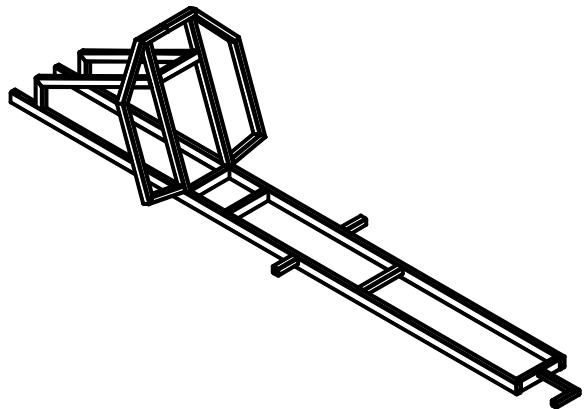

GTAW

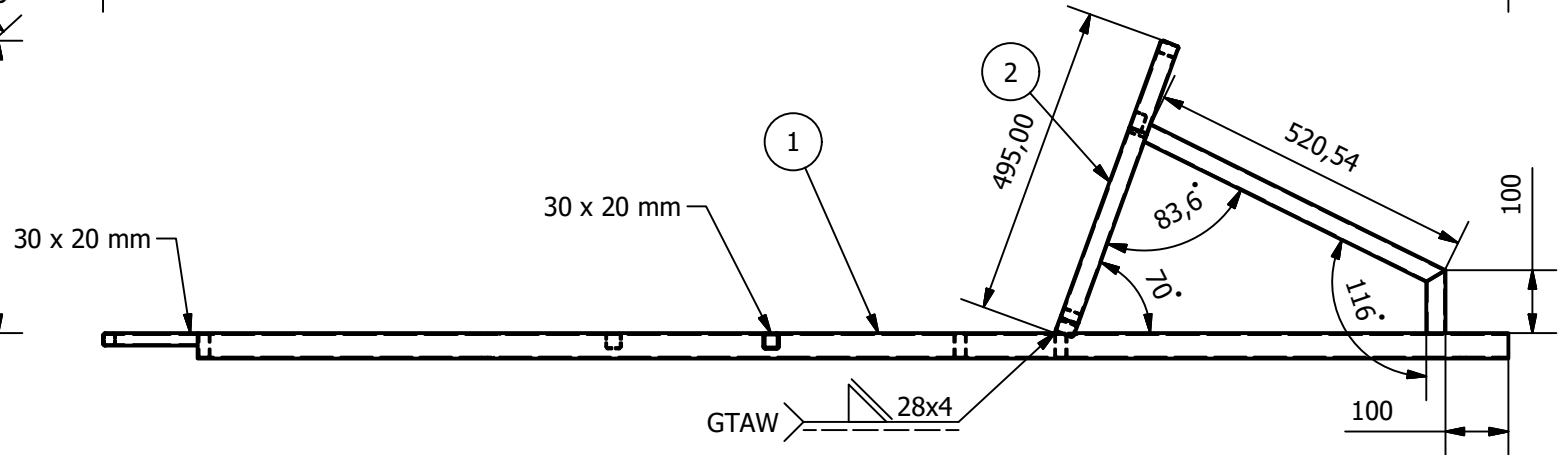
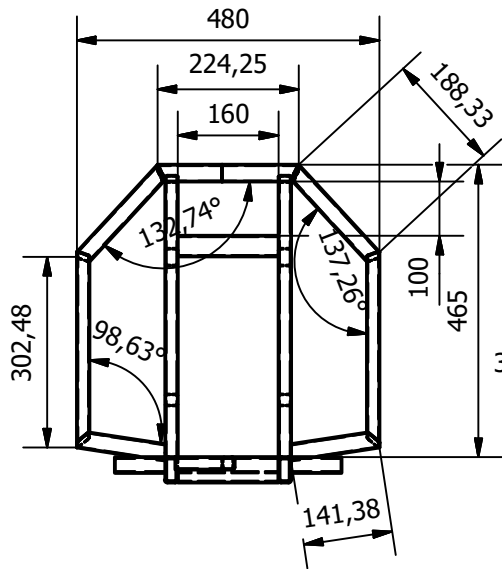
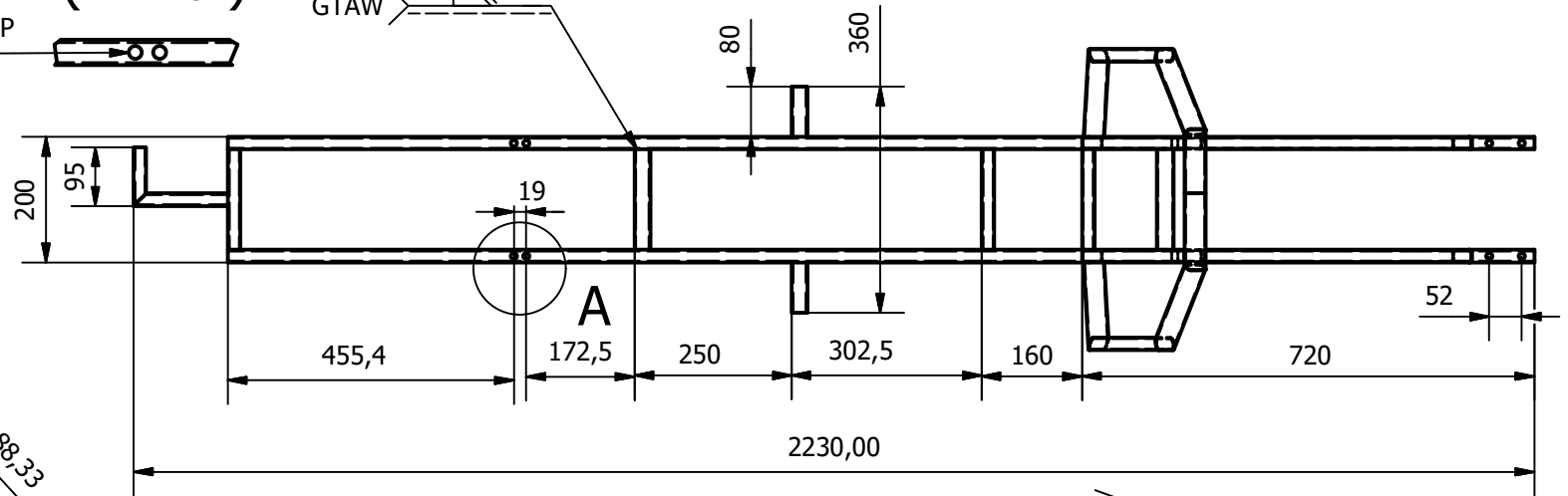

2	1	Roll Bar	Aluminium 6061	30 x 20 x 1,5 mm	Rectangular Hollow
1	1	Rangka Utama	Aluminium 6061	40 x 20 x 2 mm	Rectangular Hollow
NO	JML	NAMA	BAHAN	UKURAN	KETERANGAN
	Skala : 1 : 12		Digambar : Faiz Evan Saputra		Keterangan :
	Satuan : mm		No. Mhs : 20150130141		
	Tanggal : 03 Agustus 2018		Diperiksa : Ir Aris Widyo N, M.T.,Ph.D		
Teknik Mesin UMY			Rangka		NO : 1 A4

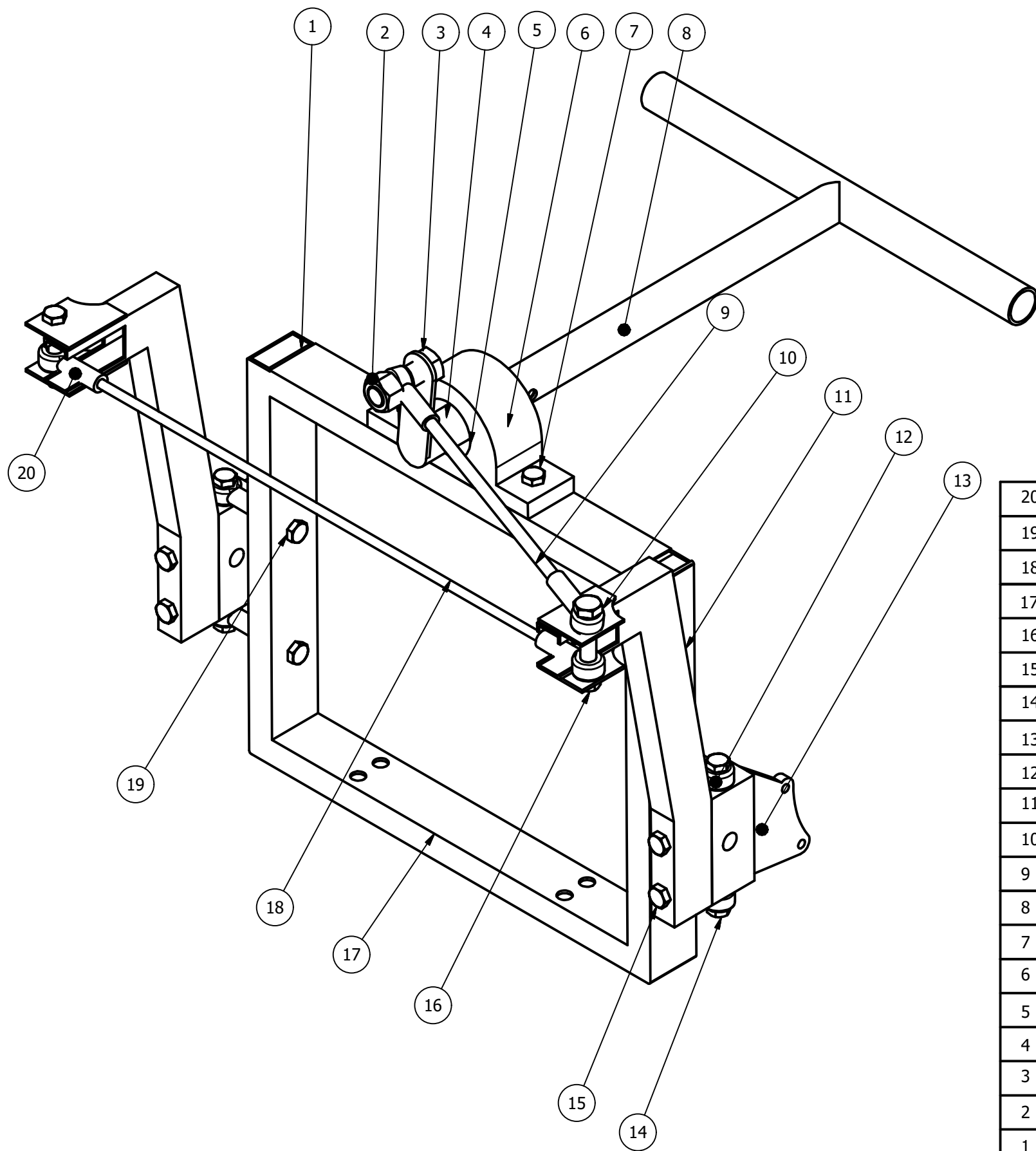

20	4	Ball Joint Linkage	Steel	6 mm	PHS 6 ASB
19	4	Baut Steering Shaft	Steel	M8x50	
18	1	Tie Rod Stabilizer	Steel		
17	1	Steering Shaft	Aluminium 6061		Rectangular Hollow w/Filler
16	2	Mur Linkage	Steel	M8	
15	4	Baut Steering Arm	Steel	M6x50	
14	4	Baut Bracket Wheel Front	Steel	M8x30	
13	2	Bracket Wheel Front	Aluminium 6061		
12	4	Ball Joint Bracket Roda	Steel	8 mm	PHS 8 ASB
11	2	Steering Arm	Steel		
10	2	Baut Linkage	Steel	M8x50	
9	1	Arm Connector	Aluminium 6061		Rectangular Hollow
8	1	Setang	Stainless Steel		
7	2	Baut Bracket Steering	Steel	M6x45	
6	1	Steering Bracket	Kayu Balsa		
5	1	Bearing	Steel		SKF Roller Bearing
4	1	Link Steering	Aluminium 6061		
3	1	Baut Link	Steel	M8x30	
2	1	Mur Link	Steel	M8	
1	3	Filler	Kayu Balsa		
NO	JML	NAMA	BAHAN	UKURAN	KETERANGAN



Skala : 1 : 8
 Satuan : mm
 Tanggal : 03 Agustus 2018

Digambar : Faiz Evan Saputra
 No. Mhs : 20150130141
 Diperiksa : Ir Aris Widyo N, M.T.,Ph.D

Keterangan :

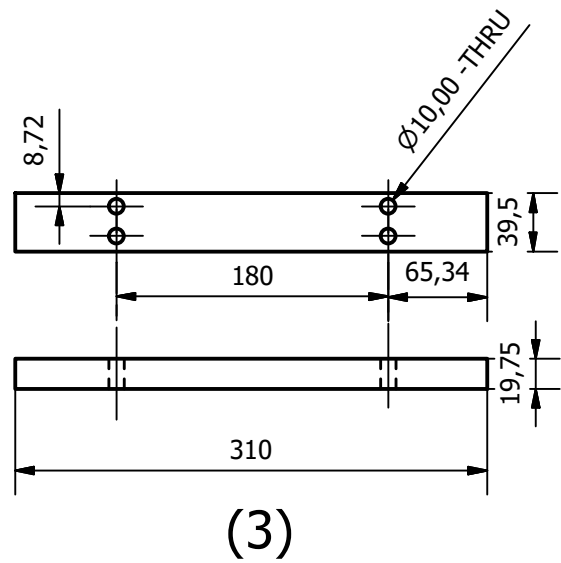
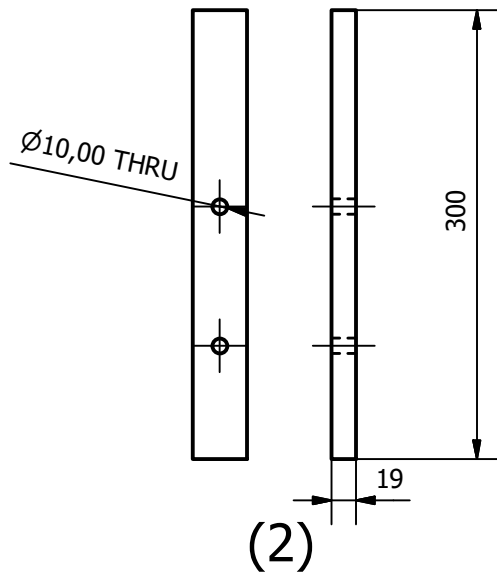

A (1:3)

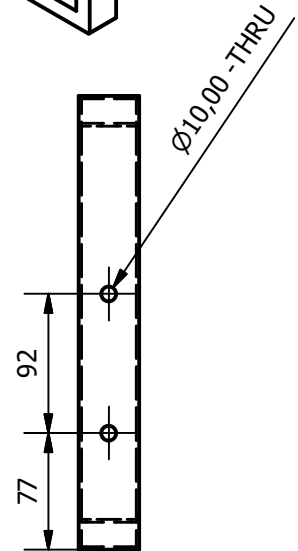
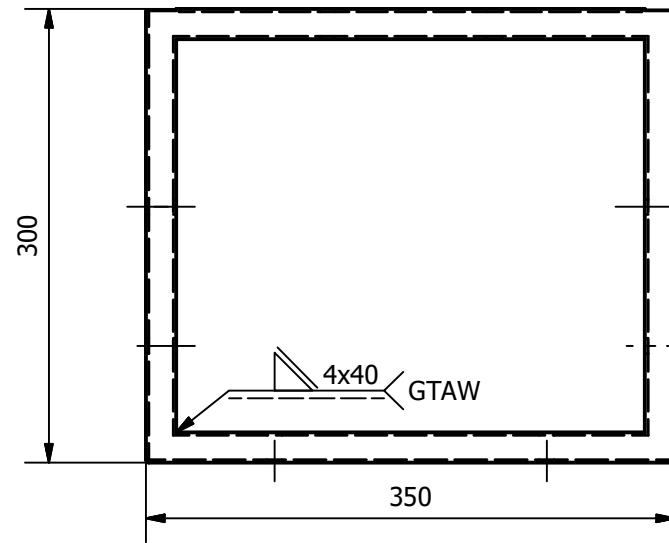
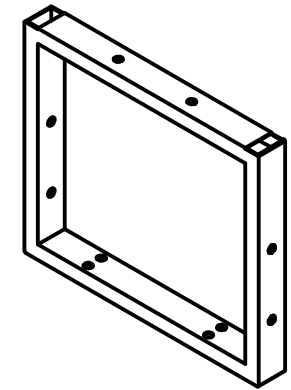
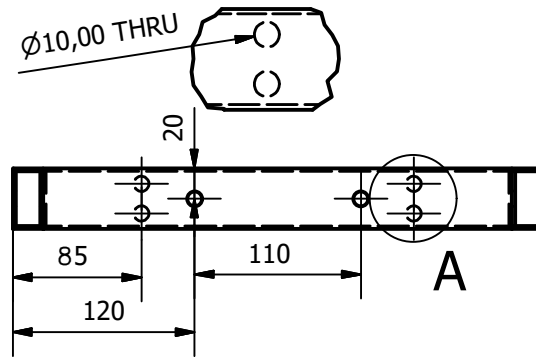

3	1	Filler 2	Kayu Balsa		
2	2	Filler 1	Kayu Balsa		
1	1	Steering Shaft	Aluminium 6061		
NO	JML	NAMA	BAHAN	UKURAN	KETERANGAN
	Skala : 1 : 8		Digambar : Faiz Evan Saputra		Keterangan :
	Satuan : mm		No. Mhs : 20150130141		
	Tanggal : 03 Agustus 2018		Diperiksa : Ir Aris Widyo N, M.T.,Ph.D		
Teknik Mesin UMY			Steering Shaft		NO : 3
					A4

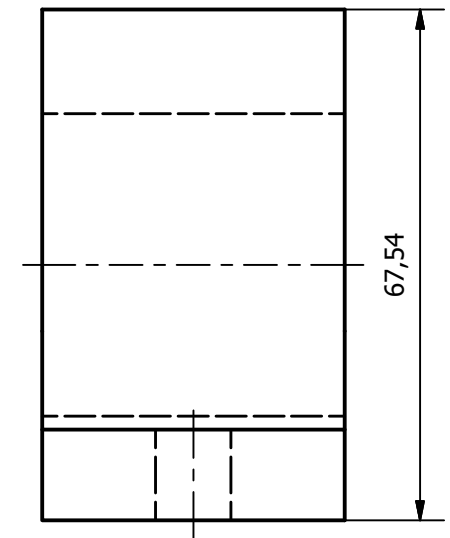
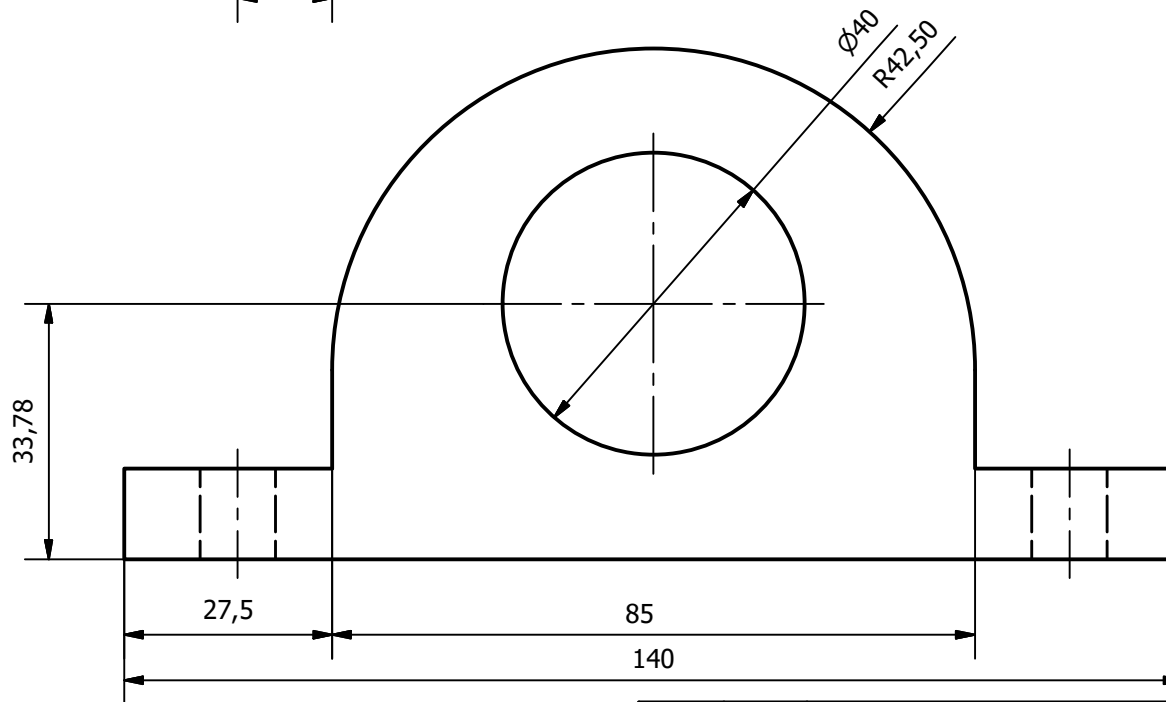
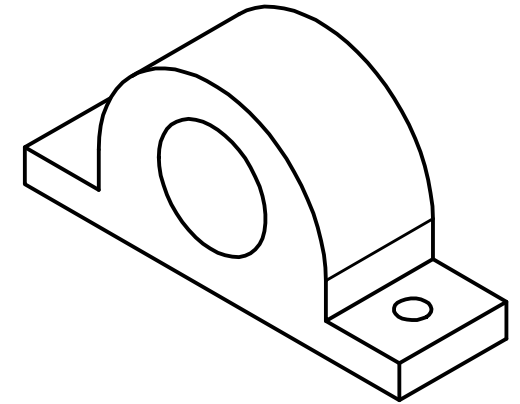
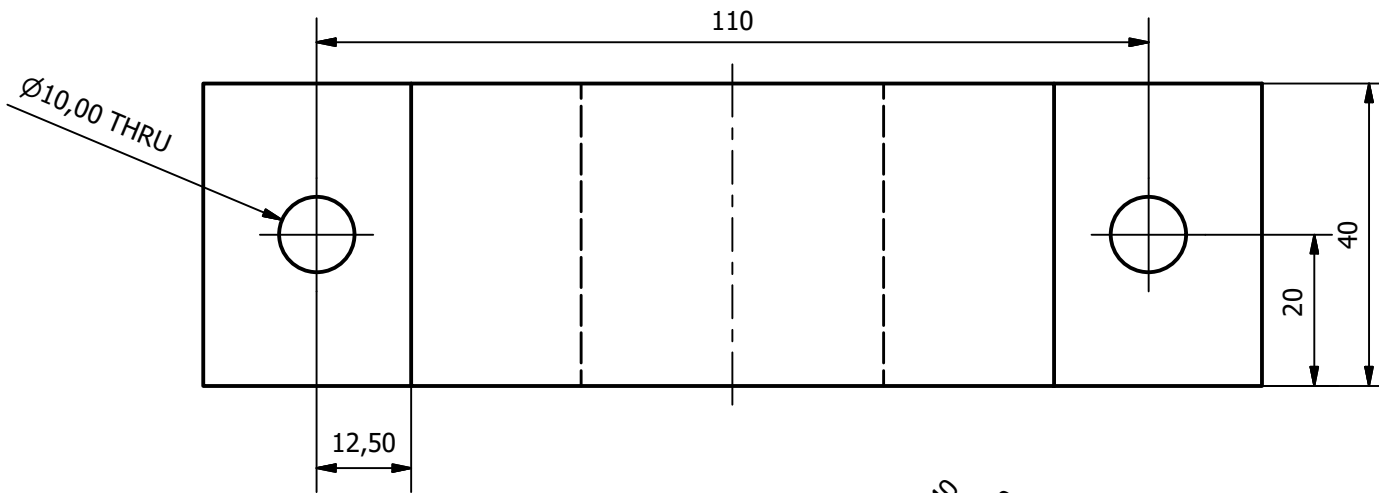

1	1	Steering Bracket	Kayu Balsa		
NO	JML	NAMA	BAHAN	UKURAN	KETERANGAN
	Skala : 1 : 1		Digambar : Faiz Evan Saputra		Keterangan :
	Satuan : mm		No. Mhs : 20150130141		
	Tanggal : 03 Agustus 2018		Diperiksa : Ir Aris Widyo N, M.T.,Ph.D		
Teknik Mesin UMY			Steering Bracket		NO : 4 A4

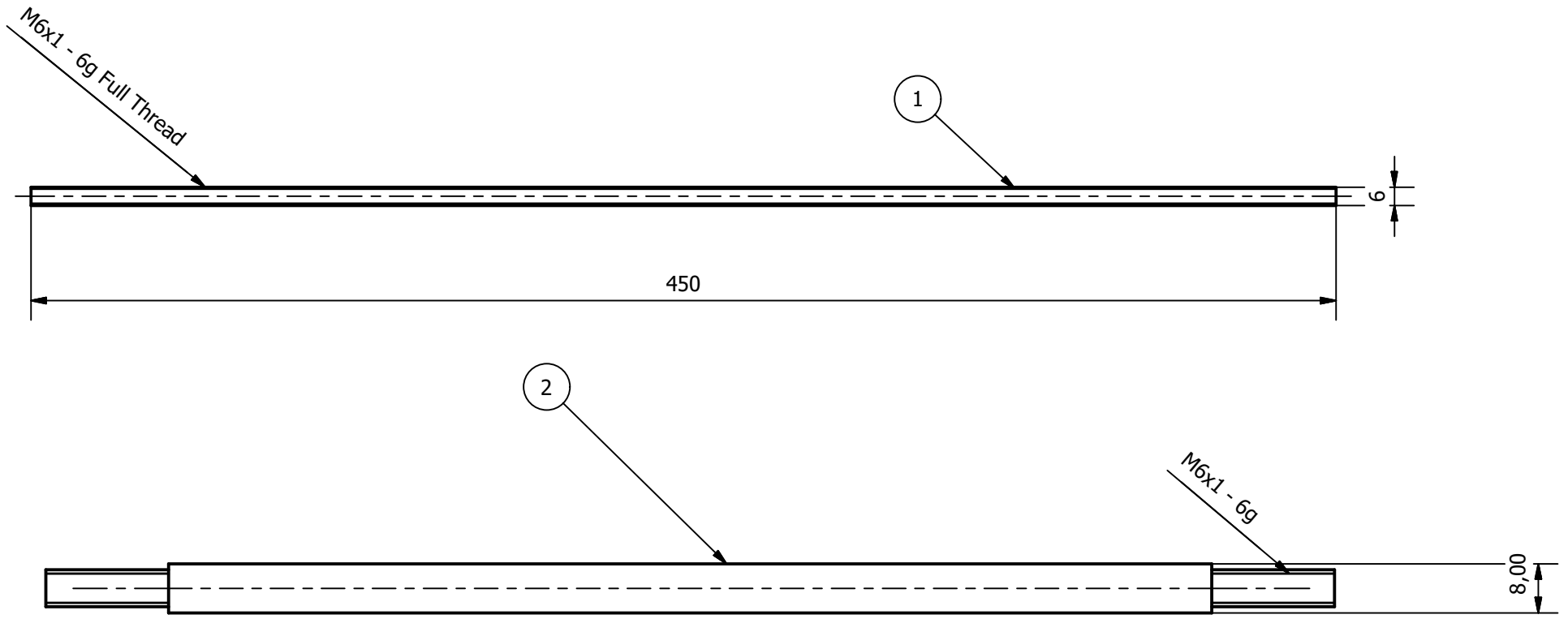

2	1	Arm Connector	Aluminium		
1	1	Tie Rod	Steel		
NO	JML	NAMA	BAHAN	UKURAN	KETERANGAN
	Skala : 1 : 1		Digambar : Faiz Evan Saputra		Keterangan :
	Satuan : mm		No. Mhs : 20150130141		
	Tanggal : 03 Agustus 2018		Diperiksa : Ir Aris Widyo N, M.T.,Ph.D		
Teknik Mesin UMY			Steering Linkage		NO : 5
					A4

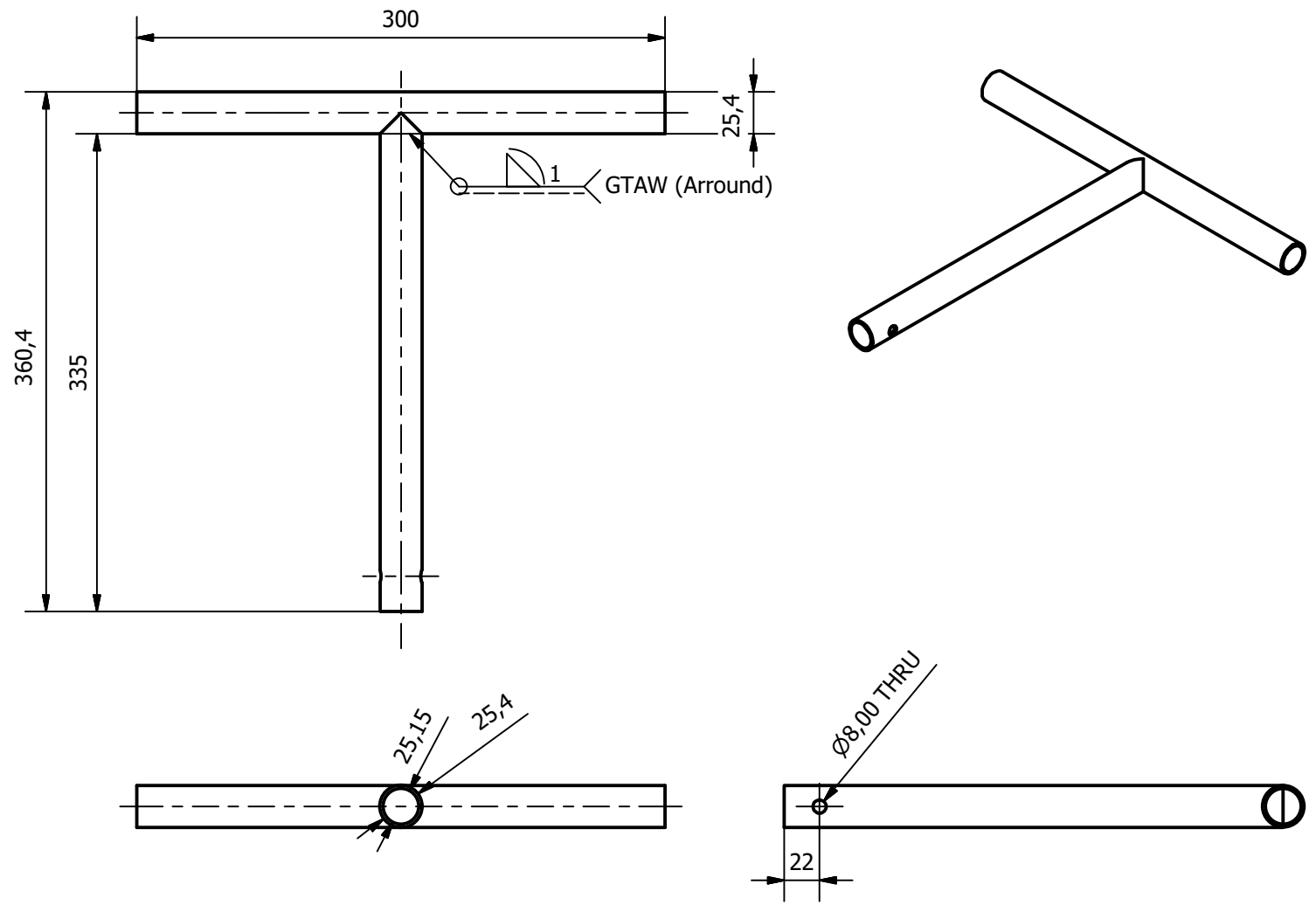

1	1	Setang	Stainless Steel		
NO	JML	NAMA	BAHAN	UKURAN	KETERANGAN
	Skala : 1 : 1		Digambar : Faiz Evan Saputra		Keterangan :
	Satuan : mm		No. Mhs : 20150130141		
	Tanggal : 03 Agustus 2018		Diperiksa : Ir Aris Widyo N, M.T.,Ph.D		
Teknik Mesin UMY			Setang		NO : 6
					A4

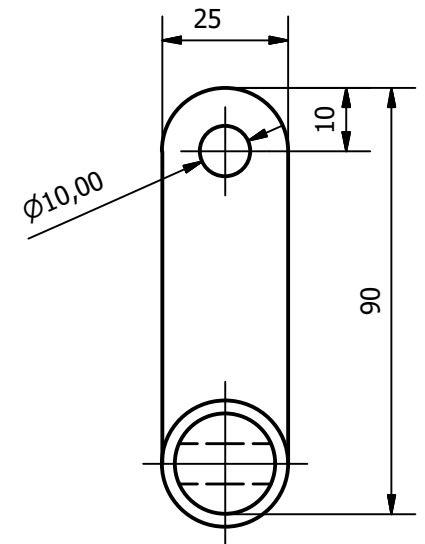
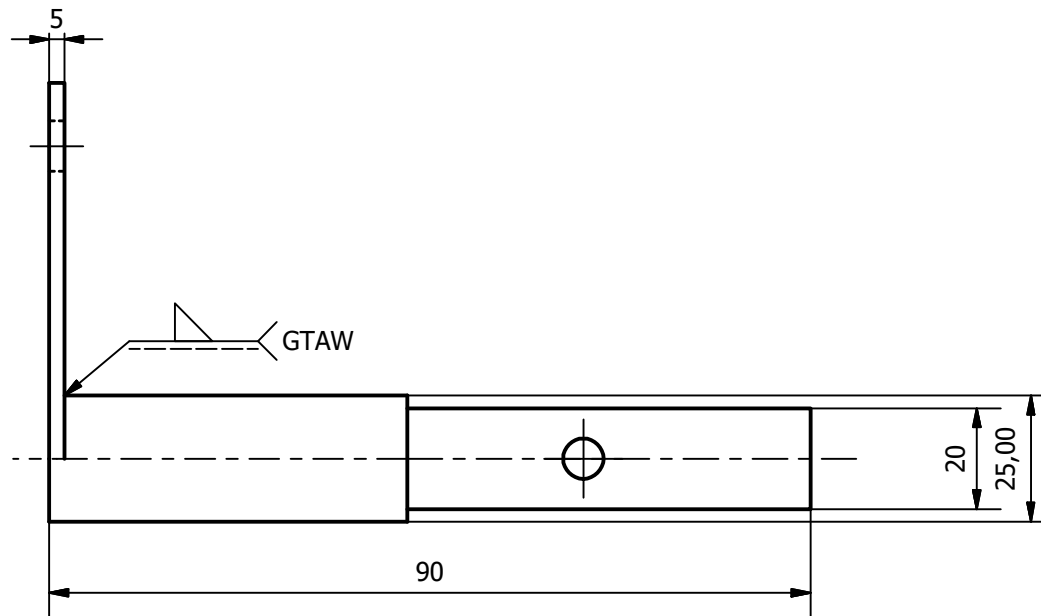
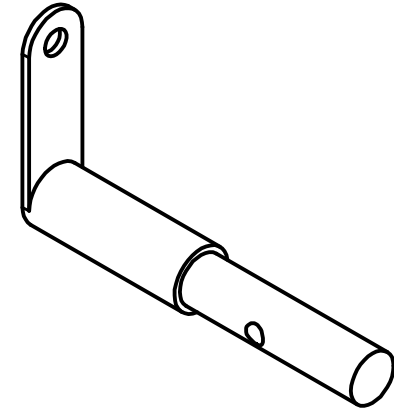
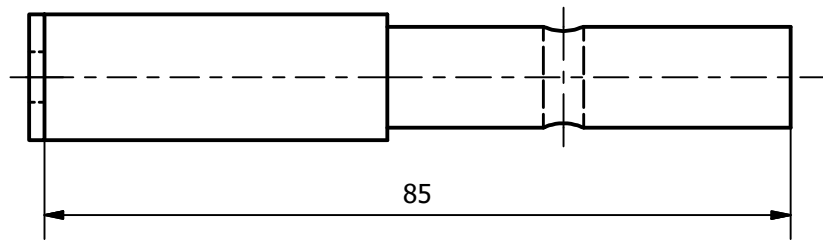

1	1	Link Penghubung	Aluminium		
NO	JML	NAMA	BAHAN	UKURAN	KETERANGAN
	Skala : 1 : 1		Digambar : Faiz Evan Saputra		Keterangan :
	Satuan : mm		No. Mhs : 20150130141		
	Tanggal : 03 Agustus 2018		Diperiksa : Ir Aris Widyo N, M.T.,Ph.D		
Teknik Mesin UMY			Penghubung Link Steering		NO : 7
					A4

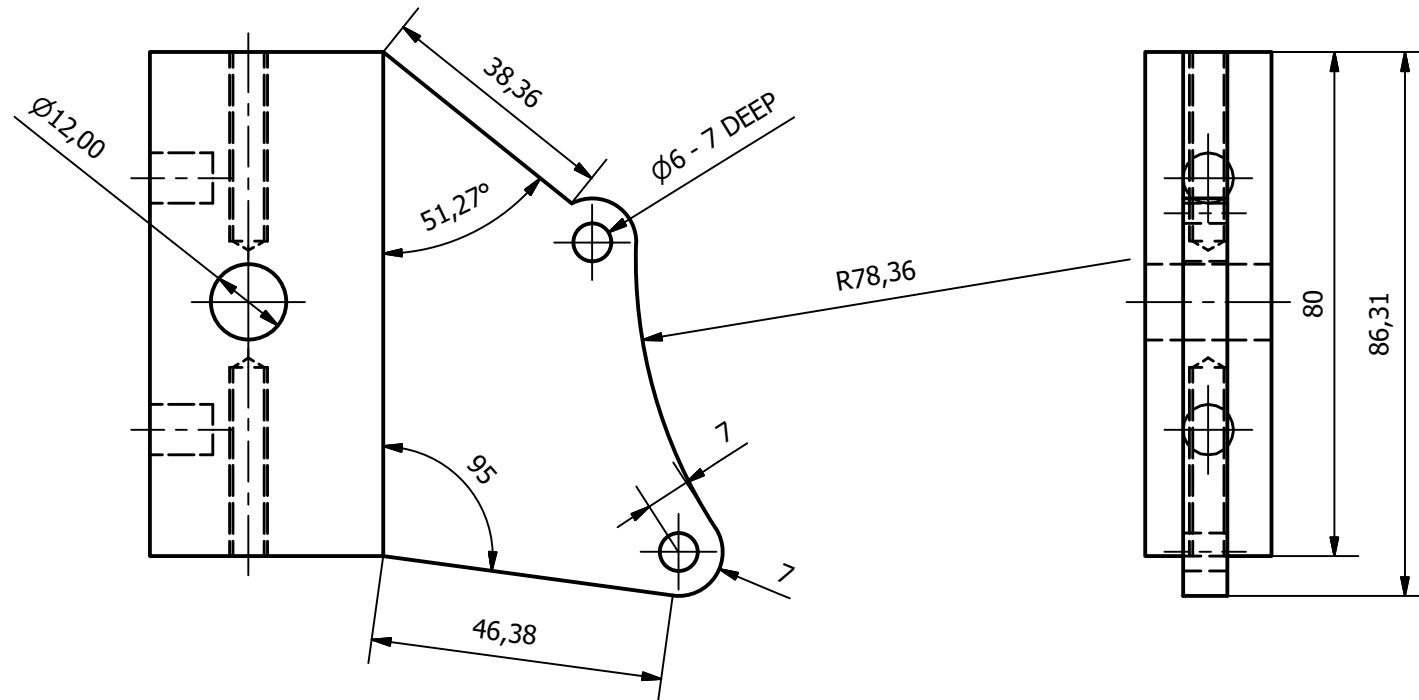
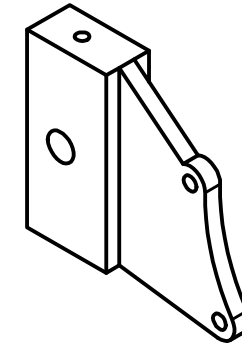
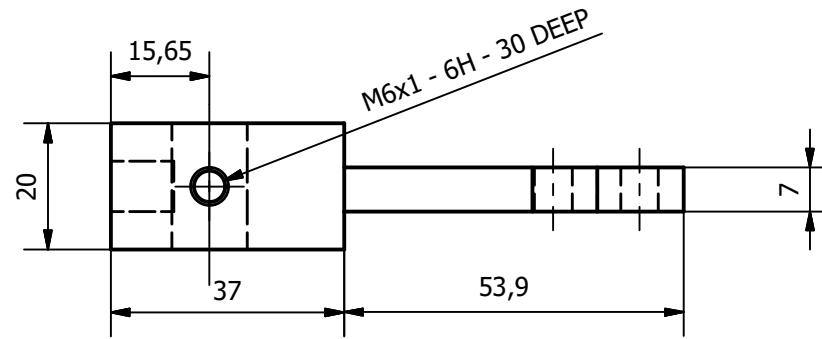

1	1	Braket Shaft Front	Aluminium 6061		
NO	JML	NAMA	BAHAN	UKURAN	KETERANGAN
	Skala : 1 : 1,2		Digambar : Faiz Evan Saputra		Keterangan :
	Satuan : mm		No. Mhs : 20150130141		
	Tanggal : 03 Agustus 2018		Diperiksa : Ir Aris Widyo N, M.T.,Ph.D		
Teknik Mesin UMY			Bracket Shaft Front		NO : 8 A4

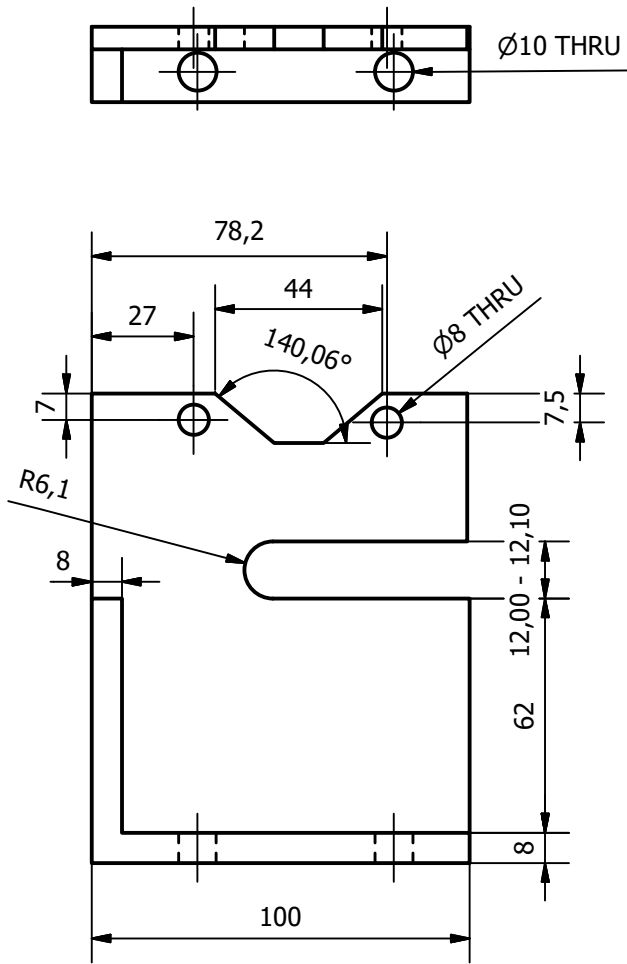

(1)

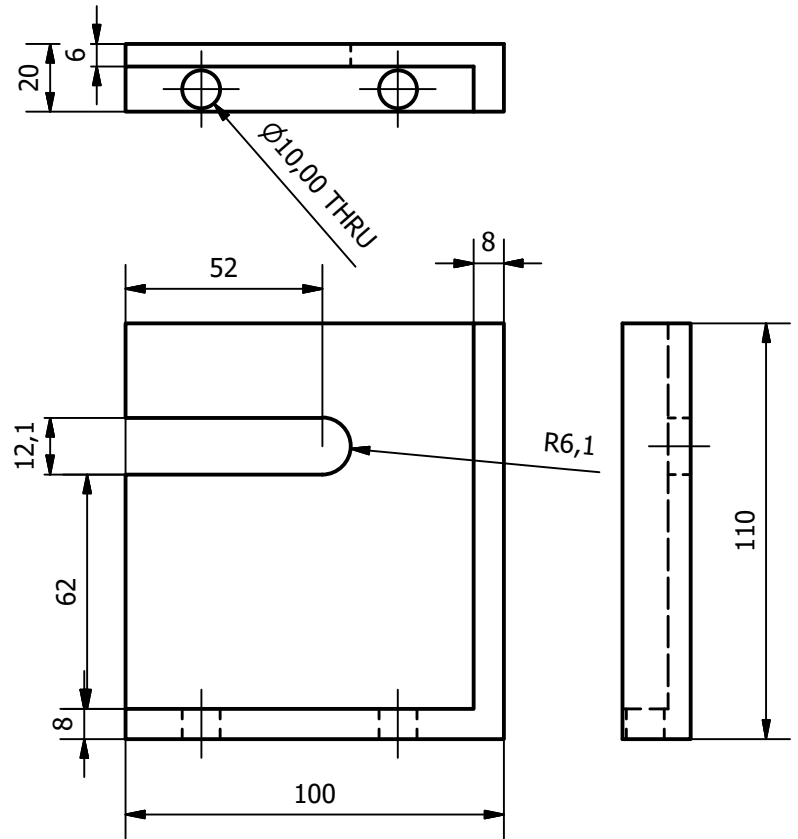
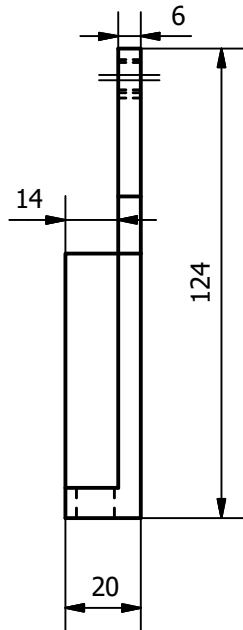

(2)

1	1	Braket Shaft Rear Right	Aluminium 5052		
1	1	Braket Shaft Rear Left	Aluminium 5052		
NO	JML	NAMA	BAHAN	UKURAN	KETERANGAN
	Skala : 1 : 2		Digambar : Faiz Evan Saputra		Keterangan :
	Satuan : mm		No. Mhs : 20150130141		
	Tanggal : 03 Agustus 2018		Diperiksa : Ir Aris Widyo N, M.T.,Ph.D		
Teknik Mesin UMY			Bracket Shaft Rear		NO : 9
					A4

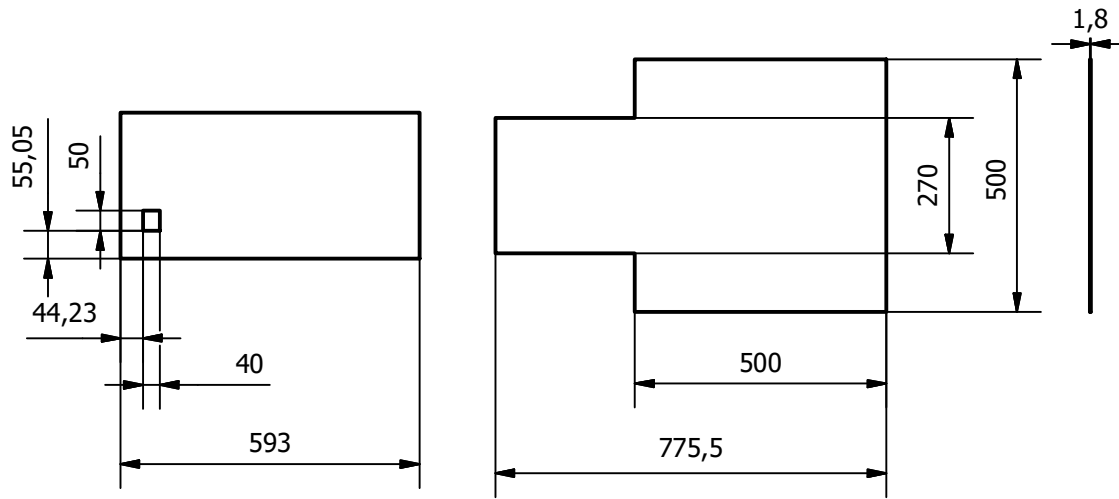

(1)

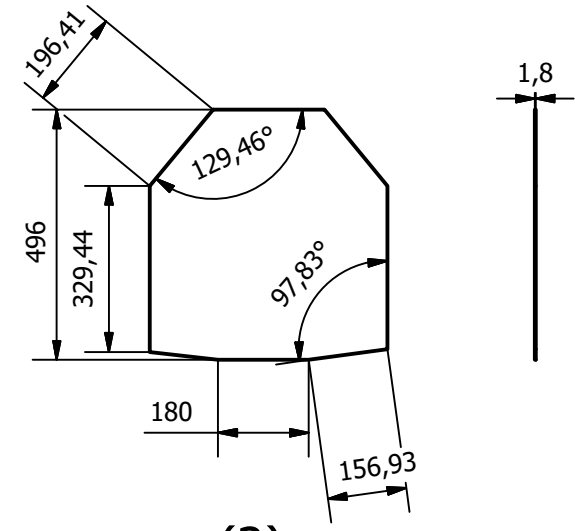

(2)

2	1	Rear Floor	Aluminium	1,8 mm	Sheet Metal
1	1	Front Floor	Aluminium	1,8 mm	Sheet Metal
NO	JML	NAMA	BAHAN	UKURAN	KETERANGAN
	Skala : 1 : 1		Digambar : Faiz Evan Saputra		Keterangan :
	Satuan : mm		No. Mhs : 20150130141		
	Tanggal : 03 Agustus 2018		Diperiksa : Ir Aris Widyo N, M.T.,Ph.D		
Teknik Mesin UMY			Floor Plate		NO : 10 A4

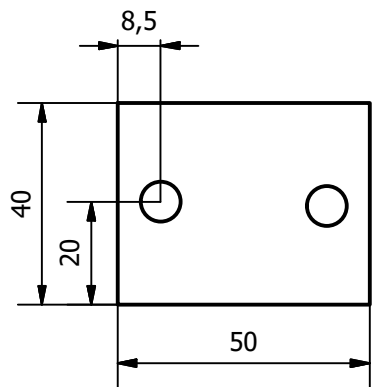

(2)

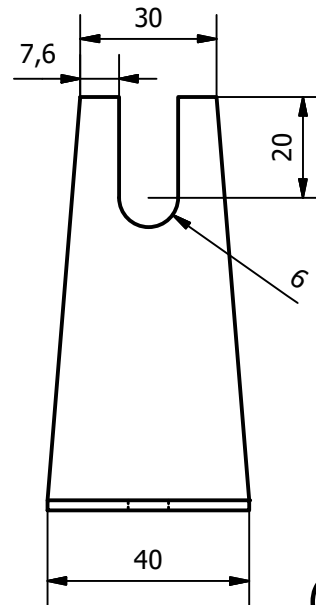
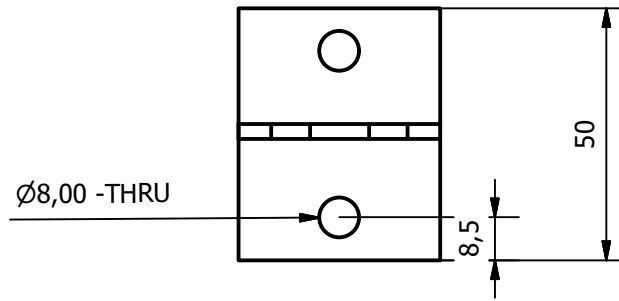
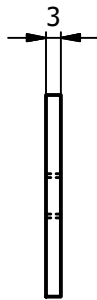

(1)

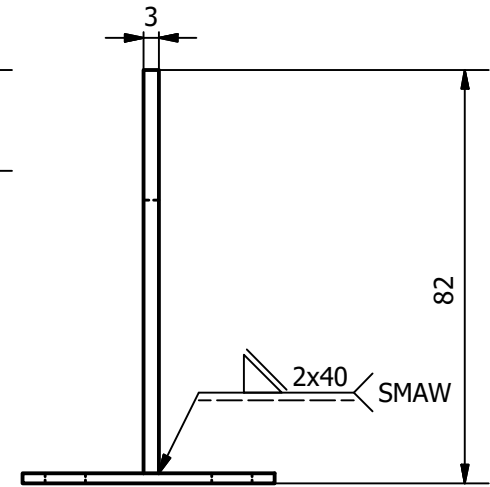

2	2	Plat Pengikat	Steel		
1	2	Bracket Motor	Steel		
NO	JML	NAMA	BAHAN	UKURAN	KETERANGAN
	Skala : 1 : 2		Digambar : Faiz Evan Saputra		Keterangan :
	Satuan : mm		No. Mhs : 20150130141		
	Tanggal : 03 Agustus 2018		Diperiksa : Ir Aris Widyo N, M.T.,Ph.D		
Teknik Mesin UMY			Bracket Motor		NO : 11 A4