

**PROGRAM ALAT SEMI-OTOMATIS PENJEMUR KERIPIK JENGKOL
BERBASIS MIKROKONTROLER ATMEGA 328**

```
#include <LiquidCrystal.h>
LiquidCrystal lcd(12,11,5,4,3,2);
int IN_1 = 7;
int IN_2 = 6;

void setup(){
  Serial.begin(9600);
  lcd.clear();
  lcd.begin(16,2);
  lcd.setCursor(0,0);
  lcd.print("Alat Penjemur");
  lcd.setCursor(0,1);
  lcd.print("Keripik: ON");
  delay(8000);
  pinMode (IN_1, OUTPUT);
  pinMode (IN_2, OUTPUT);
  pinMode (A0, INPUT);
  pinMode (A1, INPUT);
  pinMode (A2, INPUT);
}

void loop(){
  int sensorReading1 = analogRead(A0);
  float teganganhujan = sensorReading1*(5.0/1023.0);
  Serial.print("\t" "tegangan hujan= ");
  Serial.println(teganganhujan);
```

```

int sensorReading2 = analogRead(A1);
float teganganSWtutup = sensorReading2*(5.0/1023.0);
Serial.print("\t" "tegangan SWtutup=" );
Serial.println(teganganSWtutup);
int sensorReading3 = analogRead(A2);
float teganganSWbuka = sensorReading3*(5.0/1023.0);
Serial.print("\t" "tegangan SWbuka=" );
Serial.println(teganganSWbuka);
if (teganganhujan>3.00 && teganganSWtutup<3.00){
    lcd.clear();
    lcd.setCursor (0,0);
    lcd.print ("CUACA HUJAN");
    lcd.setCursor (0,1);
    lcd.print ("Menutup atap");
    digitalWrite(IN_1, HIGH);
    digitalWrite(IN_2, LOW);
}
else if (teganganhujan>3.00 && teganganSWtutup>3.00){
    lcd.clear();
    lcd.setCursor (0,0);
    lcd.print ("CUACA HUJAN");
    lcd.setCursor (0,1);
    lcd.print ("Atap Tertutup");
    digitalWrite(IN_1, LOW);
    digitalWrite(IN_2, LOW);
}
else if (teganganhujan<3.00 && teganganSWbuka<3.00){
    lcd.clear();
    lcd.setCursor (0,0);
    lcd.print ("CUACA CERAH");
    lcd.setCursor (0,1);

```



```
lcd.print ("Membuka Atap");
    digitalWrite(IN_1, LOW);
    digitalWrite(IN_2, HIGH);
}
    if (teganganhujan<3.00 && teganganSWbuka>3.00){
lcd.clear();
lcd.setCursor (0,0);
lcd.print ("CUACA CERAH");
lcd.setCursor (0,1);
lcd.print ("Menjemur Keripik");
    digitalWrite(IN_1, LOW);
    digitalWrite(IN_2, LOW);
}
}
```

Arduino Uno

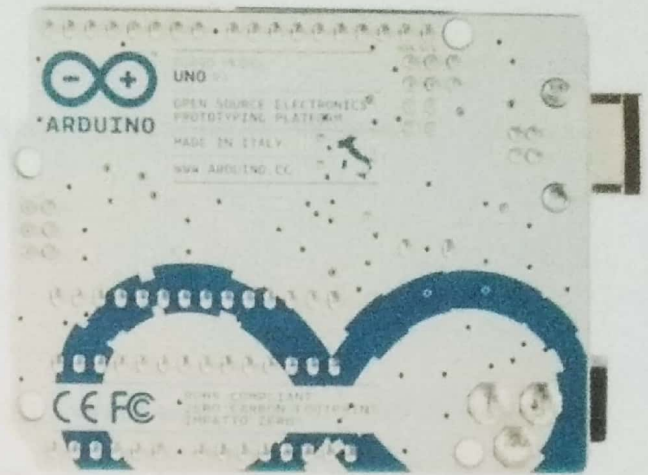
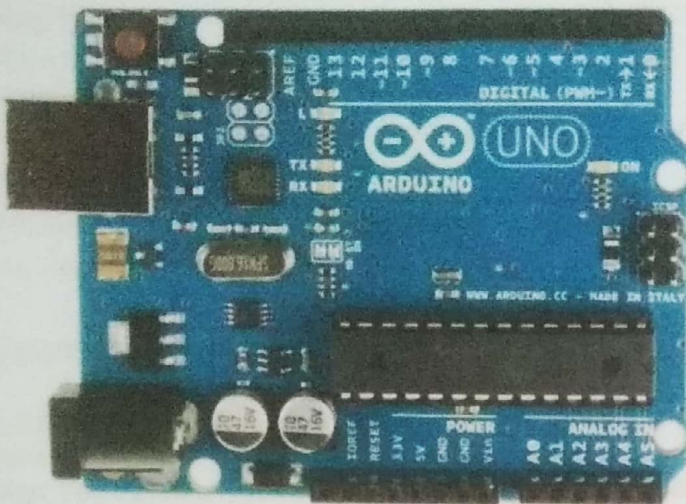

Arduino Uno R3 Front

Arduino Uno R3 Back



Arduino Uno R2 Front

Arduino Uno SMD

Arduino Uno Front

Arduino Uno Back

Overview

The Arduino Uno is a microcontroller board based on the ATmega328 ([datasheet](#)). It has 14 digital input/output pins (of which 6 can be used as PWM outputs), 6 analog inputs, a 16 MHz ceramic resonator, a USB connection, a power jack, an ICSP header, and a reset button. It contains everything needed to support the microcontroller; simply connect it to a computer with a USB cable or power it with a AC-to-DC adapter or battery to get started.

The Uno differs from all preceding boards in that it does not use the FTDI USB-to-serial driver chip. Instead, it features the Atmega16U2 (Atmega8U2 up to version R2) programmed as a USB-to-serial converter.

[Revision 2](#) of the Uno board has a resistor pulling the 8U2 HWB line to ground, making it easier to put into [DFU mode](#).

[Revision 3](#) of the board has the following new features:

- 1.0 pinout: added SDA and SCL pins that are near to the AREF pin and two other new pins placed near to the RESET pin, the IOREF that allow the shields to adapt to the voltage provided from the board. In future, shields will be compatible both with the board that use the AVR, which operate with 5V and with the Arduino Due that operate with 3.3V. The second one is a not connected pin, that is reserved for future purposes.
- Stronger RESET circuit.
- Atmega 16U2 replace the 8U2.

"Uno" means one in Italian and is named to mark the upcoming release of Arduino 1.0. The Uno and version 1.0 will be the reference versions of Arduino, moving forward. The Uno is the latest in a series of USB Arduino boards, and the reference model for the Arduino platform; for a comparison with previous versions, see the [index of Arduino boards](#).

Summary

Microcontroller	ATmega328
Operating Voltage	5V
Input Voltage (recommended)	7-12V

Input Voltage (limits)	6-20V
Digital I/O Pins	14 (of which 6 provide PWM output)
Analog Input Pins	6
DC Current per I/O Pin	40 mA
DC Current for 3.3V Pin	50 mA
Flash Memory	32 KB (ATmega328) of which 0.5 KB used by bootloader
SRAM	2 KB (ATmega328)
EEPROM	1 KB (ATmega328)
Clock Speed	16 MHz

Schematic & Reference Design

EAGLE files: [arduino-uno-Rev3-reference-design.zip](#) (NOTE: works with Eagle 6.0 and newer)

Schematic: [arduino-uno-Rev3-schematic.pdf](#)

Note: The Arduino reference design can use an Atmega8, 168, or 328, Current models use an ATmega328, but an Atmega8 is shown in the schematic for reference. The pin configuration is identical on all three processors.

Power

The Arduino Uno can be powered via the USB connection or with an external power supply. The power source is selected automatically.

External (non-USB) power can come either from an AC-to-DC adapter (wall-wart) or battery. The adapter can be connected by plugging a 2.1mm center-positive plug into the board's power jack. Leads from a battery can be inserted in the Gnd and Vin pin headers of the POWER connector.

The board can operate on an external supply of 6 to 20 volts. If supplied with less than 7V, however, the 5V pin may supply less than five volts and the board may be unstable. If using more than 12V, the voltage regulator may overheat and damage the board. The recommended range is 7 to 12 volts.

The power pins are as follows:

- **VIN.** The input voltage to the Arduino board when it's using an external power source (as opposed to 5 volts from the USB connection or other regulated power source). You can supply voltage through this pin, or, if supplying voltage via the power jack, access it through this pin.
- **5V.** This pin outputs a regulated 5V from the regulator on the board. The board can be supplied with power either from the DC power jack (7 - 12V), the USB connector (5V), or the VIN pin of the board (7-12V). Supplying voltage via the 5V or 3.3V pins bypasses the regulator, and can damage your board. We don't advise it.
- **3V3.** A 3.3 volt supply generated by the on-board regulator. Maximum current draw is 50 mA.
- **GND.** Ground pins.

Memory

The ATmega328 has 32 KB (with 0.5 KB used for the bootloader). It also has 2 KB of SRAM and 1 KB of EEPROM (which can be read and written with the [EEPROM library](#)).

Input and Output

Each of the 14 digital pins on the Uno can be used as an input or output, using [pinMode\(\)](#), [digitalWrite\(\)](#), and [digitalRead\(\)](#) functions. They operate at 5 volts. Each pin can provide or receive a maximum of 40 mA and has an internal pull-up resistor (disconnected by default) of 20-50 kOhms. In addition, some pins have specialized functions:

- **Serial: 0 (RX) and 1 (TX).** Used to receive (RX) and transmit (TX) TTL serial data. These pins are connected to the corresponding pins of the ATmega8U2 USB-to-TTL Serial chip.
- **External Interrupts: 2 and 3.** These pins can be configured to trigger an interrupt on a low value, a rising or falling edge, or a change in value. See the [attachInterrupt\(\)](#) function for details.
- **PWM: 3, 5, 6, 9, 10, and 11.** Provide 8-bit PWM output with the [analogWrite\(\)](#) function.

- **SPI: 10 (SS), 11 (MOSI), 12 (MISO), 13 (SCK).** These pins support SPI communication using the [SPI library](#).
- **LED: 13.** There is a built-in LED connected to digital pin 13. When the pin is HIGH value, the LED is on, when the pin is LOW, it's off.

The Uno has 6 analog inputs, labeled A0 through A5, each of which provide 10 bits of resolution (i.e. 1024 different values). By default they measure from ground to 5 volts, though is it possible to change the upper end of their range using the AREF pin and the [analogReference\(\)](#) function. Additionally, some pins have specialized functionality:

- **TWI: A4 or SDA pin and A5 or SCL pin.** Support TWI communication using the [Wire library](#).

There are a couple of other pins on the board:

- **AREF.** Reference voltage for the analog inputs. Used with [analogReference\(\)](#).
- **Reset.** Bring this line LOW to reset the microcontroller. Typically used to add a reset button to shields which block the one on the board.

See also the [mapping between Arduino pins and ATmega328 ports](#). The mapping for the Atmega8, 168, and 328 is identical.

Communication

The Arduino Uno has a number of facilities for communicating with a computer, another Arduino, or other microcontrollers. The ATmega328 provides UART TTL (5V) serial communication, which is available on digital pins 0 (RX) and 1 (TX). An ATmega16U2 on the board channels this serial communication over USB and appears as a virtual com port to software on the computer. The '16U2 firmware uses the standard USB COM drivers, and no external driver is needed. However, [on Windows, a .inf file is required](#). The Arduino software includes a serial monitor which allows simple textual data to be sent to and from the Arduino board. The RX and TX LEDs on the board will flash when data is being transmitted via the USB-to-serial chip and USB connection to the computer (but not for serial communication on pins 0 and 1).

A [SoftwareSerial library](#) allows for serial communication on any of the Uno's digital pins.

The ATmega328 also supports I2C (TWI) and SPI communication. The Arduino software includes a [Wire library](#) to simplify use of the I2C bus; see the [documentation](#) for details. For SPI communication, use the [SPI library](#).

Programming

The Arduino Uno can be programmed with the Arduino software ([download](#)). Select "Arduino Uno from the **Tools > Board** menu (according to the microcontroller on your board). For details, see the [reference](#) and [tutorials](#).

The ATmega328 on the Arduino Uno comes preburned with a [bootloader](#) that allows you to upload new code to it without the use of an external hardware programmer. It communicates using the original STK500 protocol ([reference](#), [C header files](#)).

You can also bypass the bootloader and program the microcontroller through the ICSP (In-Circuit Serial Programming) header; see [these instructions](#) for details.

The ATmega16U2 (or 8U2 in the rev1 and rev2 boards) firmware source code is available. The ATmega16U2/8U2 is loaded with a DFU bootloader, which can be activated by:

- On Rev1 boards: connecting the solder jumper on the back of the board (near the map of Italy) and then resetting the 8U2.
- On Rev2 or later boards: there is a resistor that pulling the 8U2/16U2 HWB line to ground, making it easier to put into DFU mode.

You can then use [Atmel's FLIP software](#) (Windows) or the [DFU programmer](#) (Mac OS X and Linux) to load a new firmware. Or you can use the ISP header with an external programmer (overwriting the DFU bootloader). See [this user-contributed tutorial](#) for more information.

Automatic (Software) Reset

Rather than requiring a physical press of the reset button before an upload, the Arduino Uno is designed in a way that allows it to be reset by software running on a connected computer. One of the hardware flow control lines (DTR) of the ATmega8U2/16U2 is connected to the reset line of the ATmega328 via a 100 nanofarad capacitor. When this line is asserted (taken low), the reset line drops long enough to reset the chip. The Arduino software uses this capability to allow you to upload code by simply pressing the upload button in the Arduino environment. This means that the bootloader can have a shorter timeout, as the lowering of DTR can be well-coordinated with the start of the upload. This setup has other implications. When the Uno is connected to either a computer running Mac OS X or Linux, it resets each time a connection is made to it from software (via USB). For the following half-second or so, the bootloader is running on the Uno. While it is programmed to ignore malformed data (i.e. anything besides an upload of new code), it will intercept the first few bytes of data sent to the board after a connection is opened. If a sketch running on the board receives one-time configuration or other data when it first starts, make sure that the software with which it communicates waits a second after opening the connection and before sending this data.

The Uno contains a trace that can be cut to disable the auto-reset. The pads on either side of the trace can be soldered together to re-enable it. It's labeled "RESET-EN". You may also be able to disable the auto-reset by connecting a 110 ohm resistor from 5V to the reset line; see [this forum thread](#) for details.

USB Overcurrent Protection

The Arduino Uno has a resettable polyfuse that protects your computer's USB ports from shorts and overcurrent. Although most computers provide their own internal protection, the fuse provides an extra layer of protection. If more than 500 mA is applied to the USB port, the fuse will automatically break the connection until the short or overload is removed.

Physical Characteristics

The maximum length and width of the Uno PCB are 2.7 and 2.1 inches respectively, with the USB connector and power jack extending beyond the former dimension. Four screw holes allow the board to be attached to a surface or case. Note that the distance between digital pins 7 and 8 is 160 mil (0.16"), not an even multiple of the 100 mil spacing of the other pins.

Features

- High Performance, Low Power AVR[®] 8-Bit Microcontroller
- Advanced RISC Architecture
 - 131 Powerful Instructions – Most Single Clock Cycle Execution
 - 32 x 8 General Purpose Working Registers
 - Fully Static Operation
 - Up to 20 MIPS Throughput at 20 MHz
 - On-chip 2-cycle Multiplier
- High Endurance Non-volatile Memory Segments
 - 4/8/16/32K Bytes of In-System Self-Programmable Flash program memory (ATmega48PA/88PA/168PA/328P)
 - 256/512/512/1K Bytes EEPROM (ATmega48PA/88PA/168PA/328P)
 - 512/1K/1K/2K Bytes Internal SRAM (ATmega48PA/88PA/168PA/328P)
 - Write/Erase Cycles: 10,000 Flash/100,000 EEPROM
 - Data retention: 20 years at 85°C/100 years at 25°C⁽¹⁾
 - Optional Boot Code Section with Independent Lock Bits
 - In-System Programming by On-chip Boot Program
 - True Read-While-Write Operation
 - Programming Lock for Software Security
- Peripheral Features
 - Two 8-bit Timer/Counters with Separate Prescaler and Compare Mode
 - One 16-bit Timer/Counter with Separate Prescaler, Compare Mode, and Capture Mode
 - Real Time Counter with Separate Oscillator
 - Six PWM Channels
 - 8-channel 10-bit ADC in TQFP and QFN/MLF package
 - Temperature Measurement
 - 6-channel 10-bit ADC in PDIP Package
 - Temperature Measurement
 - Programmable Serial USART
 - Master/Slave SPI Serial Interface
 - Byte-oriented 2-wire Serial Interface (Philips I²C compatible)
 - Programmable Watchdog Timer with Separate On-chip Oscillator
 - On-chip Analog Comparator
 - Interrupt and Wake-up on Pin Change
- Special Microcontroller Features
 - Power-on Reset and Programmable Brown-out Detection
 - Internal Calibrated Oscillator
 - External and Internal Interrupt Sources
 - Six Sleep Modes: Idle, ADC Noise Reduction, Power-save, Power-down, Standby, and Extended Standby
- I/O and Packages
 - 23 Programmable I/O Lines
 - 28-pin PDIP, 32-lead TQFP, 28-pad QFN/MLF and 32-pad QFN/MLF
- Operating Voltage:
 - 1.8 - 5.5V for ATmega48PA/88PA/168PA/328P
- Temperature Range:
 - -40°C to 85°C
- Speed Grade:
 - 0 - 20 MHz @ 1.8 - 5.5V
- Low Power Consumption at 1 MHz, 1.8V, 25°C for ATmega48PA/88PA/168PA/328P:
 - Active Mode: 0.2 mA
 - Power-down Mode: 0.1 µA
 - Power-save Mode: 0.75 µA (Including 32 kHz RTC)



8-bit **AVR[®]**
Microcontroller
with 4/8/16/32K
Bytes In-System
Programmable
Flash

ATmega48PA
ATmega88PA
ATmega168PA
ATmega328P

Summary

Rev. 8161CS-AVR-05/09



1. Pin Configurations

Figure 1-1. Pinout ATmega48PA/88PA/168PA/328P

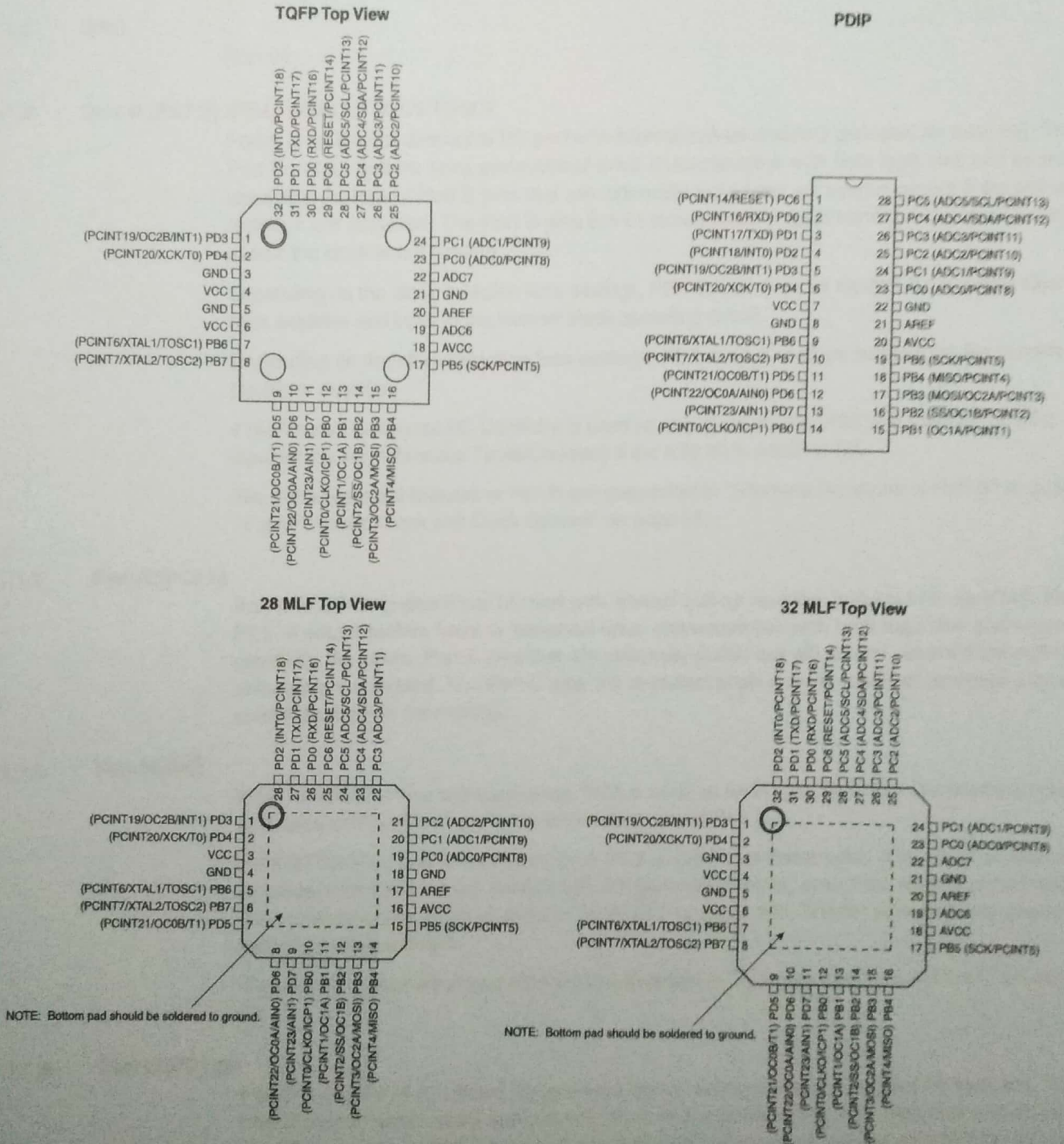

1.1 Pin Descriptions

1.1.1 VCC

Digital supply voltage.

1.1.2 GND

Ground.

1.1.3 Port B (PB7:0) XTAL1/XTAL2/TOSC1/TOSC2

Port B is an 8-bit bi-directional I/O port with internal pull-up resistors (selected for each bit). The Port B output buffers have symmetrical drive characteristics with both high sink and source capability. As inputs, Port B pins that are externally pulled low will source current if the pull-up resistors are activated. The Port B pins are tri-stated when a reset condition becomes active, even if the clock is not running.

Depending on the clock selection fuse settings, PB6 can be used as input to the inverting Oscillator amplifier and input to the internal clock operating circuit.

Depending on the clock selection fuse settings, PB7 can be used as output from the inverting Oscillator amplifier.

If the Internal Calibrated RC Oscillator is used as chip clock source, PB7..6 is used as TOSC2..1 input for the Asynchronous Timer/Counter2 if the AS2 bit in ASSR is set.

The various special features of Port B are elaborated in "Alternate Functions of Port B" on page 76 and "System Clock and Clock Options" on page 26.

1.1.4 Port C (PC5:0)

Port C is a 7-bit bi-directional I/O port with internal pull-up resistors (selected for each bit). The PC5..0 output buffers have symmetrical drive characteristics with both high sink and source capability. As inputs, Port C pins that are externally pulled low will source current if the pull-up resistors are activated. The Port C pins are tri-stated when a reset condition becomes active, even if the clock is not running.

1.1.5 PC6/RESET

If the RSTDISBL Fuse is programmed, PC6 is used as an I/O pin. Note that the electrical characteristics of PC6 differ from those of the other pins of Port C.

If the RSTDISBL Fuse is unprogrammed, PC6 is used as a Reset input. A low level on this pin for longer than the minimum pulse length will generate a Reset, even if the clock is not running. The minimum pulse length is given in Table 28-3 on page 308. Shorter pulses are not guaranteed to generate a Reset.

The various special features of Port C are elaborated in "Alternate Functions of Port C" on page 79.

1.1.6 Port D (PD7:0)

Port D is an 8-bit bi-directional I/O port with internal pull-up resistors (selected for each bit). The Port D output buffers have symmetrical drive characteristics with both high sink and source capability. As inputs, Port D pins that are externally pulled low will source current if the pull-up resistors are activated. The Port D pins are tri-stated when a reset condition becomes active, even if the clock is not running.

The various special features of Port D are elaborated in "Alternate Functions of Port D" on page 82.

1.1.7 AV_{CC}

AV_{CC} is the supply voltage pin for the A/D Converter, PC3:0, and ADC7:6. It should be externally connected to V_{CC} , even if the ADC is not used. If the ADC is used, it should be connected to V_{CC} through a low-pass filter. Note that PC6..4 use digital supply voltage, V_{CC} .

1.1.8 AREF

AREF is the analog reference pin for the A/D Converter.

1.1.9 ADC7:6 (TQFP and QFN/MLF Package Only)

In the TQFP and QFN/MLF package, ADC7:6 serve as analog inputs to the A/D converter. These pins are powered from the analog supply and serve as 10-bit ADC channels.

2. Overview

The ATmega48PA/88PA/168PA/328P is a low-power CMOS 8-bit microcontroller based on the AVR enhanced RISC architecture. By executing powerful instructions in a single clock cycle, the ATmega48PA/88PA/168PA/328P achieves throughputs approaching 1 MIPS per MHz allowing the system designer to optimize power consumption versus processing speed.

2.1 Block Diagram

Figure 2-1. Block Diagram

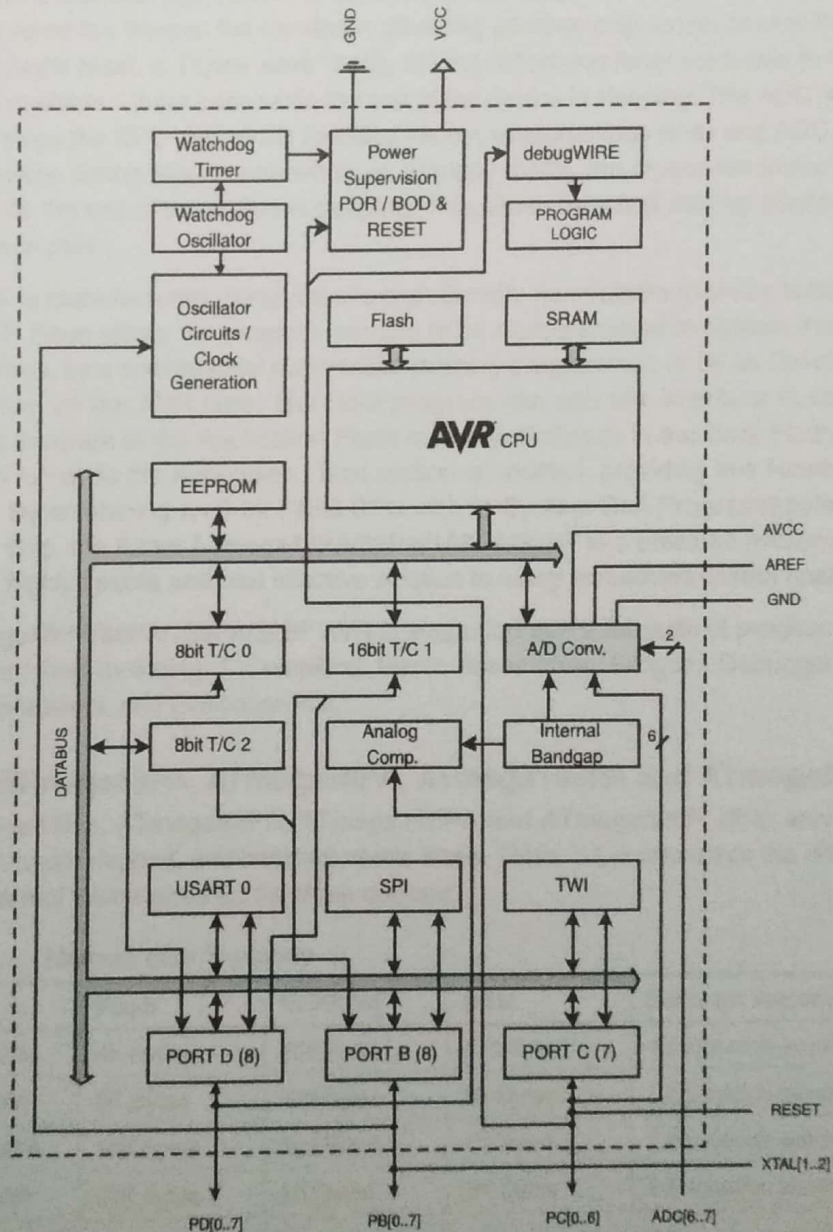

The AVR core combines a rich instruction set with 32 general purpose working registers. All the 32 registers are directly connected to the Arithmetic Logic Unit (ALU), allowing two independent registers to be accessed in one single instruction executed in one clock cycle. The resulting

architecture is more code efficient while achieving throughputs up to ten times faster than conventional CISC microcontrollers.

The ATmega48PA/88PA/168PA/328P provides the following features: 4/8/16/32K bytes of In-System Programmable Flash with Read-While-Write capabilities, 256/512/512/1K bytes EEPROM, 512/1K/1K/2K bytes SRAM, 23 general purpose I/O lines, 32 general purpose working registers, three flexible Timer/Counters with compare modes, internal and external interrupts, a serial programmable USART, a byte-oriented 2-wire Serial Interface, an SPI serial port, a 6-channel 10-bit ADC (8 channels in TQFP and QFN/MLF packages), a programmable Watchdog Timer with internal Oscillator, and five software selectable power saving modes. The Idle mode stops the CPU while allowing the SRAM, Timer/Counters, USART, 2-wire Serial Interface, SPI port, and interrupt system to continue functioning. The Power-down mode saves the register contents but freezes the Oscillator, disabling all other chip functions until the next interrupt or hardware reset. In Power-save mode, the asynchronous timer continues to run, allowing the user to maintain a timer base while the rest of the device is sleeping. The ADC Noise Reduction mode stops the CPU and all I/O modules except asynchronous timer and ADC, to minimize switching noise during ADC conversions. In Standby mode, the crystal/resonator Oscillator is running while the rest of the device is sleeping. This allows very fast start-up combined with low power consumption.

The device is manufactured using Atmel's high density non-volatile memory technology. The On-chip ISP Flash allows the program memory to be reprogrammed In-System through an SPI serial interface, by a conventional non-volatile memory programmer, or by an On-chip Boot program running on the AVR core. The Boot program can use any interface to download the application program in the Application Flash memory. Software in the Boot Flash section will continue to run while the Application Flash section is updated, providing true Read-While-Write operation. By combining an 8-bit RISC CPU with In-System Self-Programmable Flash on a monolithic chip, the Atmel ATmega48PA/88PA/168PA/328P is a powerful microcontroller that provides a highly flexible and cost effective solution to many embedded control applications.

The ATmega48PA/88PA/168PA/328P AVR is supported with a full suite of program and system development tools including: C Compilers, Macro Assemblers, Program Debugger/Simulators, In-Circuit Emulators, and Evaluation kits.

2.2 Comparison Between ATmega48PA, ATmega88PA, ATmega168PA and ATmega328P

The ATmega48PA, ATmega88PA, ATmega168PA and ATmega328P differ only in memory sizes, boot loader support, and interrupt vector sizes. Table 2-1 summarizes the different memory and interrupt vector sizes for the three devices.

Table 2-1. Memory Size Summary

Device	Flash	EEPROM	RAM	Interrupt Vector Size
ATmega48PA	4K Bytes	256 Bytes	512 Bytes	1 instruction word/vector
ATmega88PA	8K Bytes	512 Bytes	1K Bytes	1 instruction word/vector
ATmega168PA	16K Bytes	512 Bytes	1K Bytes	2 instruction words/vector
ATmega328P	32K Bytes	1K Bytes	2K Bytes	2 instruction words/vector

ATmega88PA, ATmega168PA and ATmega328P support a real Read-While-Write Self-Programming mechanism. There is a separate Boot Loader Section, and the SPM instruction can only execute from there. In ATmega48PA, there is no Read-While-Write support and no separate Boot Loader Section. The SPM instruction can execute from the entire Flash.

3. Resources

A comprehensive set of development tools, application notes and datasheets are available for download on <http://www.atmel.com/avr>.

4. Data Retention

Reliability Qualification results show that the projected data retention failure rate is much less than 1 PPM over 20 years at 85°C or 100 years at 25°C.

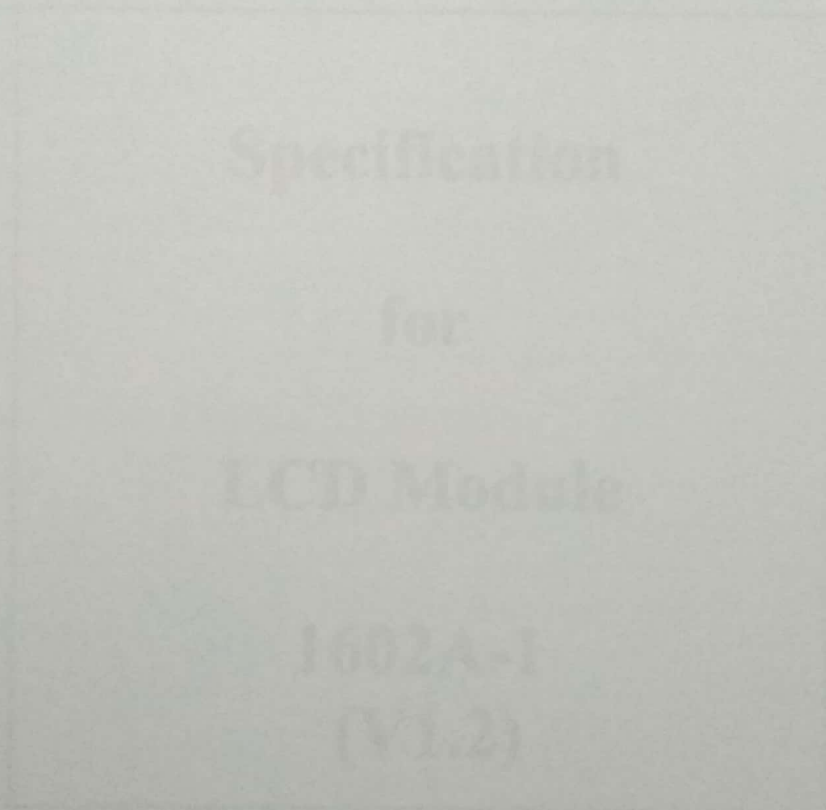

Specification

for

LCD Module

1602A-1

(V1.2)

1.0 FEATURES

- Display Mode: STN, BLUB
- Display Formate: 16 Character x 2 Line
- Viewing Direction: 6 O'Clock
- Input Data: 4-Bits or 8-Bits interface available
- Display Font : 5 x 8 Dots
- Power Supply : Single Power Supply (5V±10%)
- Driving Scheme : 1/16Duty,1/5Bias
- Backlight (Side) : LED (Yellow)

2.0 ABSOLUTE MAXIMUM

Item	Symbol	Min.	Max.	Unit
Power Supply for logic	Vdd	-0.3	+7.0	V
Power supply for LCD Drive	Vlcd	Vdd-10.0	Vdd+0.3	V
Input Voltage	Vi	-0.3	Vdd+0.3	V
Operating Temperature	Ta	0	+50	°C
Storage Temperature	Tstg	-10	+60	°C

3.0 ELECTRICAL CHARACTERISTICS

(Ta=25°C; Vdd=3.0V±10%, otherwise specified)

Item	Symbol	Test Condition	Min.	Typ.	Max.	Unit
Power Supply for Logic	Vdd	--	4.7	5.0	5.5	V
Operating Voltage for LCD	Vdd-Vo	--	--	5.0	--	V
Input High voltage	Vih	--	2.2	--	Vdd	V
Input Low voltage	Vil	--	-0.3	--	0.6	V
Output High voltage	Voh	-Ioh=0.2mA	2.4	--	--	V
Output Low voltage	Vol	Iol=1.2mA	--	--	0.4	V
Power supply current	Idd	Vdd=3.0v	--	1.1	--	mA

4.0 MECHANICAL PARAMETERS

Item	Description	Unit
PCB Dimension	80.0*36.0*1.6	mm
View Dimension	69.5*14.5	mm

5.0 PIN ASSIGNMENT

No.	Symbol	Level	Function
1	Vss	--	0V
2	Vdd	--	+5V
3	V0	--	for LCD
4	RS	H/L	Register Select: H:Data Input L:Instruction Input
5	R/W	H/L	H--Read L--Write
6	E	H,H-L	Enable Signal
7	DB0	H/L	Data bus used in 8 bit transfer
8	DB1	H/L	
9	DB2	H/L	
10	DB3	H/L	
11	DB4	H/L	Data bus for both 4 and 8 bit transfer
12	DB5	H/L	
13	DB6	H/L	
14	DB7	H/L	
15	BLA	--	BACKLIGHT +5V
16	BLK	--	BACKLIGHT 0V-

6.0 BLOCK DIAGRAM

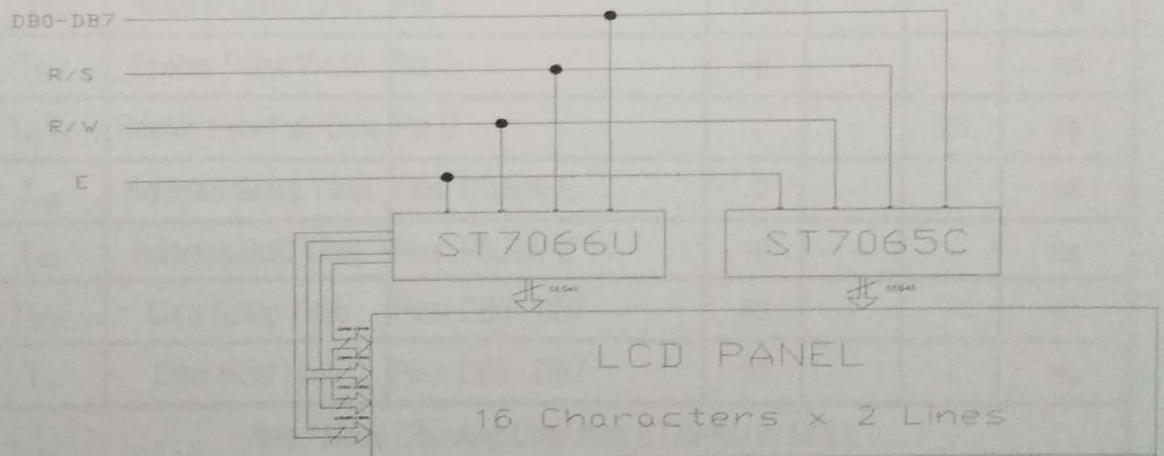

7.0 POWER SUPPLY BLOCK DIAGRAM

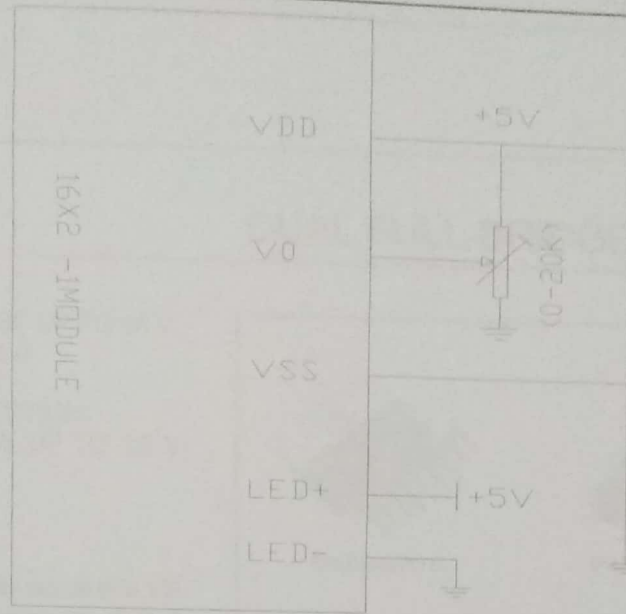

8.0 TIMING CHARACTERISTICS

Write Mode (Writing data from MPU to ST7066U)						
T_C	Enable Cycle Time	Pin E	1200	-	-	ns
T_{PW}	Enable Pulse Width	Pin E	140	-	-	ns
T_R, T_F	Enable Rise/Fall Time	Pin E	-	-	25	ns
T_{AS}	Address Setup Time	Pins: RS, RW, E	0	-	-	ns
T_{AH}	Address Hold Time	Pins: RS, RW, E	10	-	-	ns
T_{DSW}	Data Setup Time	Pins: DB0 - DB7	40	-	-	ns
T_H	Data Hold Time	Pins: DB0 - DB7	10	-	-	ns
Read Mode (Reading Data from ST7066U to MPU)						
T_C	Enable Cycle Time	Pin E	1200	-	-	ns
T_{PW}	Enable Pulse Width	Pin E	140	-	-	ns
T_R, T_F	Enable Rise/Fall Time	Pin E	-	-	25	ns
T_{AS}	Address Setup Time	Pins: RS, RW, E	0	-	-	ns
T_{AH}	Address Hold Time	Pins: RS, RW, E	10	-	-	ns
T_{DDR}	Data Setup Time	Pins: DB0 - DB7	-	-	100	ns
T_H	Data Hold Time	Pins: DB0 - DB7	10	-	-	ns

DUAL FULL-BRIDGE DRIVER

- OPERATING SUPPLY VOLTAGE UP TO 46 V
- TOTAL DC CURRENT UP TO 4 A
- LOW SATURATION VOLTAGE
- OVERTEMPERATURE PROTECTION
- LOGICAL "0" INPUT VOLTAGE UP TO 1.5 V (HIGH NOISE IMMUNITY)

DESCRIPTION

The L298 is an integrated monolithic circuit in a 15-lead Multiwatt and PowerSO20 packages. It is a high voltage, high current dual full-bridge driver designed to accept standard TTL logic levels and drive inductive loads such as relays, solenoids, DC and stepping motors. Two enable inputs are provided to enable or disable the device independently of the input signals. The emitters of the lower transistors of each bridge are connected together and the corresponding external terminal can be used for the connection of an external sensing resistor. An additional supply input is provided so that the logic works at a lower voltage.

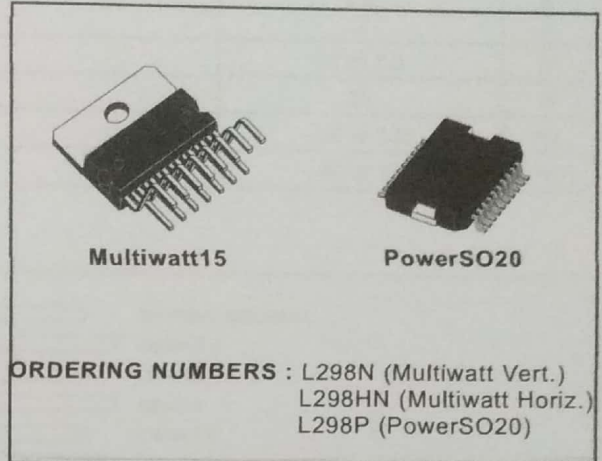

nection of an external sensing resistor. An additional supply input is provided so that the logic works at a lower voltage.

BLOCK DIAGRAM

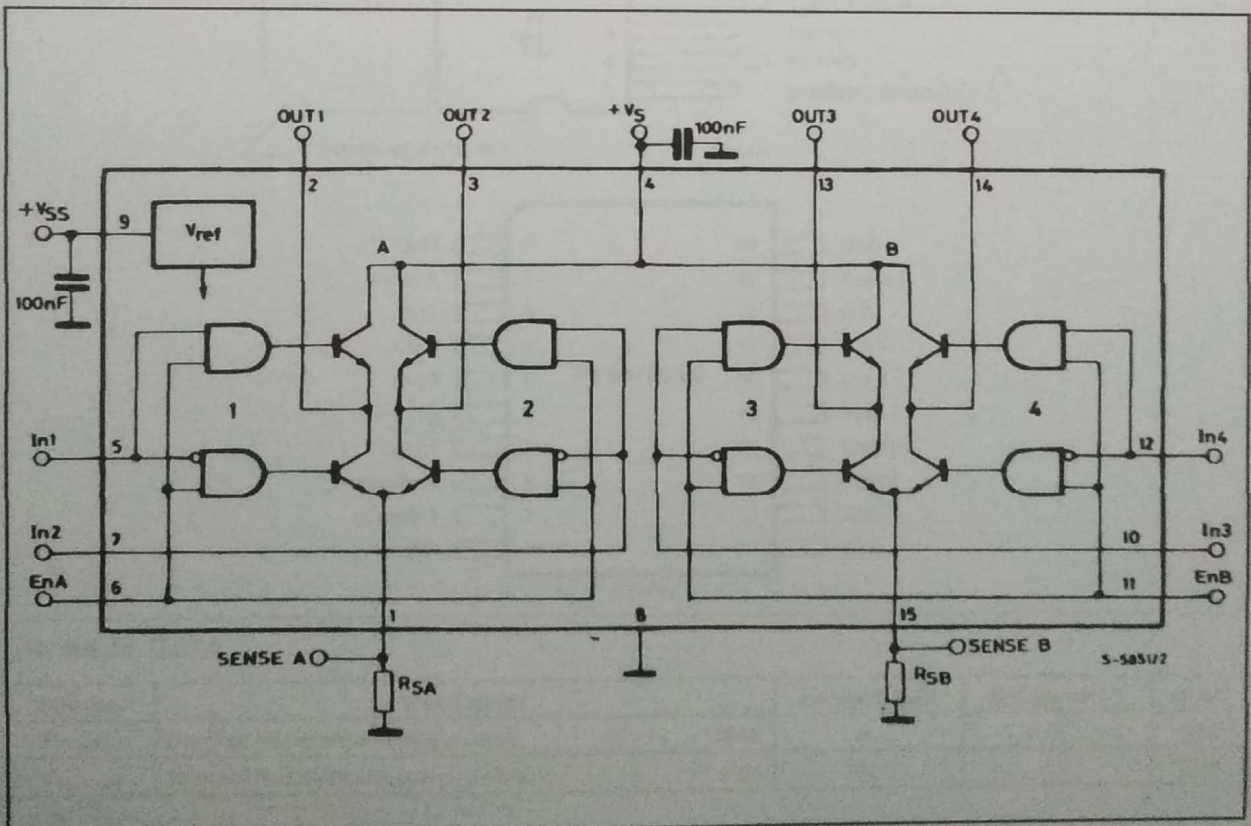

ABSOLUTE MAXIMUM RATINGS

Symbol	Parameter	Value	Unit
V_S	Power Supply	50	V
V_{SS}	Logic Supply Voltage	7	V
V_I, V_{en}	Input and Enable Voltage	-0.3 to 7	V
I_O	Peak Output Current (each Channel)		
	- Non Repetitive ($t = 100\mu s$)	3	A
	- Repetitive (80% on -20% off; $t_{on} = 10ms$)	2.5	A
	-DC Operation	2	A
V_{sens}	Sensing Voltage	-1 to 2.3	V
P_{tot}	Total Power Dissipation ($T_{case} = 75^\circ C$)	25	W
T_{op}	Junction Operating Temperature	-25 to 130	$^\circ C$
T_{stg}, T_j	Storage and Junction Temperature	-40 to 150	$^\circ C$

PIN CONNECTIONS (top view)

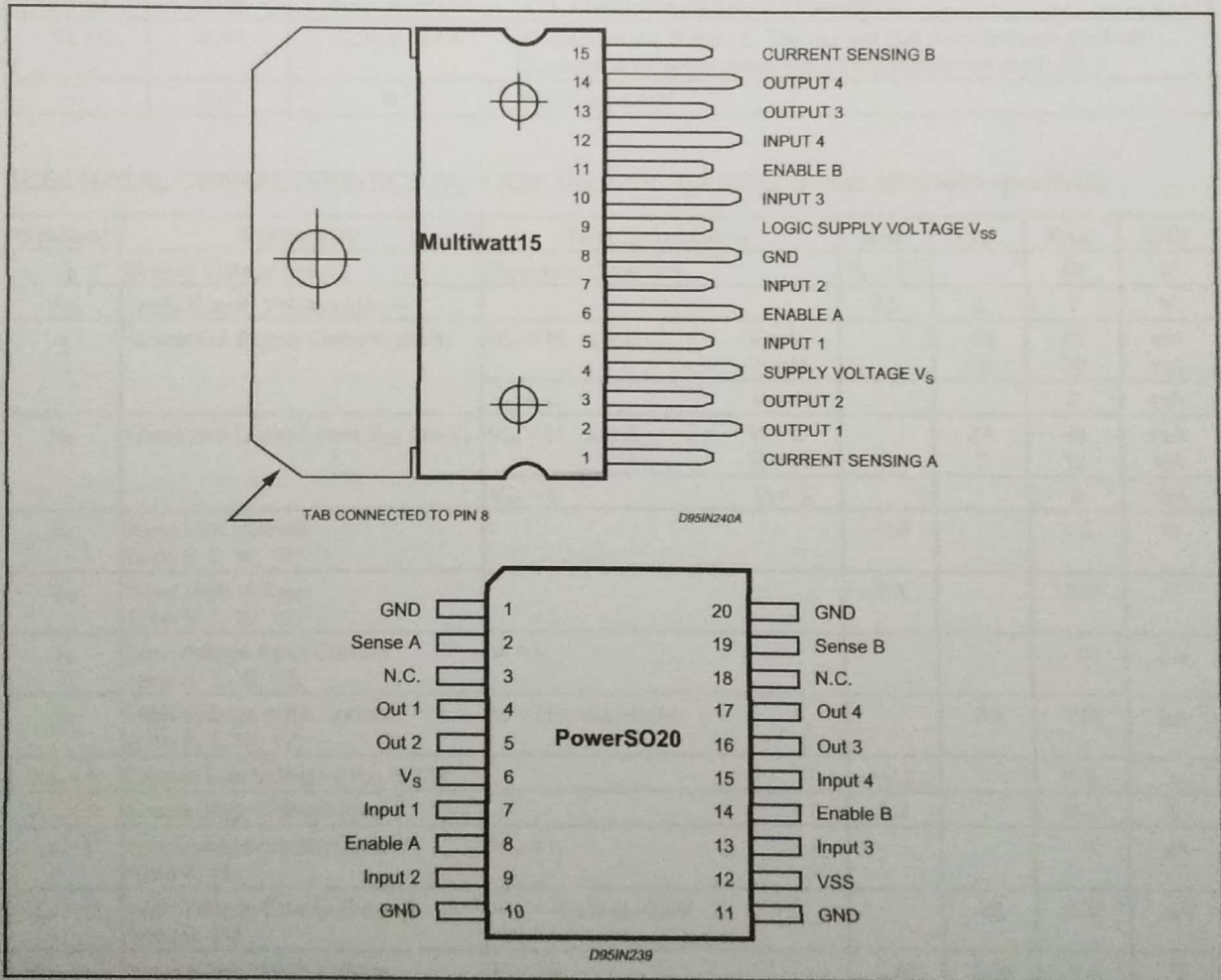

THERMAL DATA

Symbol	Parameter		PowerSO20	Multiwatt15	Unit
$R_{th j-case}$	Thermal Resistance Junction-case	Max.	-	3	$^\circ C/W$
$R_{th j-amb}$	Thermal Resistance Junction-ambient	Max.	13 (*)	35	$^\circ C/W$

(*) Mounted on aluminum substrate



PIN FUNCTIONS (refer to the block diagram)

MW.15	PowerSO	Name	Function
1;15	2;19	Sense A; Sense B	Between this pin and ground is connected the sense resistor to control the current of the load.
2;3	4;5	Out 1; Out 2	Outputs of the Bridge A; the current that flows through the load connected between these two pins is monitored at pin 1.
4	6	V _S	Supply Voltage for the Power Output Stages. A non-inductive 100nF capacitor must be connected between this pin and ground.
5;7	7;9	Input 1; Input 2	TTL Compatible Inputs of the Bridge A.
6;11	8;14	Enable A; Enable B	TTL Compatible Enable Input: the L state disables the bridge A (enable A) and/or the bridge B (enable B).
8	1,10,11,20	GND	Ground.
9	12	V _{SS}	Supply Voltage for the Logic Blocks. A 100nF capacitor must be connected between this pin and ground.
10; 12	13;15	Input 3; Input 4	TTL Compatible Inputs of the Bridge B.
13; 14	16;17	Out 3; Out 4	Outputs of the Bridge B. The current that flows through the load connected between these two pins is monitored at pin 15.
–	3;18	N.C.	Not Connected

ELECTRICAL CHARACTERISTICS (V_S = 42V; V_{SS} = 5V, T_j = 25°C; unless otherwise specified)

Symbol	Parameter	Test Conditions	Min.	Typ.	Max.	Unit
V _S	Supply Voltage (pin 4)	Operative Condition	V _{IH} +2.5		46	V
V _{SS}	Logic Supply Voltage (pin 9)		4.5	5	7	V
I _S	Quiescent Supply Current (pin 4)	V _{en} = H; I _L = 0 V _i = L V _i = H		13 50	22 70	mA mA
		V _{en} = L V _i = X			4	mA
I _{SS}	Quiescent Current from V _{SS} (pin 9)	V _{en} = H; I _L = 0 V _i = L V _i = H		24 7	36 12	mA mA
		V _{en} = L V _i = X			6	mA
V _{iL}	Input Low Voltage (pins 5, 7, 10, 12)		-0.3		1.5	V
V _{iH}	Input High Voltage (pins 5, 7, 10, 12)		2.3		V _{SS}	V
I _{iL}	Low Voltage Input Current (pins 5, 7, 10, 12)	V _i = L			-10	μA
I _{iH}	High Voltage Input Current (pins 5, 7, 10, 12)	V _i = H ≤ V _{SS} - 0.6V		30	100	μA
V _{en} = L	Enable Low Voltage (pins 6, 11)		-0.3		1.5	V
V _{en} = H	Enable High Voltage (pins 6, 11)		2.3		V _{SS}	V
I _{en} = L	Low Voltage Enable Current (pins 6, 11)	V _{en} = L			-10	μA
I _{en} = H	High Voltage Enable Current (pins 6, 11)	V _{en} = H ≤ V _{SS} - 0.6V		30	100	μA
V _{CEsat} (H)	Source Saturation Voltage	I _L = 1A I _L = 2A	0.95	1.35 2	1.7 2.7	V V
V _{CEsat} (L)	Sink Saturation Voltage	I _L = 1A (5) I _L = 2A (5)	0.85	1.2 1.7	1.6 2.3	V V
V _{CEsat}	Total Drop	I _L = 1A (5) I _L = 2A (5)	1.80		3.2 4.9	V V
V _{sens}	Sensing Voltage (pins 1, 15)		-1 (1)		2	V

LM393, LM393E, LM293, LM2903, LM2903E, LM2903V, NCV2903



ON Semiconductor®

www.onsemi.com

Low Offset Voltage Dual Comparators

The LM393 series are dual independent precision voltage comparators capable of single or split supply operation. These devices are designed to permit a common mode range-to-ground level with single supply operation. Input offset voltage specifications as low as 2.0 mV make this device an excellent selection for many applications in consumer, automotive, and industrial electronics.

Features

- Wide Single-Supply Range: 2.0 Vdc to 36 Vdc
- Split-Supply Range: ± 1.0 Vdc to ± 18 Vdc
- Very Low Current Drain Independent of Supply Voltage: 0.4 mA
- Low Input Bias Current: 25 nA
- Low Input Offset Current: 5.0 nA
- Low Input Offset Voltage: 5.0 mV (max) LM293/393
- Input Common Mode Range to Ground Level
- Differential Input Voltage Range Equal to Power Supply Voltage
- Output Voltage Compatible with DTL, ECL, TTL, MOS, and CMOS Logic Levels
- ESD Clamps on the Inputs Increase the Ruggedness of the Device without Affecting Performance
- NCV Prefix for Automotive and Other Applications Requiring Unique Site and Control Change Requirements; AEC-Q100 Qualified and PPAP Capable
- These Devices are Pb-Free, Halogen Free/BFR Free and are RoHS Compliant

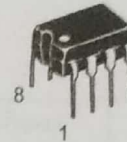

PDIP-8
N SUFFIX
CASE 626



SOIC-8
D SUFFIX
CASE 751



Micro8™
DM SUFFIX
CASE 846A

PIN CONNECTIONS

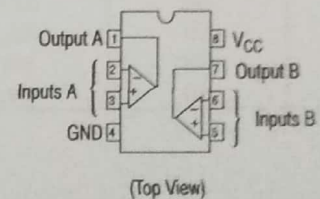

DEVICE MARKING AND ORDERING INFORMATION

See detailed marking information and ordering and shipping information on pages 6 and 7 of this data sheet.

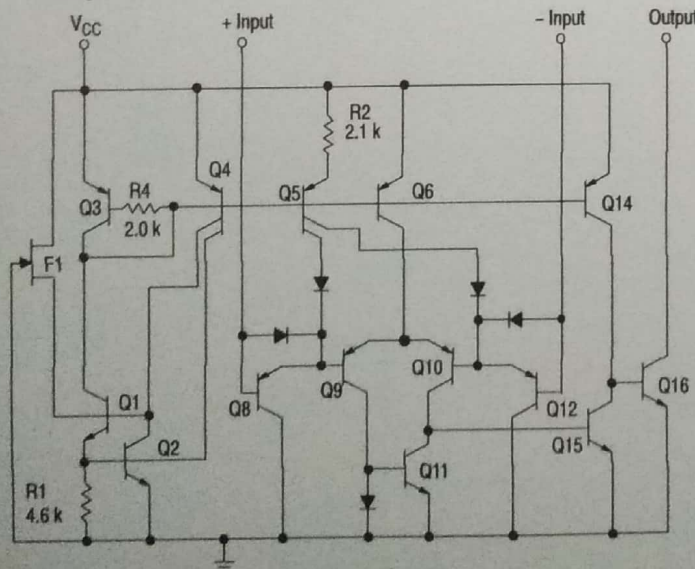

Figure 1. Representative Schematic Diagram
(Diagram shown is for 1 comparator)

LM393, LM393E, LM293, LM2903, LM2903E, LM2903V, NCV2903

MAXIMUM RATINGS

Rating	Symbol	Value	Unit
Power Supply Voltage	V_{CC}	+36 or ± 18	V
Input Differential Voltage	V_{IDR}	36	V
Input Common Mode Voltage Range	V_{ICR}	-0.3 to +36	V
Output Voltage	V_O	36	V
Output Short Circuit-to-Ground Output Sink Current (Note 1)	I_{SC} I_{Sink}	Continuous 20	mA
Power Dissipation @ $T_A = 25^\circ C$ Derate above $25^\circ C$	P_D $1/R_{\theta JA}$	570 5.7	mW mW/ $^\circ C$
Operating Ambient Temperature Range LM293 LM393, LM393E LM2903, LM2903E LM2903V, NCV2903 (Note 2)	T_A	-25 to +85 0 to +70 -40 to +105 -40 to +125	$^\circ C$
Maximum Operating Junction Temperature LM393, LM393E, LM2903, LM2903E, LM2903V LM293, NCV2903	$T_{J(max)}$	150 150	$^\circ C$
Storage Temperature Range	T_{stg}	-65 to +150	$^\circ C$

Stresses exceeding those listed in the Maximum Ratings table may damage the device. If any of these limits are exceeded, device functionality should not be assumed, damage may occur and reliability may be affected.

1. The maximum output current may be as high as 20 mA, independent of the magnitude of V_{CC} , output short circuits to V_{CC} can cause excessive heating and eventual destruction.
2. NCV2903 is qualified for automotive use.

ESD RATINGS

Rating	HBM	MM	Unit
ESD Protection at any Pin (Human Body Model - HBM, Machine Model - MM)			
NCV2903 (Note 2)	2000	200	V
LM393E, LM2903E	1500	150	V
LM393DG/DR2G, LM2903DG/DR2G	250	100	V
All Other Devices	1500	150	V