

The Effect of Brand Images on Trust and the Impact on Loyalty of Hospital Patients in PKU Muhammadiyah Gamping Hospital

Lidya Daniati*

*Korespondensi Author: lidya.lid2email@gmail.com

Hospital Management of Study Program, Universitas Muhammadiyah Yogyakarta, Bantul, Indonesia.

INDEXING

Keywords:

Brand Image;

Trust;

Loyalty.

ABSTRACT

Background: Hospitals can survive in the health industry, one of which has a strong and distinguishing brand image. There is a willingness to trust the brand with all the risks and expectations that provide positive results for consumers, to form and maintain trust that has an impact on gaining loyalty in the market today. **Methods:** This study is an observational quantitative study in cross-sectional analytic studies. The number of samples was 150 hospital patients. **Results and Discussion:** The results of SEM analysis, brand image has a positive and significant effect on trust and loyalty with $p = 0.000 < 0.05$ and $p = 0.033 < 0.05$, while trust does not affect loyalty ($p \text{ value} = 0.279 > 0.05$) in hospitalized patients at PKU Muhammadiyah Gamping Hospital. **Conclusions and Suggestions:** Trust cannot directly influence loyalty without the hospital brand image that is considered positive by the patient.

Kata kunci:

Citra Merek;

Kepercayaan;

Loyalitas.

Latar Belakang: Rumah Sakit dapat bertahan dalam bidang industri kesehatan, salah satunya dengan memiliki citra merek yang kuat dan bersifat membedakan. Adanya kemauan mempercayai merek dengan segala risikonya dan harapan yang memberikan hasil positif bagi konsumen, untuk terbentuk dan terpelihara kepercayaan yang berdampak memperoleh loyalitas dalam pasar saat ini. **Metode:** Penelitian ini adalah kuantitatif observasional pada studi analitik *cross-sectional*. Jumlah sampel sebanyak 150 pasien rawat inap. **Hasil dan Pembahasan:** Hasil analisis SEM yaitu citra merek berpengaruh positif dan signifikan terhadap kepercayaan dan loyalitas dengan nilai $p = 0.000 < 0.05$ dan $p = 0.033 < 0.05$, sedangkan kepercayaan tidak berpengaruh terhadap loyalitas (nilai $p = 0.279 > 0.05$) pada pasien rawat inap di RS PKU Muhammadiyah Gamping. **Kesimpulan dan Saran:** Kepercayaan tidak dapat secara langsung berpengaruh terhadap loyalitas tanpa adanya citra merek Rumah Sakit yang dinilai positif oleh pasien.

© 2018 JMMR. All rights reserved

Article history: received 5 Sept 2018; revised 7 Sept 2018; accepted 8 Sept 2018

INTRODUCTION

Hospital is a type of health services industry, its management objectives are to produce products or services in the form of health services that can meet consumer needs from various aspects. Various efforts have been made so that the Hospital can survive in the health industry, one of which is by having a strong brand.¹

Brands according to the American Marketing Association are names, terms, signs, symbols or designs, or a combination of them, which are intended to identify goods or services from a seller or group of sellers and distinguish them from the goods and services of its competitors. Consumers make the final decision about brand choice by processing information.² Modern marketing is based on creating differentiating brands that

can strengthen the brand image of the company. Brand image is a representation of the overall perception of the brand that is formed from information and past experience of the brand. The image of the brand relates to the attitude, namely in the form of beliefs and preferences for a brand. Consumers who have a positive image of a brand, will be more likely to make a purchase.³

In developing a more accurate strategy, the company must know the position of its competitors and a large estimate of the company's current market share or in the future to get loyal customers.⁴ Forming a trust and loyalty is obtained from several things, one of which is that consumers in the use of products or brands have good and positive experiences, so that consumers use a product or

brand together repeatedly because they think that the product or brand does not disappoint.⁵

According to Lau and Lee (1999), the person-to-person relationship is built with trust. Trust in the brand is the willingness to trust the brand with all the risks, and the hope that gives positive results for consumers. Marketers must focus on the relationship between brands and consumers, in order to form and maintain trust that has an impact on gaining loyalty in the market today.⁶

Based on Alhaddad's research (2015), about quality, brand image and brand trust that effect brand loyalty. The results showed that brand image has a positive and significant effect on brand trust and brand loyalty. The company's marketing manager must focus more on increasing brand loyalty from various dimensions of quality, brand image and brand trust.⁷

Hospitals that have strong brand image tend to more easily meet their needs and desires in accordance with customer perceptions, and can easily become the top position in the customer's mind.⁸ Hospital brand image is formed from medical, care, equipment, x-ray, laboratory, nutrition, and reputation attributes.⁹

One of the health service places in Yogyakarta is PKU Muhammadiyah Gamping Hospital. Islamic religious background and length of experience in the health industry is one of the consumers interests. This hospital was developed from PKU Muhammadiyah Yogyakarta Hospital, opened on February 15, 2009 and received an operational permit on June 16, 2010. This hospital still needs a lot of development because the age of this hospital itself is still relatively young.

Most people choose the PKU Muhammadiyah Gamping Hospital brand as the main destination for treatment because it is close to home, this hospital is a routine control place for patients, and there are doctors who are liked by patients. There are people who think that this hospital is for the service of medicine, nutrition, nurses, and doctors as well as its facilities to be hospitalized still losing to hospitals that are not of Islamic backgrounds in the Yogyakarta area.

PKU Muhammadiyah Gamping Hospital as a hospital with an Islamic background, really needs to strengthen and improve management, one of them in terms of quality with accreditation and fulfillment of various rules made by the government with good governance, so as to create a good brand image, trust and loyalty of all patients regardless of background. An increase in the number of patients can reflect the ability of the Hospital's brand image

in giving confidence to patients and also an option for patients to commit to come back.

Based on the above problems, it takes studies and research conducted to determine the effect of brand image on trust and impact on loyalty so that hospital patients at PKU Muhammadiyah Gamping Hospital as loyal consumers, consider the Hospital brand image is not disappointing and committed to using a product from a brand that same repeatedly, even though there are many other hospitals.

RESEARCH METHOD

This research is quantitative with cross sectional research design. The population of this study were patients who were hospitalized at PKU Muhammadiyah Gamping Hospital. The sample of this study were 150 people with the sampling technique which was purposive sampling. Analysis with Structural Equation Modeling (SEM).

RESULT AND DISCUSSION

1. Result

a. Description of Respondents

The condition description of the respondent gives an explanation of the description of the respondent regarding the analysis of the research variables. Descriptions of respondents obtained as described in Table 1.

Based on the table 1 shows that out of 150 research respondents, the majority of respondents with male gender as many as 89 people (59.3%) and with female gender as many as 61 people (40.7%). Respondents with the highest age were >50 years, namely 73 people (48.7%) and the majority of respondents education was High School as many as 70 people (46.7%).

Table 1. Description of Characteristics of Respondents

| No | Characteristics of Respondents | Frequency | Percentage (%) |
|----------|--------------------------------|-----------|----------------|
| 1 | Gender | | |
| | a. Man | 89 | 59,3 |
| | b. Woman | 61 | 40,7 |
| 2 | Age | | |
| | a. < 30 years | 36 | 24,0 |
| | b. 31 – 40 years | 12 | 8,0 |
| | c. 41 – 50 years | 29 | 19,3 |
| | d. > 50 years | 73 | 48,7 |
| 3 | Education | | |
| | a. Elementary School | 37 | 24,7 |
| | b. Middle School | 22 | 14,7 |
| | c. High School | 70 | 46,7 |
| | d. Diploma | 3 | 2,0 |
| | e. Bachelor | 8 | 5,3 |
| | f. Magister/ Master | 4 | 2,7 |
| | g. Does not work | 6 | 4,0 |
| | Total | 150 | 100,0 |

Source: Primary Data processed 2018

b. Descriptive Research Variables

1) Brand Image (X1)

Frequency distribution for brand image variables can be seen in the following Table 2:

Table 2. Brand Image Frequency Distribution Results (X1)

| Category | Interval | Amount (f) | Percentage (%) |
|--------------|---------------|------------|----------------|
| Good | 29,33 – 40,00 | 141 | 94,0 |
| Enough | 18,67 – 29,33 | 9 | 6,0 |
| Less | 8,00 – 18,67 | 0 | 0 |
| Total | | 150 | 100 |

Source: Primary Data processed 2018

Of the 150 respondents, the brand image in PKU Muhammadiyah Gamping Hospital was mostly in the good category of 141 respondents (94.0%) and enough categories as many as 9 respondents (6.0%). These results can be concluded that the brand image in PKU Muhammadiyah Gamping is good.

2) Trust (X2)

Frequency distribution for trust variables can be seen in Table 3 below:

Tabel 3. Trust Frequency Distribution Results (X2)

| Category | Interval | Amount (f) | Percentage (%) |
|--------------|---------------|------------|----------------|
| Good | 36,67 – 50,00 | 146 | 97,31 |
| Enough | 23,33 – 36,67 | 4 | 2,7 |
| Less | 10,00 – 23,33 | 0 | 0 |
| Total | | 150 | 100 |

Source: Primary Data processed 2018

Of the 150 respondents, trust in PKU Muhammadiyah Gamping Hospital was mostly in the good category as many as 146 respondents (97.31%), enough categories were 4 respondents (2.7%). These results can be concluded that the trust in PKU Muhammadiyah Gamping is good.

3) Loyalty (Y)

Frequency distribution for loyalty variables can be seen in Table 4 below:

Tabel 4. Loyalty Frequency Distribution Results (Y)

| Category | Interval | Amount (f) | Percentage (%) |
|--------------|---------------|------------|----------------|
| Good | 44,00 – 60,00 | 119 | 79,3 |
| Enough | 28,00 – 44,00 | 29 | 19,3 |
| Less | 12,00 – 28,00 | 2 | 1,3 |
| Total | | 150 | 100 |

Source: Primary Data processed 2018

Of the 150 respondents, loyalty was mostly in the good category as many as 119 respondents (79.3%), enough categories were 29 respondents (19.3%), and in the less category were 2 respondents (1.3%). These results can be concluded that loyalty at PKU Muhammadiyah Gamping Hospital is good.

c. Data Analysis Results

1) Goodness of Fit Model I (Initial Model)

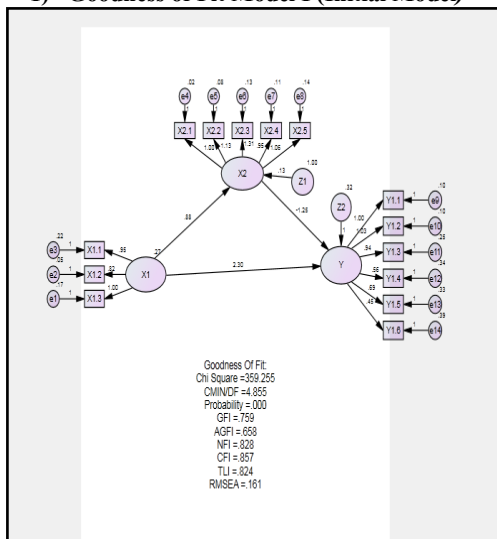

Figure 1. Results of Initial Model Analysis

Theoretical model in the conceptual framework of research is said to be fit if supported by empirical data. The test results of goodness of fit overall model are used to determine whether the hypothetical model is supported by empirical data, the computational results with the AMOS program for the SEM model are generated goodness of fit indices as given in Table 1 below:

Tabel 5. Goodness of Fit Index Initial Model

| Goodness of Fit | Analysis Results | Cut-off Value | Info |
|-----------------------|------------------|----------------|----------|
| χ^2 (Chi-Square) | 359.255 | Small expected | Less |
| Probability | 0,000 | $\geq 0,05$ | Less |
| CMIND/DF | 4.855 | ≤ 2 | Less |
| GFI | 0,759 | $\geq 0,90$ | Less |
| AGFI | 0,658 | $\geq 0,90$ | Less |
| NFI | 0,828 | $\geq 0,95$ | Marginal |
| CFI | 0,857 | $\geq 0,90$ | Marginal |
| TLI | 0,824 | $\geq 0,95$ | Marginal |
| RMSEA | 0,161 | $\leq 0,08$ | Less |

Source: Primary Data processed 2018

The results of the Goodness of Fit obtained a Chi-Square value of 359.255 with a probability of 0.000 indicating the model is not fit because the value is not in accordance with the recommended value. Other fit criteria are GFI, TLI, CFI, NFI, and RMSEA to conclude the overall goodness of fit model, the CMIN/DF value of 4,855 shows the fit model is less than the recommended value, GFI value is 0.759, NFI is 0.828, TLI is 0.824 and CFI of 0.857 indicates the model is not fit because it is less than the recommended value. The RMSEA value of 0.161 also indicates that the fit model does not match the recommended value.

2) Hypothesis Testing (Initial Model)

Tabel 6. Hypothesis testing

| Hypothesis | Estimate | C,R | P | Hypothesis |
|------------------------|----------|--------|-------|------------|
| Trust <- Brand Image | 0,876 | 11,909 | 0,000 | Accepted |
| Loyalty <- Brand Image | 2,295 | 2,063 | 0,039 | Accepted |
| Loyalty <- Trust | -1,247 | -1.052 | 0,293 | Rejected |

Source: Primary Data processed 2018

The results of hypothesis testing show results that have not been significant and the results of testing the overall goodness of fit concluded that the model cannot be said to be fit, therefore modification of model II or final model is modified.

3) Final Model Goodness of Fit Test

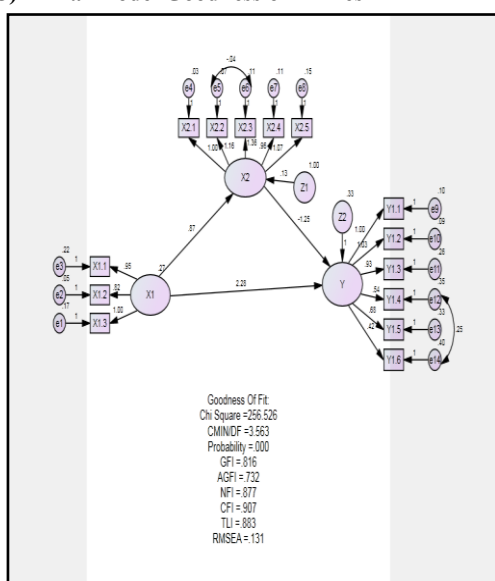

Figure 2. Final Model Analysis Results

Theoretical model in the conceptual framework of research is said to be fit if supported by empirical data. The results of testing the goodness of fit overall model are used to determine whether the hypothesis model is supported by empirical data. The computation results with the AMOS program for the SEM model produced goodness of fit indices as given in Table 7 below:

Table 7. Goodness of Fit Index Model

| Goodness of Fit | Analysis Results | Cut-off Value | Info |
|-----------------------|------------------|----------------|----------|
| χ^2 (Chi-Square) | 256,526 | Small expected | Less |
| Probability | 0,000 | $\geq 0,05$ | Less |
| CMIND/DF | 3,563 | ≤ 2 | Less |
| GFI | 0,816 | $\geq 0,90$ | Marginal |
| AGFI | 0,732 | $\geq 0,90$ | Less |
| NFI | 0,877 | $\geq 0,95$ | Marginal |
| CFI | 0,907 | $\geq 0,90$ | Good/Fit |
| TLI | 0,883 | $\geq 0,95$ | Marginal |
| RMSEA | 0,131 | $\leq 0,08$ | Less |

Source: Primary Data processed 2018

The results of the Goodness of Fit obtained a Chi-Square value of 256.526 with a probability of 0.000 indicating the model is not

fit because the value is not in accordance with the recommended value. However, it is necessary to look at other fit criteria, namely GFI, TLI, CFI, NFI, and RMSEA to conclude the goodness of fit overall model. CMIN / DF value of 3.563 shows the fit model according to the recommended value, GFI value of 0.816, NFI of 0.877, TLI of 0.883 and CFI of 0.907 indicating the model is fit because it is more than the recommended value. The results of testing the goodness of fit as a whole can be concluded that the hypothetical model is supported by empirical data, or the model can be said to be fit.

4) Hypothesis Testing (Final Model)

The research hypothesis is the relationship between variables tested by looking at the partial test of each variable. To accept the alternative hypothesis that there is an influence of the independent variable on the dependent variable can be assessed from the value of C, R. The alternative hypothesis is accepted if the value of C, R ≥ 2 or $P \leq 0.05$, a summary of the results of testing the research hypothesis can be seen as follows.

Table 8. Hypothesis testing

| Hypothesis | Estimate | C,R | P | Hypothesis |
|------------------------|----------|--------|-------|------------|
| Trust <- Brand Image | 0,866 | 11,869 | 0,000 | Accepted |
| Loyalty <- Brand Image | 2,284 | 2,127 | 0,033 | Accepted |
| Loyalty <- Trust | -1,249 | -1,083 | 0,279 | Rejected |

Source: Primary Data processed 2018

Explanation of the results of the t test (C, R) to determine the effect of each variable is as follows:

a) Brand image effect the trust of hospital patients at PKU Muhammadiyah Gamping Hospital.

The results of the t test statistic (C,R) in table 8 to determine the effect of brand image on trust obtained C,R value of 11.869 and t table 1.660 (df= 100, p= 0.05) with a significance value of 0.000, because C,R > t table (11,869 > 1,660), and the significance value is less than 0,000 (p<0,05), and the coefficient has a positive

value then the hypothesis which states that “Brand image has a positive and significant effect on trust in hospitalized patients at PKU Muhammadiyah Gamping Hospital” was accepted.

b) Brand image effect the loyalty of hospital patients at PKU Muhammadiyah Gamping Hospital.

The results of the t test statistic (C,R) in table 8 to determine the effect of brand image on loyalty obtained the value of C,R of 2,284 and t table 1,660 (df= 100, p= 0,05) with a significance value of 0,033, because $C,R > t \text{ table}$ ($2,284 > 1,660$), and the significance value is less than 0,033 ($p < 0,05$), and the coefficient has a positive value then the hypothesis which states that “Brand image has a positive and significant effect on loyalty in hospitalized patients at PKU Muhammadiyah Gamping Hospital” was accepted.

c) Trust affect the loyalty of hospital patients at PKU Muhammadiyah Gamping Hospital.

The results of the t test statistics (C,R) in table 8 to determine the effect of trust on loyalty obtained the value of C,R of -1.294 and t table 1.660 (df= 100, p= 0.05) with a significance value of 0.279, because $C,R > t \text{ table}$ ($-1,249 > 1,660$), and the significance value is greater than 0,279 ($p < 0,05$), and the coefficient has a negative value then the hypothesis which states that “Trust has a positive and significant effect on loyalty in hospitalized patients at PKU Muhammadiyah Gamping Hospital” was rejected. The results of the analysis showed that "Trust does not affect loyalty to hospital patients at PKU Muhammadiyah Gamping Hospital."

2. Discussion

a. Brand image effect the trust of hospital patients at PKU Muhammadiyah Gamping Hospital.

Brand image effects the trust obtained significant value of $0.000 < 0.05$, the brand image has a positive and significant effect on trust of hospital patients at PKU Muhammadiyah Gamping Hospital. The results stated that there was a positive

and significant relationship which showed that the higher the brand image given to patients, the higher the level of trust in PKU Muhammadiyah Gamping Hospital.

The findings of the study are consistent with the research conducted by Alhaddad (2015) with the results of the study showing the hypothesis that supports the current research that brand image has a significant and positive effect on brand trust, indicated by the value of brand image ($\beta = 0.21$) and brand trust ($\beta = 0.19$).⁷ The company's marketing manager must focus more on increasing brand loyalty from various dimensions of quality, brand image and brand trust. Trust in brands is directly related to the quality of services provided by an organization so this can benefit the organization in retaining customers, gaining customer trust, financial performance and competitive advantage.

Brand image according to Keller (2008) is the perception of consumers about a brand that is in the minds of consumers.¹⁰ Positive images in consumer perceptions will reduce disappointment with poor health service experiences and help hospital management overcome negative images, for example in the case of bad experiences consumers need a lot of good experience to change the overall image.¹¹ Brand image (brand image) is influenced by components of the Hospital image, user or patient image (user brand) and the image of the product or service provided (product brand).¹²

Brand Image in PKU Muhammadiyah Gamping Hospital is considered as one of the very important dimensions of quality and is one of the main indicators of the standard of a health facility, especially as one of the hospitals that promotes optimal service Hospital Trust is an important element in health services. Patients assess their level of trust or distrust after using Hospital services and use this information to update their perception of the quality of services provided by health workers in the Hospital and based on the components of the brand image owned by the Hospital.

Based on the theory and the results of previous studies it can be concluded that brand image has a positive and significant effect on patient trust. The higher the brand image is given to patients, the higher the level of confidence of

hospital patients at PKU Muhammadiyah Gamping Hospital.

b. Brand image effect the loyalty of hospital patients at PKU Muhammadiyah Gamping Hospital.

Brand image has an effect on loyalty, obtained a significant value of $0.033 < 0.05$, the brand image has a positive and significant effect on loyalty of hospital patients at PKU Muhammadiyah Gamping Hospital. The results stated that there was a positive and significant relationship which showed that the higher the brand image given to patients, the higher the level of loyalty at PKU Muhammadiyah Gamping Hospital.

The study is in accordance with research conducted by Chao-Chan Wu (2011) with the results of research that supports the current research hypothesis that there is a direct and indirect influence between Hospital brand image and patient loyalty.¹² This shows that the Hospital's positive brand image not only increases patient loyalty directly, but also affects patient satisfaction which has an effect on the acceptance of service quality, thereby increasing the return of patients intensively to the hospital.

Another suitable study was conducted by Fatema et al. (2013), in his research which aims to determine the relationship between brand image and brand loyalty using SEM (Structured Equation Modeling) analysis with CFA (Confirmatory Factor Analysis). The results of this study are that there is a strong relationship between brand image and brand loyalty. Brand loyalty affects good behavior in a brand competition, consumers will have a strong influence on the purchase or continuous use of services for this brand.¹³

Brand loyalty is a deep commitment to repurchase products or services that are consistently preferred in the future by buying the same brand despite the situational influence and marketing efforts that can lead to transitional behavior. In consumer loyalty, repetitive action against the purchase of the brand is influenced by loyalty to the brand and the image provided by service providers, especially services in the health sector.^{14,15} BPJS and Non BPJS patients at PKU Muhammadiyah Hospital Gamping assess the quality of services provided by health workers based on the image

provided by the Hospital, if the image of the Hospital is able to provide satisfaction with the services received by patients, then patients will be increasingly loyal to the Hospital.

Based on the theory and results of previous studies it can be concluded that brand image has a positive and significant effect on loyalty. The higher the brand image given to patients, the higher the level of loyalty of hospital patients at PKU Muhammadiyah Gamping Hospital.

c. Trust effect the loyalty of hospital patients at PKU Muhammadiyah Gamping Hospital.

Trust does not affect loyalty obtained significant value of $0.279 > 0.05$, so that confidence does not affect loyalty of hospital patients at PKU Muhammadiyah Gamping Hospital. These results are in accordance with research conducted by and Sukmawati and Massie (2015) which also shows that there is no significant influence between trust in loyalty.¹⁶

Consumer trust in brands can only be obtained if marketers can create and maintain positive emotional relationships with consumers.¹⁷ Trust in the brand is the willingness to trust the brand with all the risks, and the hope that gives positive results for consumers. Marketers must focus on the relationship between brands and consumers, in order to form and maintain trust that has an impact on gaining loyalty in the market today.

Forming a trust and loyalty in PKU Muhammadiyah Gamping Hospital is obtained from several things, one of which is that consumers or patients in the use of health services have good and positive experiences, so that these patients use the same services repeatedly because they assume that these services are not disappointing.⁵ In developing a more accurate strategy, the Hospital must know the position of its competitors and the estimated large market share of the Hospital at present or in the future to get loyal patients.⁴

The results of the study illustrate that trust does not affect loyalty in hospitalized patients at PKU Muhammadiyah Gamping Hospital, trust cannot directly affect loyalty without the hospital's image being positively assessed by the patient. Nonetheless, a high level of patient trust must be maintained, because customers who believe in the

Hospital tend to inform their descendants and their families to use similar services in the future.

CONCLUSION

There is a positive and significant influence between brand image on trust and between brand image on loyalty in hospitalized patients at PKU Muhammadiyah Gamping Hospital. There is no effect between trust on loyalty in hospitalized patients at PKU Muhammadiyah Gamping Hospital. Trust cannot directly affect loyalty without the Hospital's image being positively assessed by the patient.

REFERENCES

- Rizqiani, A. (2013). Brand Equity Tadjuddin Chalid Hospital Makassar. *Indonesian Public Health Media Journal*, 9 (2), 88-94.
- Kotler, P., and Keller, K.L. (2008). *Marketing Management*. Thirteenth Edition. Volume I. Jakarta: Erlangga.
- Annisa, Mira. (2016). *Influence of Brand Image, Brand Trust, and Consumer Satisfaction on Brand Courier Loyalty*. Faculty of Economics. Yogyakarta State University.
- Pramono, A., and Rusdiansyah, A. (2007). *Pattern Analysis of the Use of Cellular Phone Prepaid Cards for Student Consumers with the Markov Chain Method*. ITS Technology Management Masters Study Program. Proceedings of VI National Technology Management Seminar Surabaya.
- Panjaitan, A.O.Y., Rofiaty, and Sudjatno. (2016). The Influence of Brand Experience on Brand Loyalty Through Mediation of Brand Satisfaction and Brand Trust (Studies in the Typical Culinary of Malang City). *Journal of Business and Management*, 3 (2), 141-161.
- Lau, G.T., dan Lee, S.H. (1999). Consumer's Trust in a Brand and the Link to Brand Loyalty. *Journal of Market Focused Management*, 4 (4), 341-370.
- Alhaddad, Abdullah. (2015). Perceived Quality, Brand Image, and Brand Trust as Determinants of Brand Loyalty, *Journal of Research in Business and Management*, 3 (4), 1-8.
- Nurulaini, Nunun. (2010). *Analysis of Brand Equity in Jakarta Islamic Hospital According to Perceptions of Outpatient Customers in Four Basic Services in 2010*. Faculty of Public Health. Jakarta Hospital Administration Study Master Program. University of Indonesia.
- Arifin, J., and Prasetya, H.A. (2006). *Computer Based Modern Hospital Management*. Jakarta: PT. Elex Media Komputindo.
- Keller, K.L. (2008). *Strategic Brand Management*. 3rd Edition. New Jersey: Prentice Hall.
- Sumaedi, S., Bakti, I.G.M, Astrini, N.J., dan Yarmen, M. (2014). *Public Transport Passengers' Behavioural Intentions Paratransit in Jabodetabek-Indonesia*. New York: Springer.
- Wu, Chao-Chan. (2011). The Impact of Hospital Brand Image on Service Quality, Patient Satisfaction, and Loyalty. *African Journal of Business Management*, 5 (12), 4873-4882.
- Fatema, M., Azad, K., dan Masum, A.K.M. (2013). Impact of Brand Image and Brand Loyalty in Measuring Brand Equity of Islami Bank Bangladesh Ltd. *Asian Business Review*, 2 (1), 42-46.
- Schiffman, L.G., dan Kanuk, L.L. (2004). *Customer Behavior*. 8th Edition. New York: Pearson Prentice Hall.
- Purbasari, D.M., and Purnamasari, D.L. (2016). Antecedents of Brand Attachment in Building Brand Relationships on Consumers (Trust, Satisfaction, and Commitment) to Loyalty. *National Seminar on Technological Innovation and Engineering Faculty of Engineering, University August 17, 1945 Cirebon*, 5 (1), 38-46.
- Sukmawati, I., dan Massie, James. (2015). The Effect of Service Quality Mediated by Customer Satisfaction and Trust toward Customer Loyalty in PT Air Manado. *EMBA Journal*, 3(3), 729-742.
- Fauzan, M. (2016). Effect of Indihome Brand Trust on Customer Loyalty in Bandung City. *E-Proceeding of Management*, 3 (2), 2414-2420.