

LAMPIRAN

1. OVER ALL SINGLE LINE KMJ UNIT 4

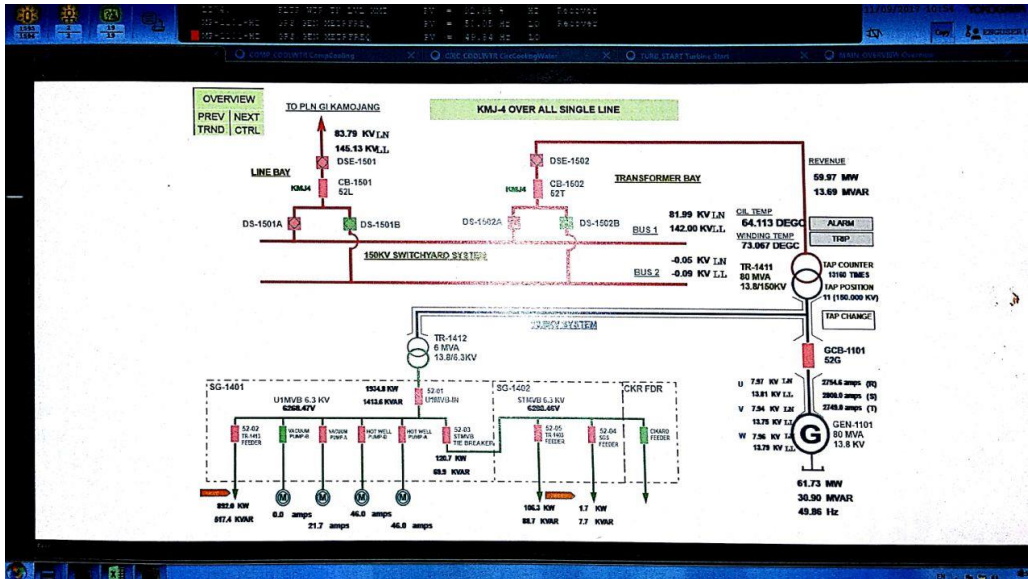

2. SINGLE LINE DIAGRAM 150Kv Switchyard

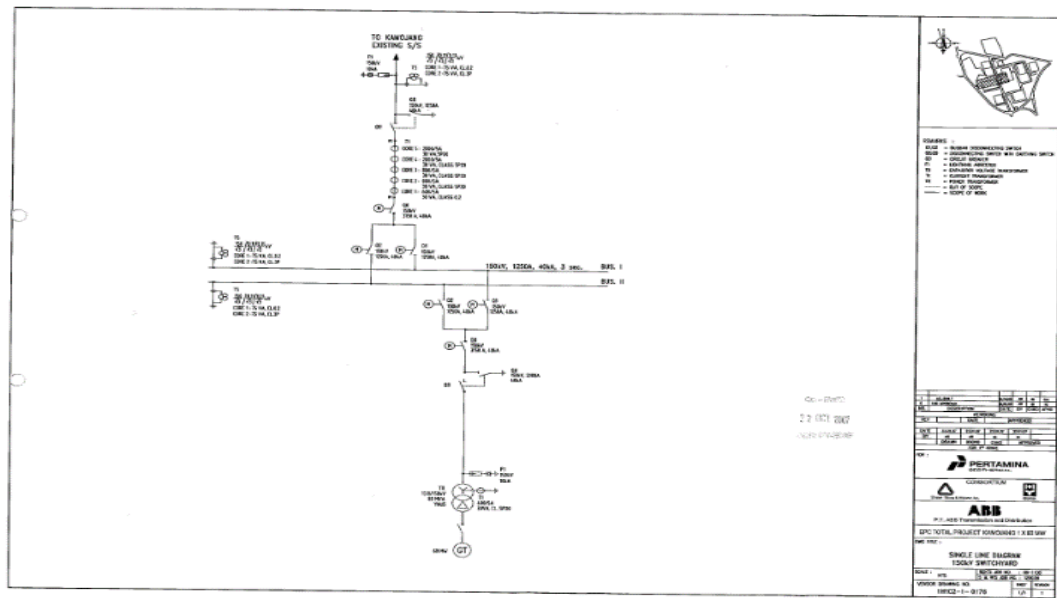

3. Zona Proteksi Rele Differensial (87B) Busbar

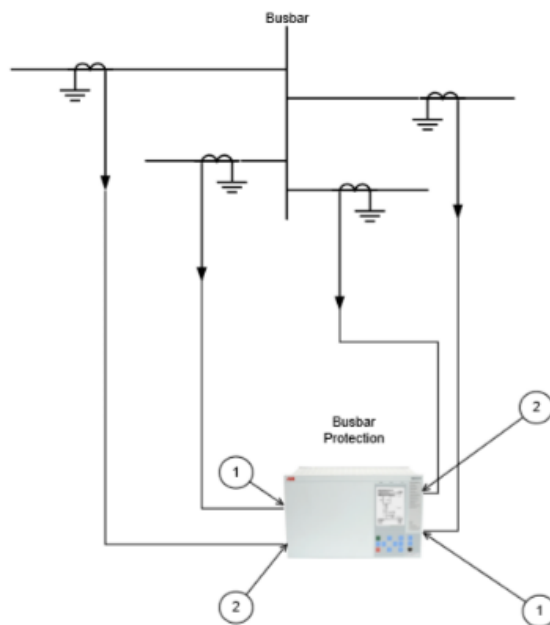
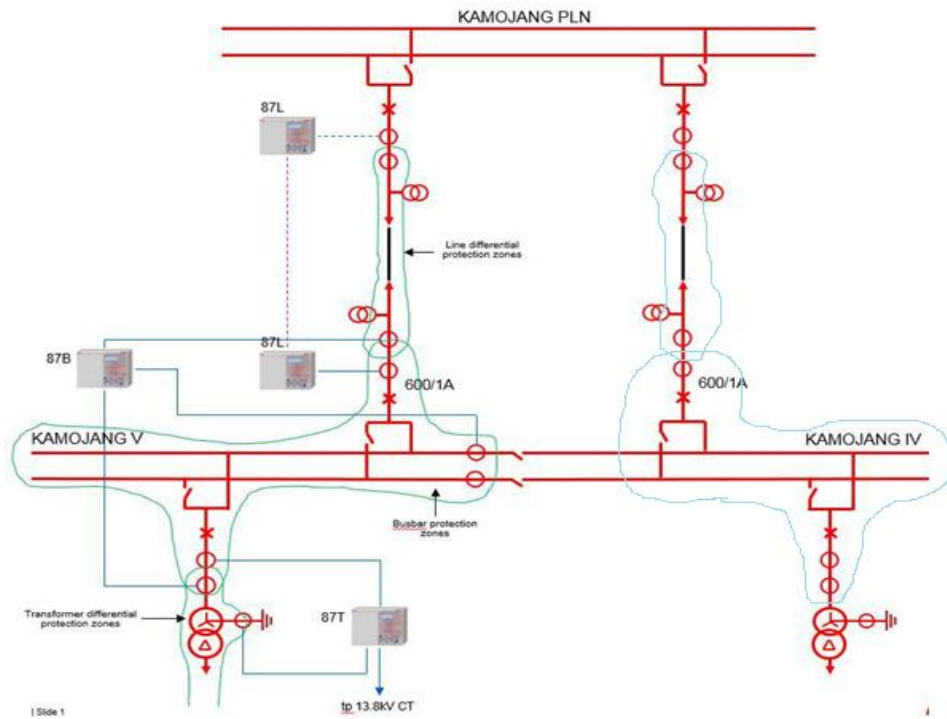

4. Simulasi *Differential Relé* pada Busbar menggunakan Software ETAP 12.6

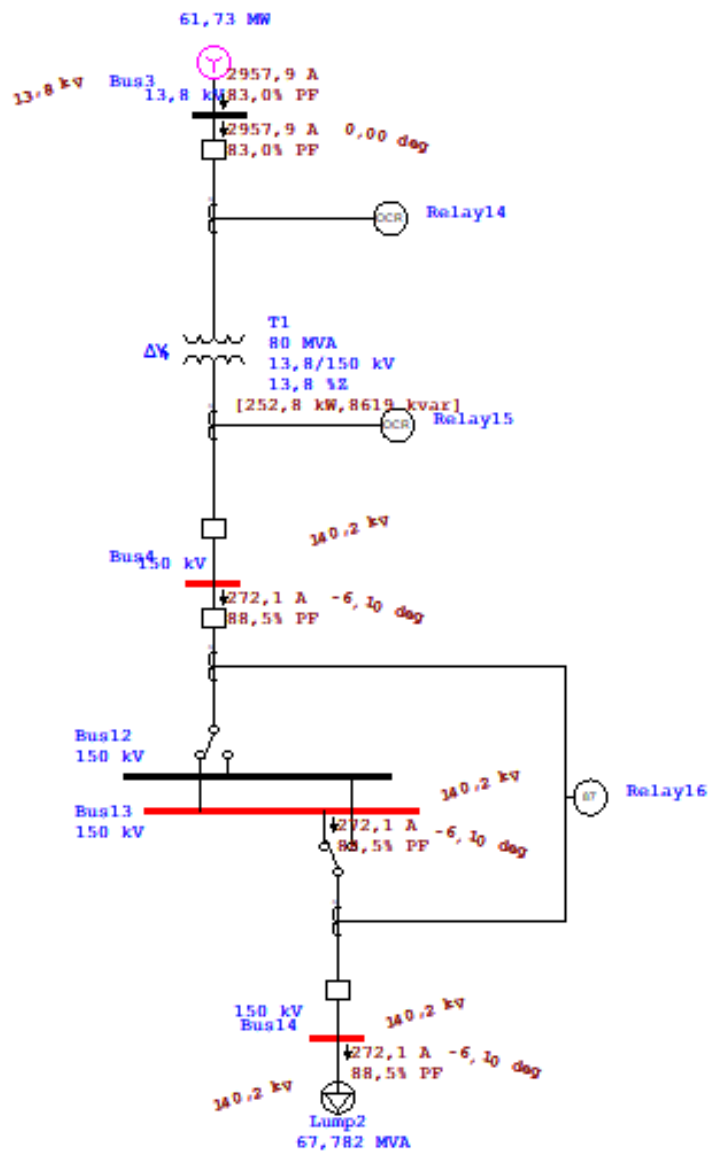

5. Simulasi short circuit di luar Zona Proteksi Differential Relé Busbar

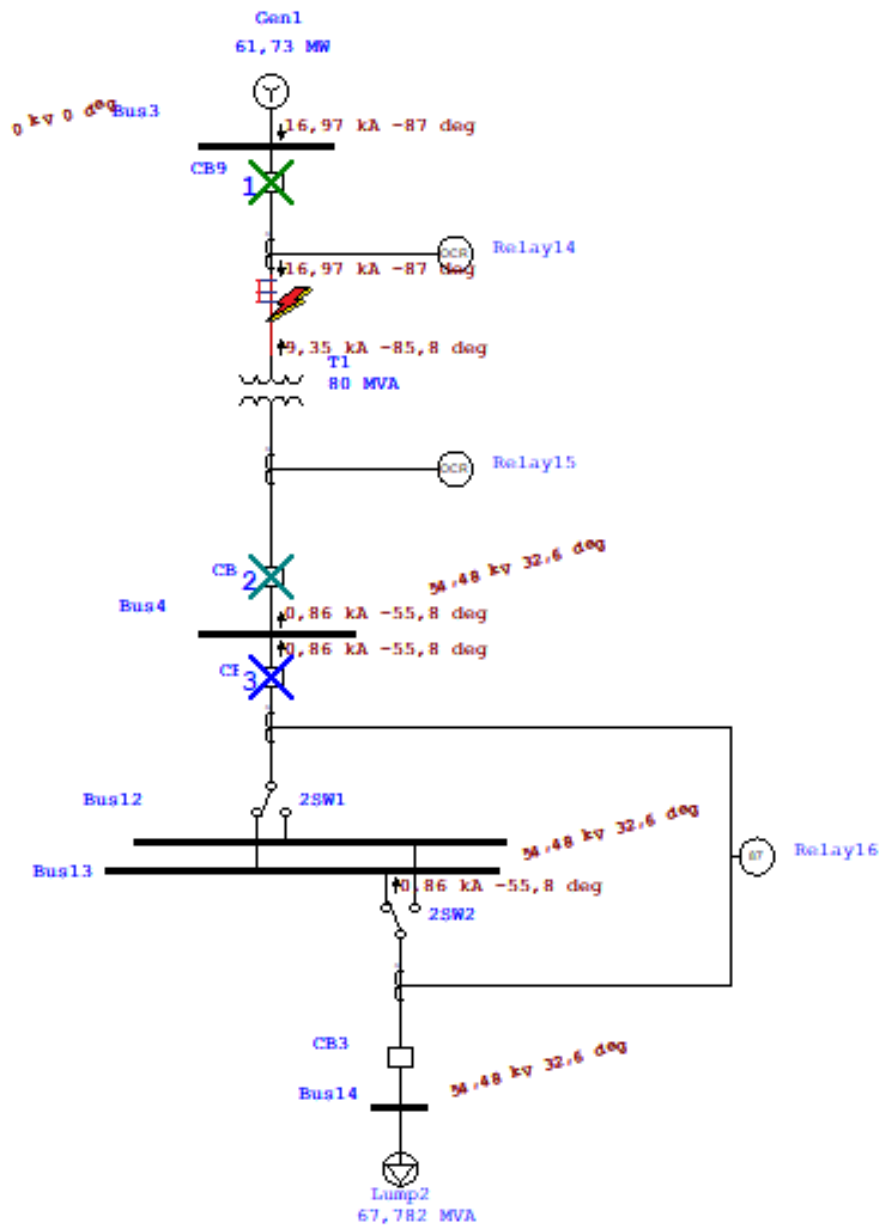

6. Simulasi short circuit di dalam Zona Proteksi Differential Relé

